

BUNN®

AutoPOD™

BREWER
My Café® AP

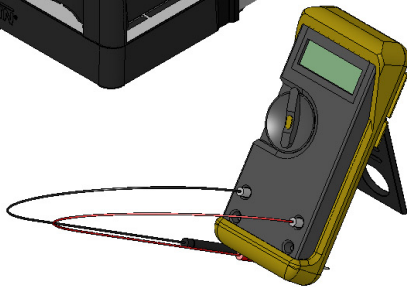

SERVICE & REPAIR MANUAL

BUNN-O-MATIC CORPORATION

POST OFFICE BOX 3227

SPRINGFIELD, ILLINOIS 62708-3227

PHONE: (217) 529-6601 FAX: (217) 529-6644

To ensure you have the latest revision of the Operating Manual, or to view the Illustrated Parts Catalog, Programming Manual, or Service Manual, please visit the Bunn-O-Matic website, at www.bunn.com. This is absolutely FREE, and the quickest way to obtain the latest catalog and manual updates. For Technical Service, contact Bunn-O-Matic Corporation at 1-800-286-6070.

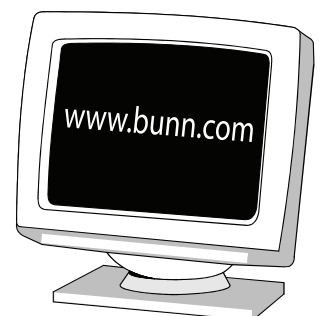

BUNN-O-MATIC COMMERCIAL PRODUCT WARRANTY

Bunn-O-Matic Corp. ("BUNN") warrants equipment manufactured by it as follows:

- 1) Airpots, thermal carafes, decanters, GPR servers, iced tea/coffee dispensers, MCP/MCA pod brewers thermal servers and ThermoFresh servers (mechanical and digital)- 1 year parts and 1 year labor.
- 2) All other equipment - 2 years parts and 1 year labor plus added warranties as specified below:
 - a) Electronic circuit and/or control boards - parts and labor for 3 years.
 - b) Compressors on refrigeration equipment - 5 years parts and 1 year labor.
 - c) Grinding burrs on coffee grinding equipment to grind coffee to meet original factory screen sieve analysis - parts and labor for 4 years or 40,000 pounds of coffee, whichever comes first.

These warranty periods run from the date of installation BUNN warrants that the equipment manufactured by it will be commercially free of defects in material and workmanship existing at the time of manufacture and appearing within the applicable warranty period. This warranty does not apply to any equipment, component or part that was not manufactured by BUNN or that, in BUNN's judgment, has been affected by misuse, neglect, alteration, improper installation or operation, improper maintenance or repair, non periodic cleaning and descaling, equipment failures related to poor water quality, damage or casualty. In addition, the warranty does not apply to replacement of items subject to normal use including but not limited to user replaceable parts such as seals and gaskets. This warranty is conditioned on the Buyer 1) giving BUNN prompt notice of any claim to be made under this warranty by telephone at (217) 529-6601 or by writing to Post Office Box 3227, Springfield, Illinois 62708-3227; 2) if requested by BUNN, shipping the defective equipment prepaid to an authorized BUNN service location; and 3) receiving prior authorization from BUNN that the defective equipment is under warranty.

THE FOREGOING WARRANTY IS EXCLUSIVE AND IS IN LIEU OF ANY OTHER WARRANTY, WRITTEN OR ORAL, EXPRESS OR IMPLIED, INCLUDING, BUT NOT LIMITED TO, ANY IMPLIED WARRANTY OF EITHER MERCHANTABILITY OR FITNESS FOR A PARTICULAR PURPOSE. The agents, dealers or employees of BUNN are not authorized to make modifications to this warranty or to make additional warranties that are binding on BUNN. Accordingly, statements by such individuals, whether oral or written, do not constitute warranties and should not be relied upon.

If BUNN determines in its sole discretion that the equipment does not conform to the warranty, BUNN, at its exclusive option while the equipment is under warranty, shall either 1) provide at no charge replacement parts and/or labor (during the applicable parts and labor warranty periods specified above) to repair the defective components, provided that this repair is done by a BUNN Authorized Service Representative; or 2) shall replace the equipment or refund the purchase price for the equipment.

THE BUYER'S REMEDY AGAINST BUNN FOR THE BREACH OF ANY OBLIGATION ARISING OUT OF THE SALE OF THIS EQUIPMENT, WHETHER DERIVED FROM WARRANTY OR OTHERWISE, SHALL BE LIMITED, AT BUNN'S SOLE OPTION AS SPECIFIED HEREIN, TO REPAIR, REPLACEMENT OR REFUND.

In no event shall BUNN be liable for any other damage or loss, including, but not limited to, lost profits, lost sales, loss of use of equipment, claims of Buyer's customers, cost of capital, cost of down time, cost of substitute equipment, facilities or services, or any other special, incidental or consequential damages.

392, AutoPOD, AXIOM, BrewLOGIC, BrewMETER, Brew Better Not Bitter, BrewWISE, BrewWIZARD, BUNN Espresso, BUNN Family Gourmet, BUNN Gourmet, BUNN Pour-O-Matic, BUNN, BUNN with the stylized red line, BUNNlink, Bunn-OMatic, Bunn-O-Matic, BUNNserve, BUNNSERVE with the stylized wrench design, Cool Froth, DBC, Dr. Brew stylized Dr. design, Dual, Easy Pour, EasyClear, EasyGard, FlavorGard, Gourmet Ice, Gourmet Juice, High Intensity, iMIX, Infusion Series, Intellisteam, My Café, Phase Brew, PowerLogic, Quality Beverage Equipment Worldwide, Respect Earth, Respect Earth with the stylized leaf and coffee cherry design, Safety-Fresh, savemycoffee.com, Scale-Pro, Silver Series, Single, Smart Funnel, Smart Hopper, SmartWAVE, Soft Heat, SplashGard, The Mark of Quality in Beverage Equipment Worldwide, ThermoFresh, Titan, trifecta, Velocity Brew, A Partner You Can Count On, Air Brew, Air Infusion, Beverage Bar Creator, Beverage Profit Calculator, Brew better, not bitter., BUNNSource, Coffee At Its Best, Cyclonic Heating System, Daypart, Digital Brewer Control, Nothing Brews Like a BUNN, Pouring Profits, Signature Series, Tea At Its Best, The Horizontal Red Line, Ultra are either trademarks or registered trademarks of Bunn-O-Matic Corporation.

CONTENTS

Warranty.....	2
Contents	3
Troubleshooting	4
Diagnostics.....	9
Service	10
Schematics	25

TROUBLESHOOTING

A troubleshooting guide is provided to suggest probable causes and remedies for the most likely problems encountered. If the problem remains after exhausting the troubleshooting steps, contact the Bunn-O-Matic Technical Service Department.

- Inspection, testing, and repair of electrical equipment should be performed only by qualified service personnel.
- All electronic components have ac line voltage and some have low voltage dc potential on their terminals. Shorting of terminals or the application of external voltages may result in board failure.
- Intermittent operation of electronic circuit boards is unlikely. Board failure will normally be permanent. If an intermittent condition is encountered, the cause will likely be a switch contact or a loose connection at a terminal or crimp.
- Solenoid removal requires interrupting the water supply to the valve. Damage may result if solenoids are energized for more than ten minutes without a supply of water.
- The use of two wrenches is recommended whenever plumbing fittings are tightened or loosened. This will help to avoid twists and kinks in the tubing.
- Make certain that all plumbing connections are sealed and electrical connections tight and isolated.
- This brewer is heated at all times. Keep away from combustibles.

- WARNING**
- **Exercise extreme caution when servicing electrical equipment.**
 - **Unplug the brewer when servicing, except when electrical tests are specified.**
 - **Follow recommended service procedures.**
 - **Replace all protective shields or safety notices.**

TROUBLESHOOTING (cont.)

REFILL CIRCUIT

PROBLEM	PROBABLE CAUSE	REMEDY
"FILL TIME TOO LONG"	<ol style="list-style-type: none">1. Water shut off2. Debris blocking inlet.3. Water pressure below 20psi.4. No voltage to solenoid valve.5. Solenoid valve defective.	<p>Make sure water is ON.</p> <p>Clean out debris.</p> <p>Contact plumber.</p> <p>Check wiring/CBA.</p> <p>Replace solenoid valve.</p>
Refill does not shut off Power "ON"	<ol style="list-style-type: none">1. Lime build up on probe.2. Water Level Sensing System	<p>Remove Level Probe and check for lime deposits on tip. Clean and reinstall.</p> <p>Check wiring for open connection.</p>
Refill does not shut off Power "OFF"	<ol style="list-style-type: none">1. Refill valve stuck open.	<p>Clean or replace valve as needed.</p>

TROUBLESHOOTING (cont.)

HEATING CIRCUIT

PROBLEM	PROBABLE CAUSE	REMEDY
"BREW TEMP SENSOR OUT OF RANGE"	1. CBA senses open or short circuit.	Check wiring.
"BREW TANK HEATING TOO LONG"	1. Limit Thermostat or TCO open.	Replace.
	2. Tank heater defective.	Replace heater.
	3. No voltage to tank heater.	Check wiring. Replace CBA.
Spitting or excessive steaming	1. Lime build up on temperature probe, tank or tank heater	Check/replace
	2. Temperature Probe	Check/replace
	3. Control Board	Check/replace
Brewer is making unusual noises	1. Plumbing lines	Plumbing lines should not rest on the counter top.
	2. Water supply	The brewer must be connected to a cold water supply.
	3. Lime build up	Remove the tank lid and clean inside of tank with a deliming agent, if necessary.

**TROUBLESHOOTING (cont.)
BREWING CIRCUIT**

PROBLEM	PROBABLE CAUSE	REMEDY
Brew cycle will not start	<ol style="list-style-type: none"> 1. Displays error message 2. No power or incorrect voltage to the brewer. 3. Low water temperature (Brew lockout is enabled) 4. Membrane Switch 	<p>Brewer has shut down due to malfunction.</p> <p>Check for correct voltage at the outlet.</p> <p>Allow brewer to heat until ready, or disable the brew lockout feature.</p> <p>Check/replace.</p>
Consistently low beverage level in the dispenser or beverage overflows dispenser.	<ol style="list-style-type: none"> 1. Brew volume 	<p>Adjust Brew volume. NOTE: Volume adjustments must be made with sprayhead installed.</p>
Brew volume incorrect or inconsistent.	<ol style="list-style-type: none"> 1. Brew volume 2. Brew volume not calibrated. 3. Flow meter. 4. "AIR TIME" set too low. 	<p>Adjust Brew volume. NOTE: Volume adjustments must be made with sprayhead installed.</p> <p>Perform calibration procedure.</p> <p>Check/replace.</p> <p>Adjust.</p>
<p>"NO FLOW COUNTS DURING BREW" No pulses from flow meter.</p>	<ol style="list-style-type: none"> 1. Water shut off. 2. Flow meter/inlet blocked/limed up. 3. Flow meter defective. 4. No voltage to solenoid valve. 5. Solenoid valve defective. 	<p>Make sure water is ON.</p> <p>Check/replace.</p> <p>Check/replace.</p> <p>Check wiring/CBA.</p> <p>Replace solenoid valve.</p>

TROUBLESHOOTING (cont.)

BREWING CIRCUIT (cont.)

PROBLEM

"WATER PUMP FAULT CHECK WATER PUMP"

Water does not drop below level probe for 90 seconds during brew cycle.

PROBABLE CAUSE

1. Sprayhead blockage.
2. Tubing between tank and sprayhead blocked/limed up.
3. Pump/seal leaking.
4. No voltage to pump.
5. Pump defective.

REMEDY

Check/replace.

Check/replace.

Check/replace.

Check wiring/CBA.

Replace pump.

Weak beverage

1. Sprayhead

A clean sprayhead must be used for proper extraction.

2. Water temperature

Allow tank to re-heat.

TROUBLESHOOTING (cont.)

MISCELLANEOUS

PROBLEM	PROBABLE CAUSE	REMEDY
"INDEX MOTOR FAULT" CBA has sensed that motor assembly has not rotated timing disk within 15 seconds.	<ol style="list-style-type: none">1. Pod(s) binding pod holder assembly.2. Debris on sensor blocking optical path.3. Timing disk coupler loose/slipping.4. No voltage to motor.5. Motor defective.6. Sensor defective.	<p>Remove blockage.</p> <p>Clean.</p> <p>Tighten. Refer to alignment procedure.</p> <p>Check wiring/CBA.</p> <p>Check/replace.</p> <p>Check/replace.</p>
"REPLACE SEAL SOON/NOW!!!" Counter set for 25000 brews. Early models were set at 5000.	<ol style="list-style-type: none">1. "PM"	<p>Replace sprayhead seal and reset counter.</p>
"PATH CLEAR? ANY SWITCH TO CONTINUE" <i>Formerly "OBSTRUCTION"</i> Triggered when load on motor exceeds .1 amp.	<ol style="list-style-type: none">1. Pods causing obstruction.2. Loose Sprayhead/seal	<p>Clear obstruction. Empty pod bin if needed.</p> <p>Check/replace.</p>
Tripping GFCI breaker.	Tank heater defective.	Check/replace.

COMPONENT ACCESS

This section provides procedures for testing and replacing various major components used in this brewer should service become necessary. Refer to Troubleshooting for assistance in determining the cause of any problem.

WARNING - Inspection, testing, and repair of electrical equipment should be performed only by qualified service personnel. The brewer should be unplugged when servicing, except when electrical tests are required and the test procedure specifically states to plug in the brewer.

WARNING - Disconnect the brewer from the power source before the removal of any panel or the replacement of any component.

All components are accessible by the removal of the top cover or back cover.

Refer to wiring diagrams at the back of this manual when reconnecting wires.

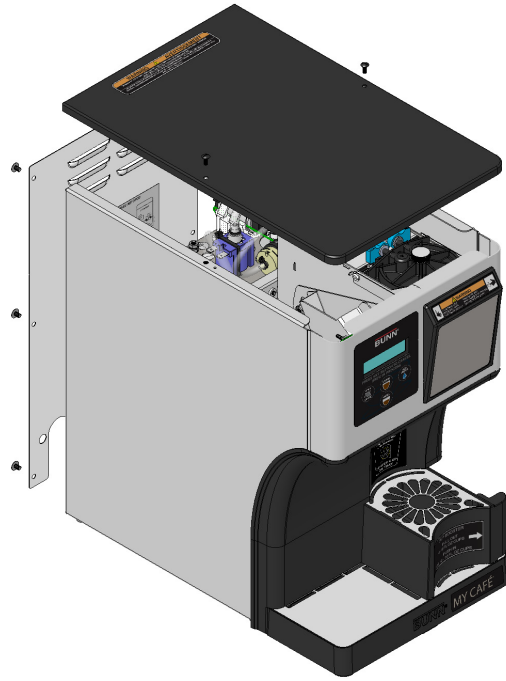

FIG. 10-1 COMPONENT ACCESS

Contents

Access	10
Control Board	11
Inlet Valve	12
Tanks	13
Temperature Probe	14
Vent Valve	15
Air Pumps	16
Water Pumps	17
Flow Meter	18
Ejector Assembly	19
Schematics	25

CONTROL BOARD

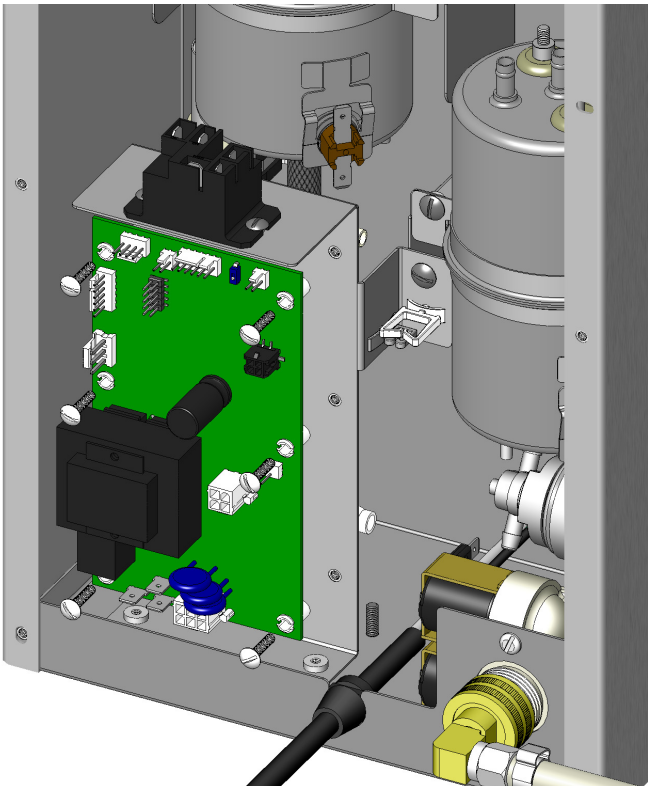

FIG. 11-1 CONTROL BOARD - AutoPod

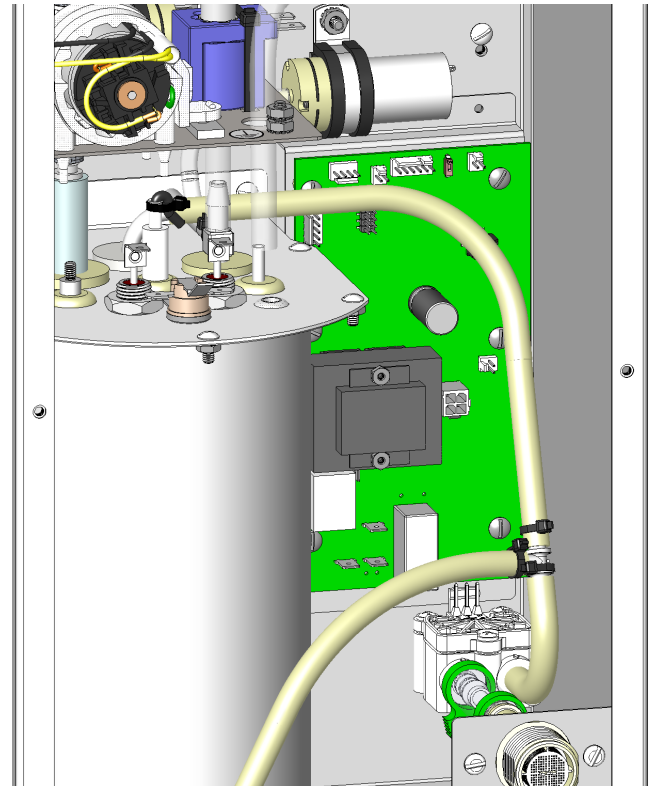

FIG. 11-2 CONTROL BOARD - MyCafé AP

Location:

The Control Board is located inside the back cover.

Test Procedures:

The test procedures for the control board will vary depending upon the problem. Refer to the Troubleshooting section which is divided into three sections, Refill Circuit, Heating Circuit, and Brewing Circuit.

Check for Power to board:

1. Place one meter lead at L1 terminal and the other lead at L2 terminal.
2. With the power connected to brewer, the voltage reading to the board should be the line voltage rated for that model.

If no voltage is present, check wiring to the board.
If voltage is present, and brewer does not power on, replace board.

Removal and Replacement:

1. Disconnect brewer from power source.
2. Disconnect the cord from L1 & L2 on the control board.
3. Disconnect the connectors from the control board.
4. Remove the 6 screws securing the control board to the mounting bracket.
5. Install new board with screws removed in # 4.
6. Re-install wires & connectors.

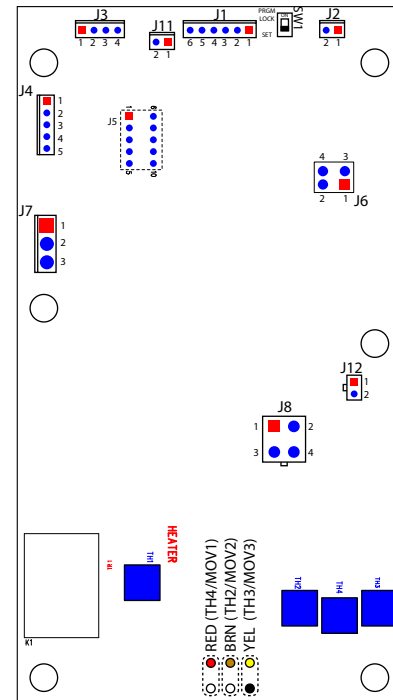

TR 1 – Heater Output (Line Voltage)
 RED – Solenoid (Line Voltage)
 BRN – Solenoid (Line Voltage)
 YEL – Rectified Line Voltage

INLET VALVE

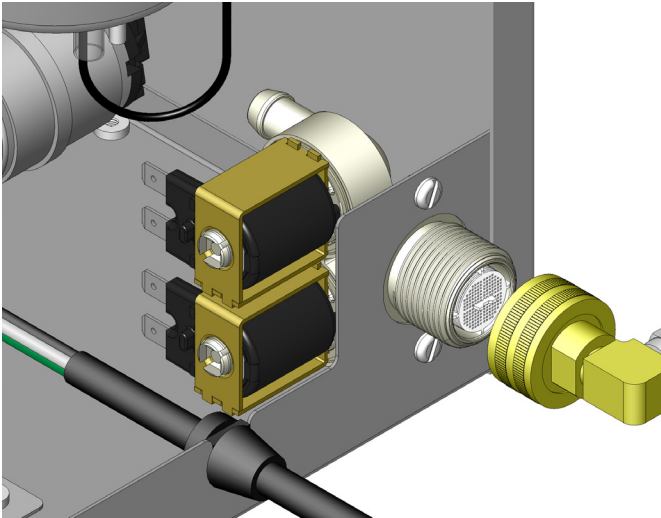

FIG. 12-1 INLET VALVE - AutoPod

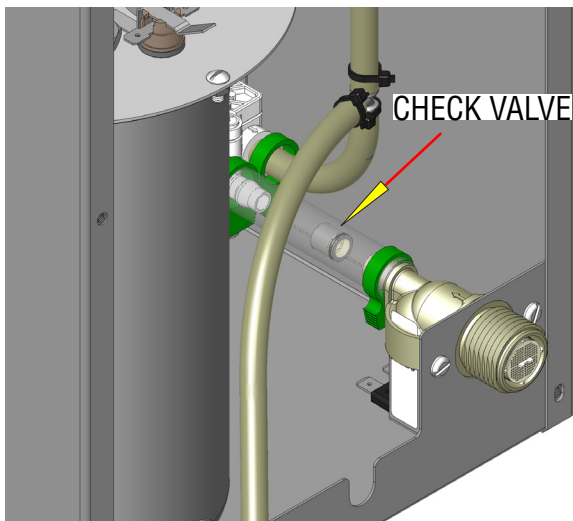

FIG. 12-2 INLET VALVE - MyCafé AP

Location:

The inlet valve is located inside the back cover.

Test Procedures:

1. Refer to the Programming Section for Service Tools/ Test Outputs/Inlet Valve.
2. Be sure container is placed on drip tray before activating valve.
3. Check the valve for coil action. Turn on the valve with the test mode. Listen carefully in the vicinity of the brew valve for a click as the coil pulls the plunger in.

*If no sound is heard as described, proceed to #4.
If the sound is heard as described, there may be a blockage in the valve, hose, tank, or sprayhead.*

Disconnect the brewer from the power source. Remove the valve and inspect for blockage, and de-lime all related areas.

4. Connect the voltmeter leads to the coil terminals. Turn on the valve with the test mode.

Set the meter to AC volts. The indication should be line voltage when activated.

If voltage is present as described, but no coil action is observed, valve is defective. Disconnect leads and check coil for continuity.

Replace valve and test again to verify repair.

If voltage is not present as described, refer to Wiring Diagrams and check the brewer wiring harness. Also check the control board for proper operation.

Removal and Replacement:

1. Disconnect the brewer from the power source.
2. Disconnect wires from the valve.
4. Pinch and Remove hose(s) from the valve.
5. Remove the two screws securing the valve.
6. Install new valve using the two screws.
7. Reconnect wires and hoses to the valve and secure in place with clamps.

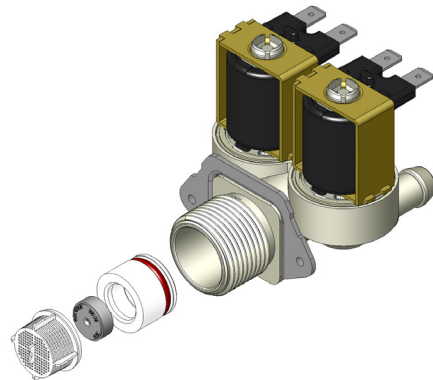

FIG. 12-3 INLET VALVE - AutoPod

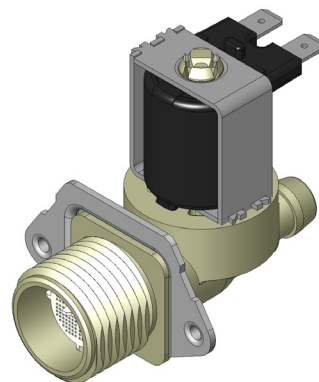

FIG. 12-4 INLET VALVE - MyCafé AP

TANKS

Location:

The tanks are located inside the back access panel.

NOTE: AutoPod tanks are not serviceable.

TANK HEATERS

Test Procedures:

1. With a voltmeter, check voltage across the white wire (120V Models) or red wire (120/208-240V Models) from the terminal block and black wire from the control board. Connect brewer to the power source. The indication must be line voltage (during a heating cycle).
2. Disconnect the brewer from the power source.

If voltage is present as described, proceed to #3.

If voltage is not present as described, refer to the Wiring Diagrams and check wiring harness. If harness checks ok, replace control board.

3. Disconnect the wires from the tank heater.
4. Check for continuity between terminals.

NOTE: There should be no continuity between either terminal to sheath (ground).

If continuity is present as described, reconnect the wires, the tank heater is ok.

If continuity is not present as described, replace the tank.

Removal and Replacement: MyCafé AP

1. Remove the top cover and back access panel.
2. Drain water from the tank.
3. Disconnect all the hoses from the tank.
4. Disconnect the wires from tank heater terminals.
5. Remove two screws securing tank lid to chassis.
6. Remove six screws securing tank lid to tank.
7. Remove two nuts securing heater to tank lid.
8. Installation is the reverse order.

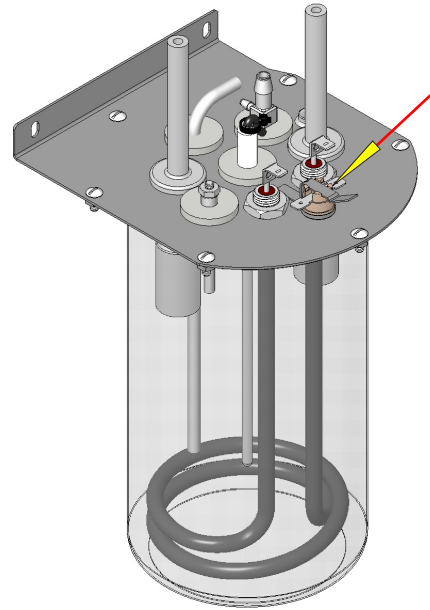

FIG. 13-1 LIMIT THERMOSTAT - MyCafé AP

LIMIT THERMOSTAT

Location:

The limit thermostat is located on the tank lid (MyCafé AP) or on the side of the tank (AutoPod).

Test Procedures:

1. Disconnect the brewer from the power source.
2. Disconnect the wires from the limit thermostat.
3. With an ohmmeter, check for continuity across the limit thermostat terminals.

If continuity is present as described, the limit thermostat is operating properly.

If continuity is not present as described, replace the limit thermostat.

Removal and Replacement:

1. Remove the wires from limit thermostat terminals.
2. Carefully slide the limit thermostat out from under the retaining clip and remove limit thermostat.
3. Carefully slide the new limit thermostat into the retaining clip. Ensure the metal face has good contact with tank.
1. Connect wires to limit thermostat terminals.

TEMPERATURE PROBE

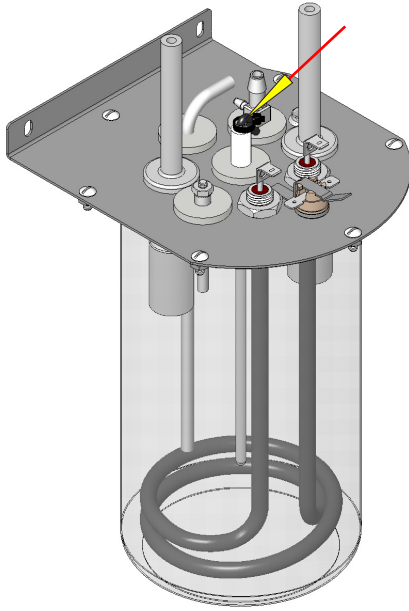

FIG. 14-1 TEMP PROBE - MyCafé AP

If resistance is to specification, replace the control board.

If resistance is not to specification, replace the temperature probe.

Removal and Replacement:

1. Disconnect the brewer from the power source.
2. Disconnect the two pin connector from control board.
3. Pull temperature probe out of it's grommet.
4. Install in reverse order.

Location:

The temperature probe is inserted through the tank lid assembly.

Test Procedures:

1. Disconnect the brewer from the power source.
2. With a DC voltmeter, check voltage across the two wires at J9 on control board (Black probe to black wire, red probe to white wire. refer to FIG 18-2). Connect the brewer to the power source. The indication should be *approximately* between 4vdc cool to 1vdc at ready temperature.
3. Disconnect the brewer from the power source.

If voltage is present as described, circuit is working correctly, check limit thermostat (and TCO on 230V models).

If voltage is not present as described, proceed to #4.

4. Disconnect temperature probe from control board. Check the resistance across the two terminals of the temperature probe. The indication should be *approximately* between 10.5K Ω cool to 870 Ω at ready temperature.

VENT VALVE

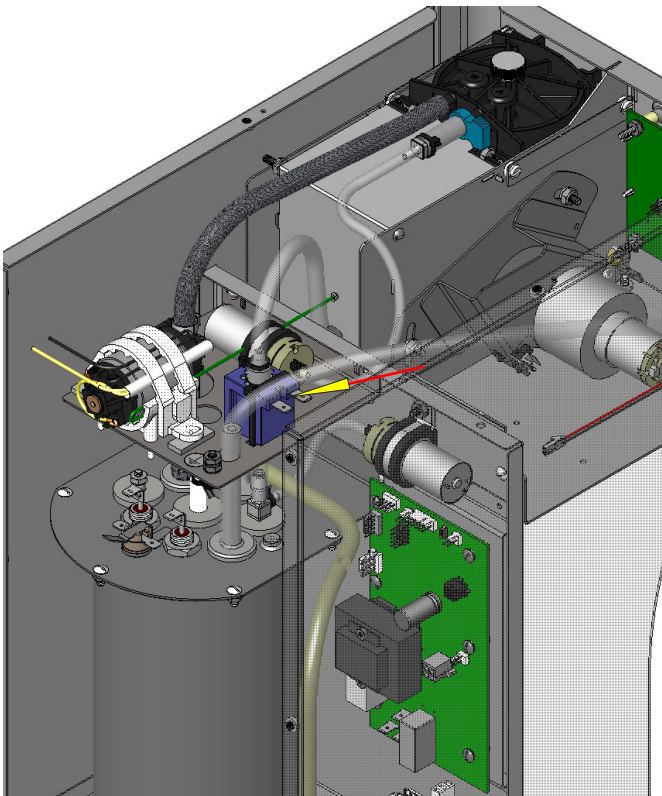

FIG. 15-1 VENT VALVE - MyCafé AP

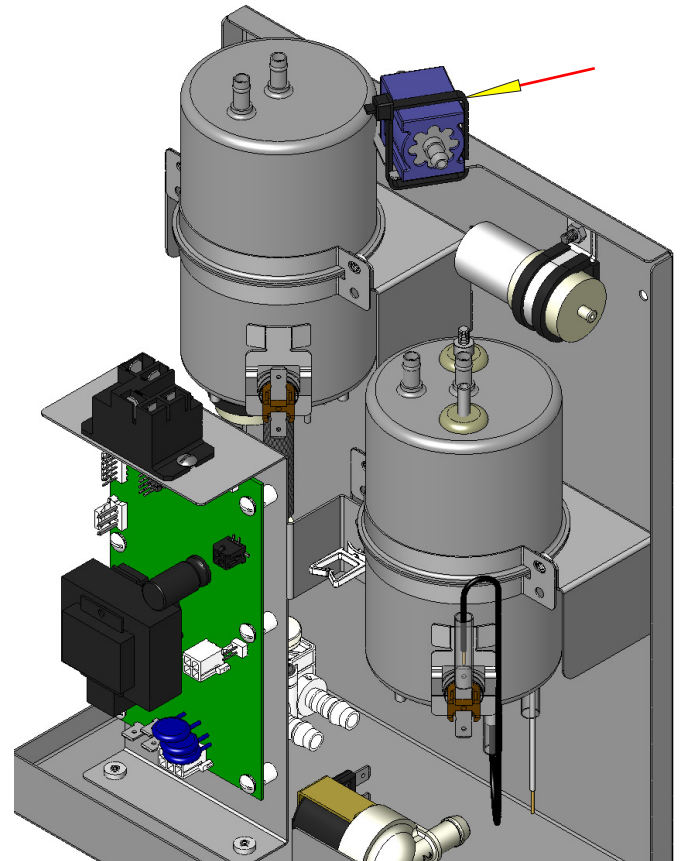

FIG. 15-2 VENT VALVE - AutoPod

Location:

The vent valve is located inside the back access panel.

Function:

The vent valve closes (activates) only during hot water dispense to pressurize tank.

Test Procedures:

1. With a voltmeter, check voltage across the terminals of the vent valve. Activate valve in the "TEST OUTPUTS" program mode. The indication must be 12 vdc.
2. Coil resistance should be $28.8\Omega \pm 10\%$.

Removal and Replacement:

1. Disconnect the brewer from the power source.
2. Disconnect the connectors from solenoid.
3. Cut cable tie(s) securing solenoid.
4. Disconnect hose from solenoid.
5. Install in reverse order.

AIR PUMPS

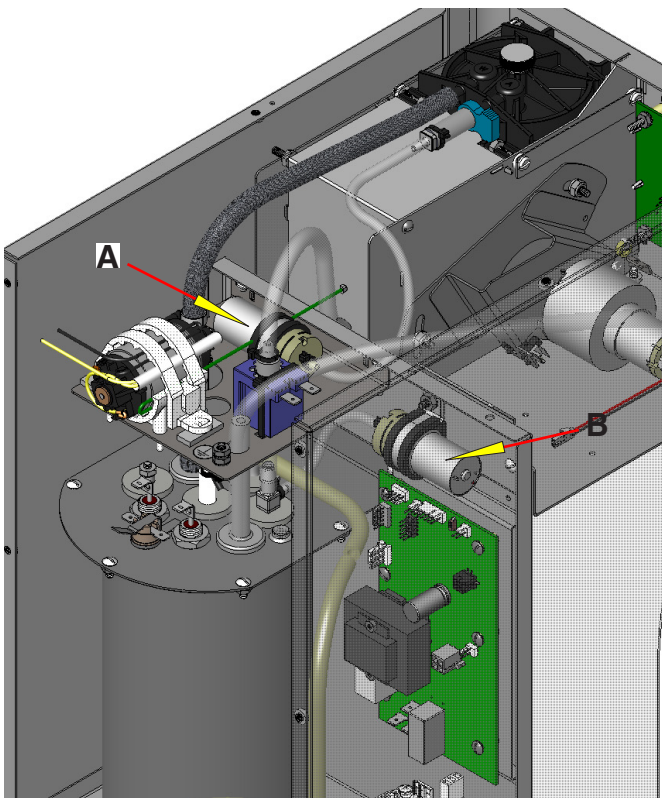

FIG. 16-1 AIR PUMPS - MyCafé AP

Location:

The air pumps are located inside the back access panel.

Function:

A: Blows moisture out of pod after brewing, before being ejected.

B: Pressurizes tank during hot water dispense in conjunction with air vent valve.

Test Procedures:

1. Disconnect the brewer from the power source.
2. With a DC voltmeter, check voltage across the two wires at motor (Black probe to brown wire, red probe to orange wire). Connect the brewer to the power source. Activate motor(s) in the "TEST OUTPUTS" program mode. The indication must be 12 vdc.
3. Disconnect the brewer from the power source. If voltage is present as described, circuit is working correctly, If voltage is not present as described, proceed to #4.
4. Disconnect two pin connector from motor. Check the resistance across the two terminals of the motor. The indication should be *approximately* 21.6 - 26.4 Ω .

If resistance is to specification, replace the control board.

If resistance is not to specification, replace the motor.

Removal and Replacement:

1. Disconnect the brewer from the power source.
2. Disconnect the two pin connector for motor.
3. Remove screw securing motor clamp.
4. Disconnect hose from motor.
5. Install in reverse order.

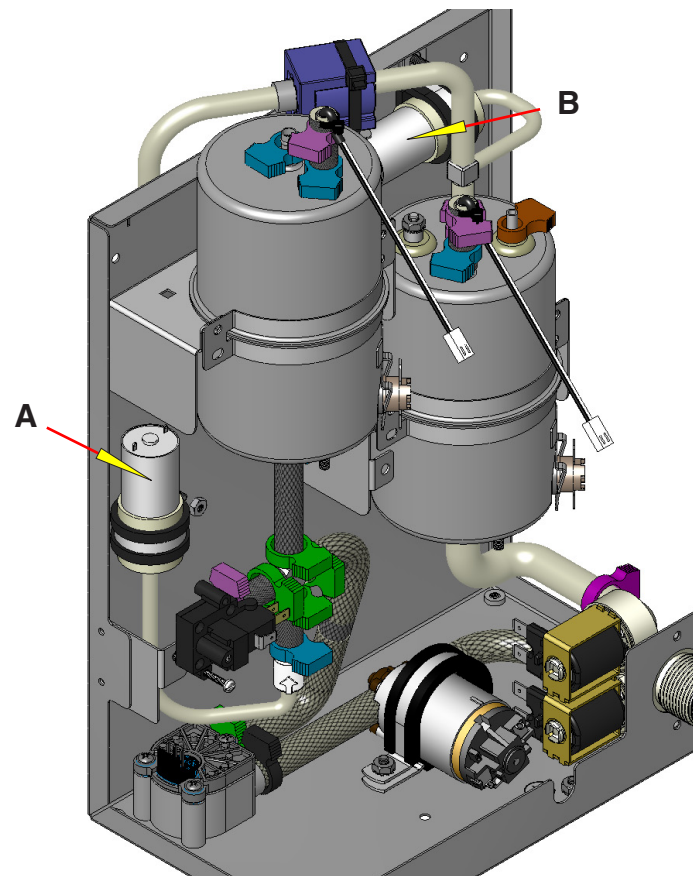

FIG. 16-2 AIR PUMPS - AutoPod

WATER PUMP

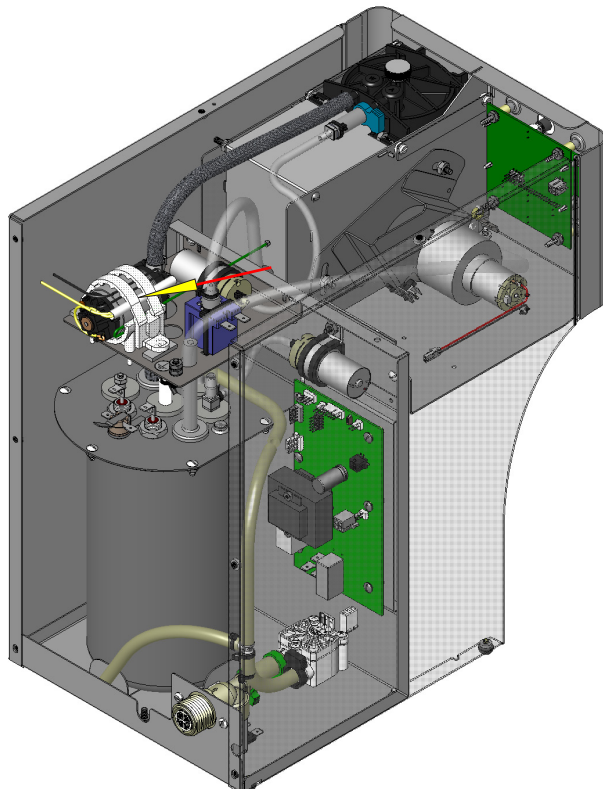

FIG. 17-1 WATER PUMP - MyCafé AP

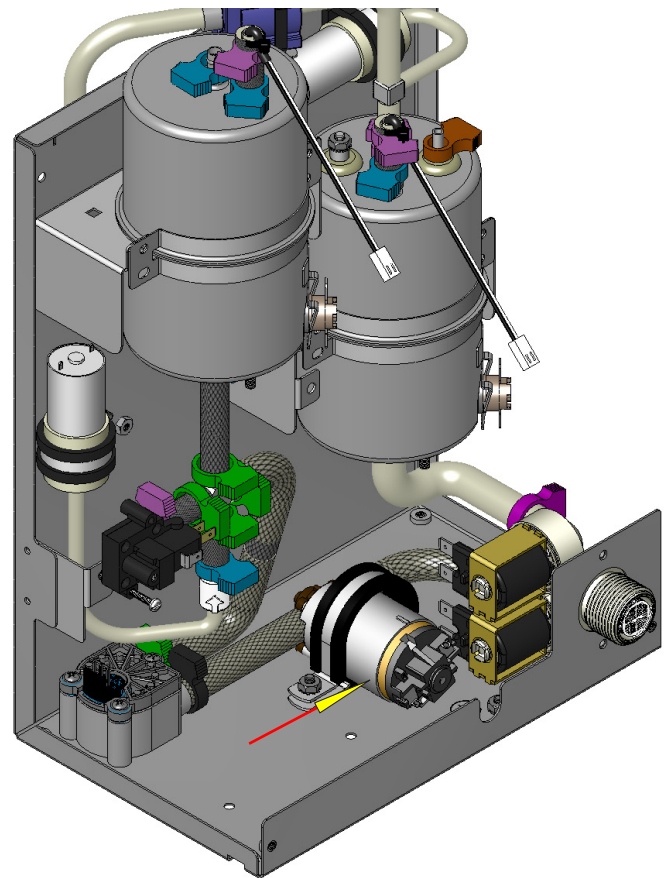

FIG. 17-2 WATER PUMP - AutoPod

Location:

The vent valve is located inside the back access panel.

Function:

The water pump (boost) on AutoPod pressurizes the brew tank during brew cycle. The water pump on My-Cafe AP pressurizes the sprayhead during brew cycle.

Test Procedures:

1. With a voltmeter, check voltage across the terminals of the motor. Activate motor in the "TEST OUTPUTS" program mode. The indication must be 120 vdc on all models. **NOTE:** 230v models provide 120vdc to the motor. 230v models have capacitors installed on motor for CE compliance. Continuity is not a viable test for this motor.

Removal and Replacement:

1. Disconnect the brewer from the power source.
2. Loosen clamp.
3. Disconnect harness to motor.
4. Remove clamps and hoses from motor.
5. Install in reverse order.

FLOW METER

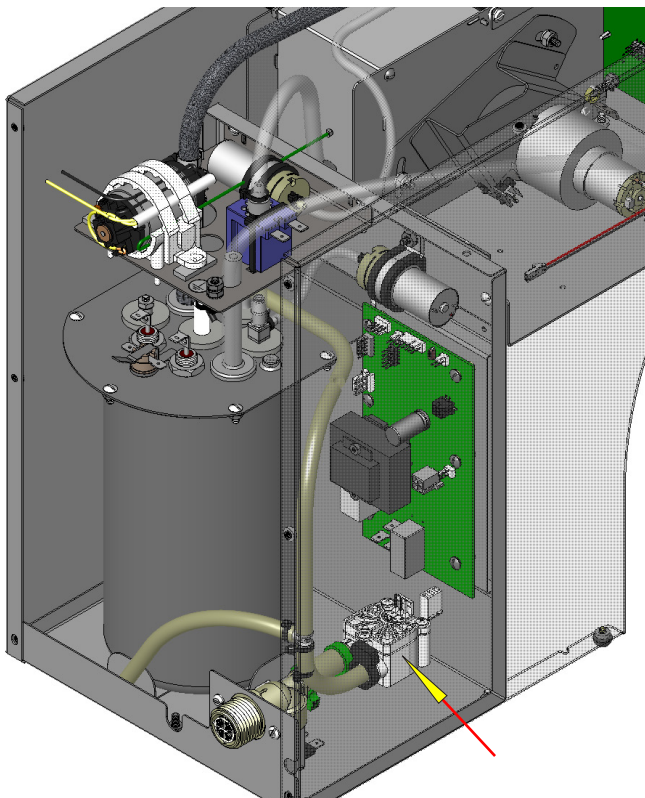

FIG. 18-1 FLOW METER - MyCafé AP

Location:

MyCafe-AP: Below main CBA.

AutoPod: Behind main CBA.

Function:

A: Monitors incoming water flow rate (counts pulses).

Test Procedures:

1. Place container under brew chamber.
2. In "SERVICE TOOLS" select "TEST OUTPUTS".
3. Scroll to "WaterInlet". Press "ON".
If you see the number in upper right corner of display counting, flow meter is working correctly.
If the number in upper right corner of display is not counting, go to # 4.
4. Disconnect the brewer from the power source.
5. With a DC voltmeter, check voltage across the two wires at J7 on main CBA (Black probe to black wire, red probe to red wire. Connect the brewer to the power source. The indication must be 12 vdc.
3. Disconnect the brewer from the power source.

If supply voltage is present as described, CBA is working correctly, replace flow meter.

If supply voltage is not present as described, replace CBA.

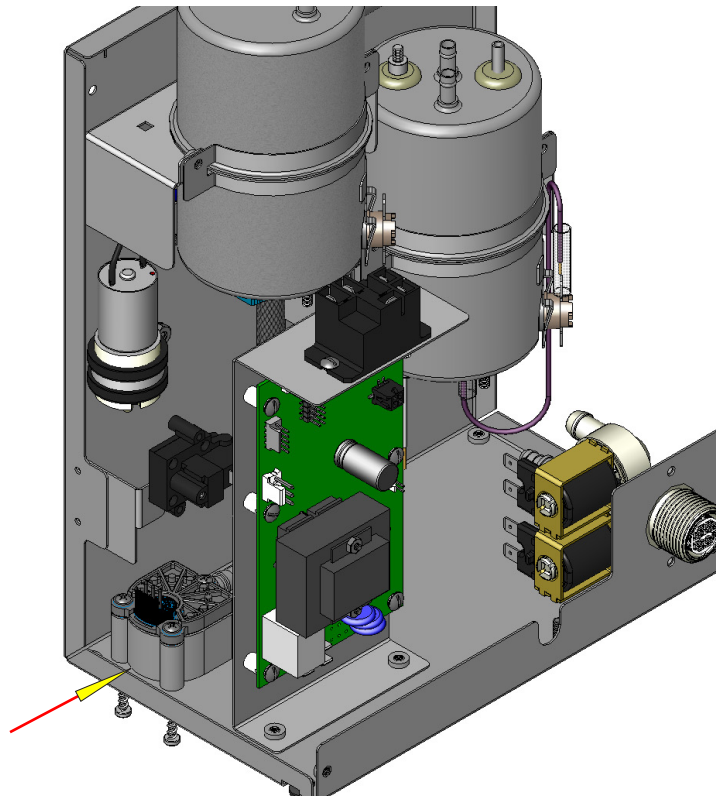
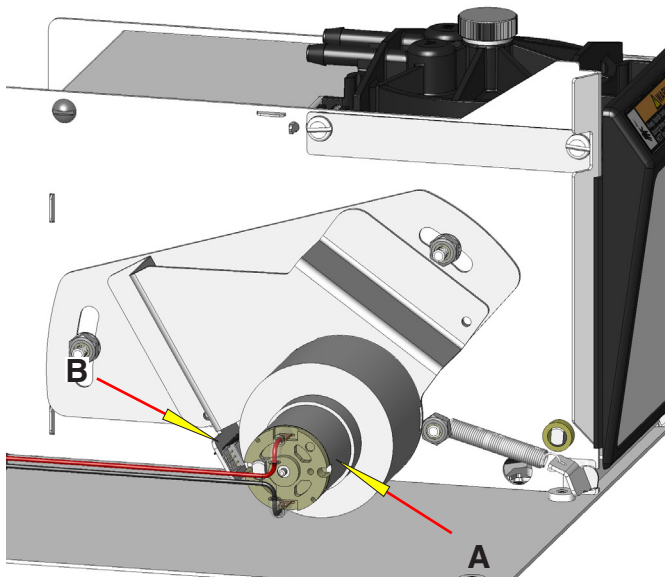

FIG. 18-2 FLOW METER - AutoPod

Removal and Replacement:

1. Disconnect the brewer from the power source.
2. Remove back panel.
3. AutoPod: Remove main CBA bracket assembly (2 screws from underneath brewer) Disconnect hoses and the 3 pin connector from flow meter.
4. Remove 3 screws securing flow meter from underneath brewer.
5. MyCafe-AP: Disconnect hoses and 3 pin connector from flow meter.
6. Install in reverse order.

EJECTOR ASSEMBLY



1. With a voltmeter, check voltage across the terminals of the motor. Activate motor in the "TEST OUTPUTS" program mode. The indication must be 12 vdc on all models. Continuity is not a viable test for this motor.

FIG. 18-1 INDEX MOTOR/SENSOR - MyCafé AP

Location:

The index motor & sensor are located on the ejector assembly. FIG 18-1.

Function:

A: Motor drives the pod holder from brew position to open position to dump position.

B: Photosensor detects position of pod holder by reading slots in motor disk.

Test Procedures:

1. Go to "TEST INDEX MOTOR" in the "TEST OUTPUTS" mode.
Press & hold "DUMP" (OPEN/CLOSE button) drives the pod holder back to the pod ejection position.
Press & hold "LOAD" (HOT WATER button) drives the pod holder out to the door open position.
- "L" indicates the assembly is in load position FIG 19-1a/b.
 - "B" indicates the assembly is in home position FIG 19-2a/b.
 - "D" indicates the assembly is in dump position FIG 19-3a/b.
 - "□" indicates the photo sensor is not blocked by the disk.
 - "■" indicates the photo sensor is blocked by the disk.

CONTINUED

EJECTOR ASSEMBLY

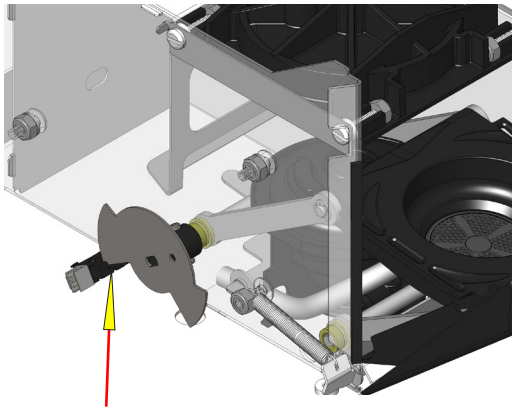
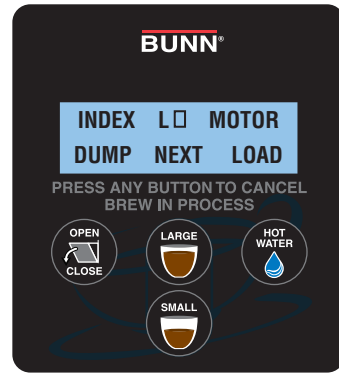

FIG 19-1a UNBLOCKED



**FIG 19-1b
LOAD POSITION**

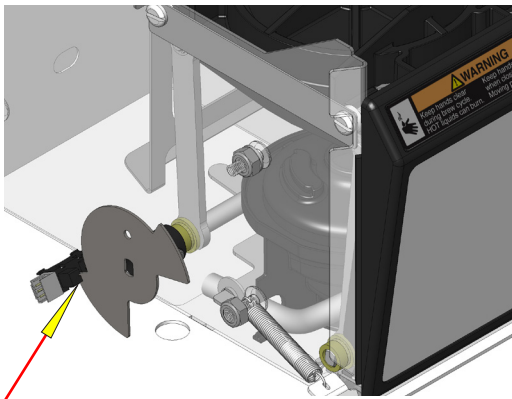
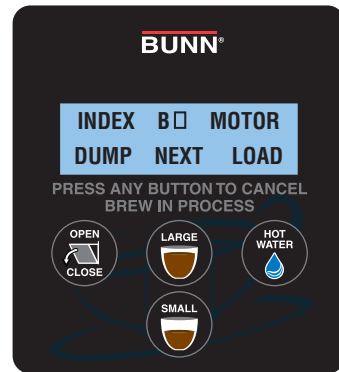

FIG 19-2a UNBLOCKED



**FIG 19-2b
HOME POSITION**

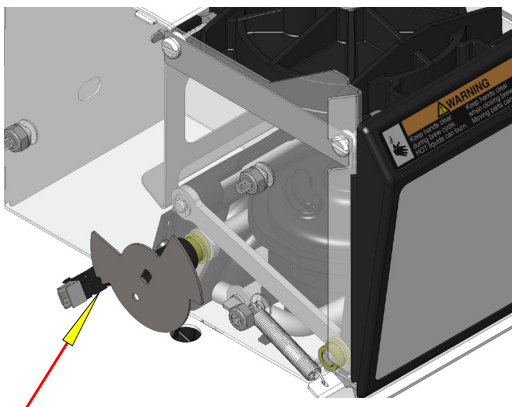
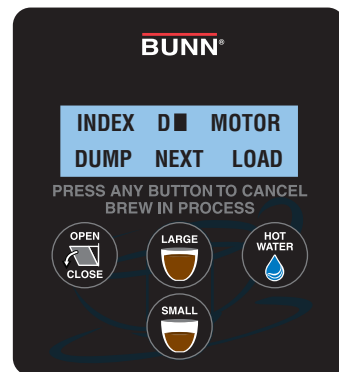

FIG 19-3a BLOCKED



**19-3b
DUMP POSITION**

CONTINUED

INDEX MOTOR & SENSOR

Ejector Assembly:

Removal and Replacement:

AutoPod & MyCafé-AP

1. Unplug brewer.
2. Remove drip tray and bin assemblies.
3. Remove top cover and rear panel.
4. Pull out on bottom of door bezel. Slide bezel up and off of door. FIG 20-1.
5. Remove 2 clamps and hoses from sprayhead assembly.
6. Remove vent valve hose from back of ejector.
7. Disconnect harnesses from index motor, sensor and display board.
8. Remove 5 screws from housing. FIG 20-2.
9. Spread back of housing to clear bracket assembly and slide housing towards front to separate from chassis. FIG 20-3.
10. Remove 3 screws from rear mounting bracket. FIG 20-4.
11. Separate ejector from chassis. FIG 5.



FIG 20-1 Remove bezel

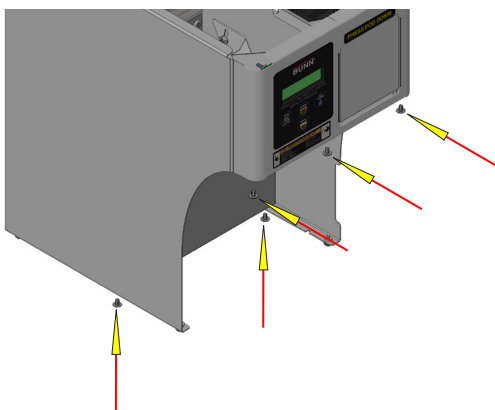

FIG 20-2 Remove 5 screws

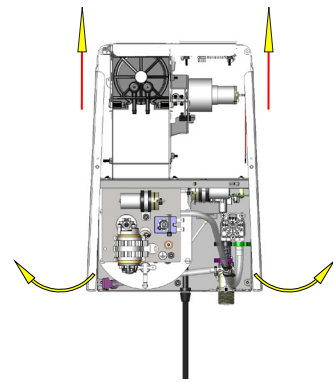

FIG 20-3 Spread back of housing.

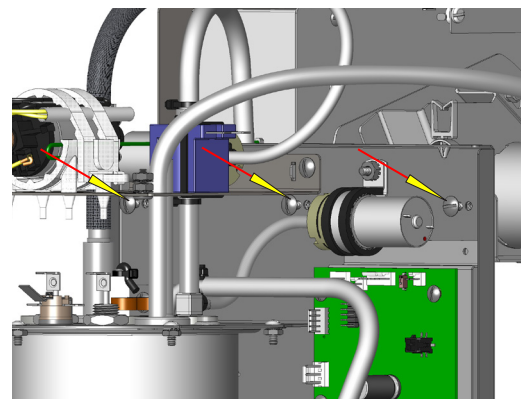

FIG 20-4 Remove 3 screws

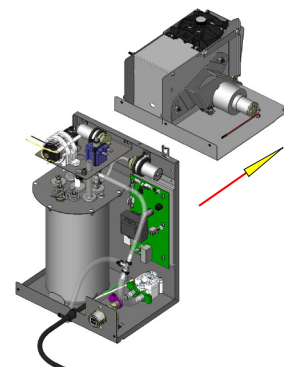

FIG 20-5 Separate ejector from chassis

CONTINUED

EJECTOR ASSEMBLY

Index Motor Assembly: Removal and Replacement: MyCafé-AP ONLY

1. Press "OPEN/CLOSE" button to open pod door. If you can not operate motor assembly, then manually move pod holder assembly out to the load position.
2. Unplug brewer.
3. Remove top cover.
4. Loosen top Allen screw (farthest from motor). FIG 21-1.
5. Remove plastic plug from ejector floor. Insert Allen wrench through hole and loosen bottom Allen screw (farthest from motor). FIG 21-2.
6. Remove 2 nuts from motor mounting bracket. FIG 21.3.
7. Remove motor assembly.

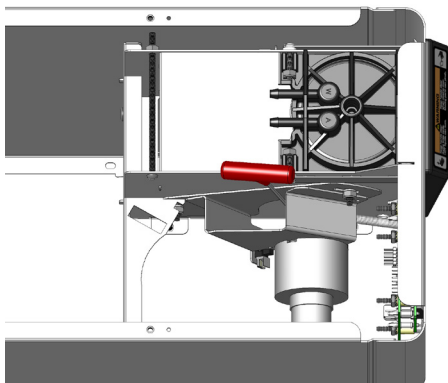

FIG 21-1 Loosen top Allen screw.

Front removed for clarity.

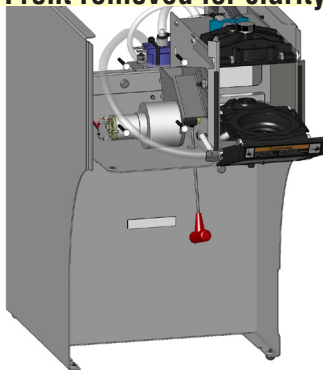

FIG 21-2 Loosen bottom Allen screw.

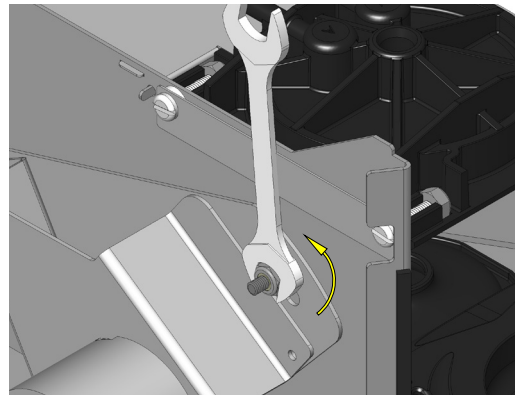

FIG 21-3 Remove mounting nuts.

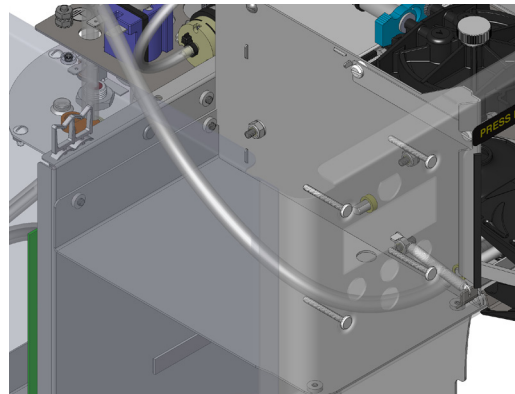

FIG 21-4 Motor removed.

CONTINUED

EJECTOR ASSEMBLY

Installation:

1. Connect motor and sensor harness to the new motor assembly.
2. Connect brewer to power source. Press "OPEN/CLOSE" button to open pod door. (or use the "TEST OUTPUTS" to move it to "LOAD POSITION").
3. Unplug brewer.
4. Verify motor assembly is in the OPEN/LOAD position. FIG 22-1.
5. Install motor assembly and snug mounting nuts.
6. Verify door assembly is open. Tighten allen screws.
NOTE: DO NOT TIGHTEN ALLEN SCREWS UNTIL MOTOR BRACKET IS SECURE AGAINST EJECTOR WALL.
7. Install "puck" into pod holder. FIG 22-2.
8. Remove thumbscrew and sprayhead. If necessary, use alignment tool to push sprayhead out.
NOTE: It will be easier to get your hand inside if you use the "TEST INDEX MOTOR" to move pod holder all the way to the back position.
9. Power up brewer and Press "OPEN/CLOSE" button to close pod door.
10. Slightly loosen 2 nuts securing motor mounting bracket to ejector wall. FIG 22-3.
11. Insert alignment tool. FIG 22-4. Rotate motor assembly (FIG 22-5) with adjustable wrench until alignment tool slips into puck. Tighten nuts.
NOTE: Alignment tool should drop into alignment puck with little to no force. If force is required, repeat step 11.
12. Remove tools. Cycle door open/closed a few times and test for proper operation. If any error codes are displayed, repeat the alignment procedure.
13. Install sprayhead and thumbscrew.

⚠ WARNING: IMPROPER ALIGNMENT COULD CAUSE LEAKAGE OF HOT WATER AT THE SPRAYHEAD SEAL.

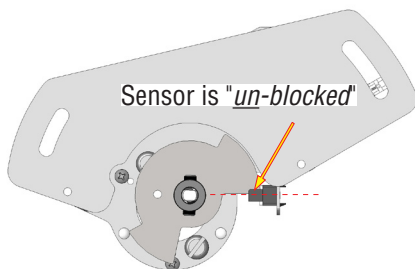

FIG 22-1 Motor in open position.

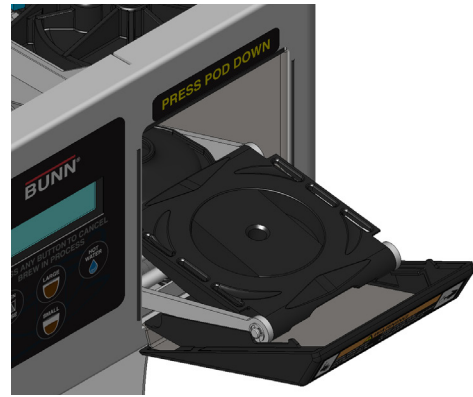

FIG 22-2 Install "puck".

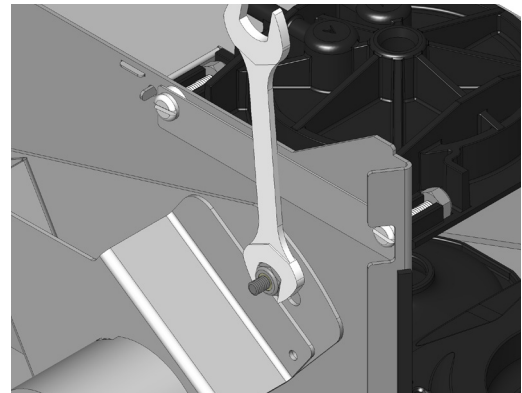

FIG 22-3 Slightly loosen both nuts.

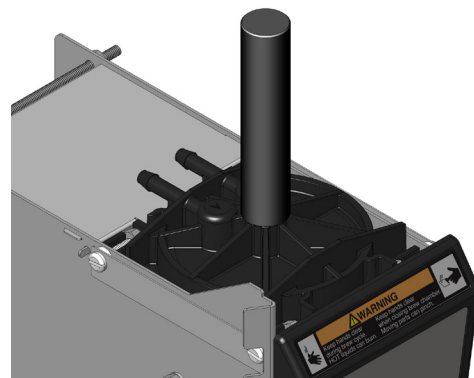

FIG 22-4 Insert alignment tool.

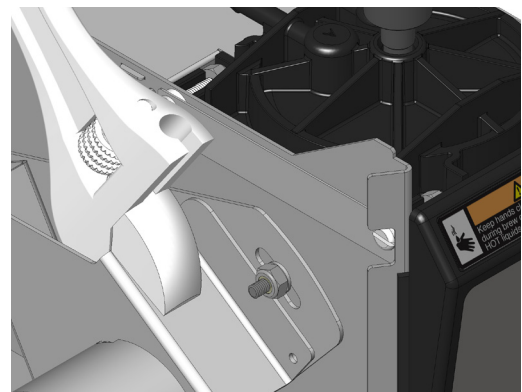

FIG 22-5 Rotate motor assembly.

EJECTOR ASSEMBLY

Check valve replacement: All models

1. Connect brewer to power source. Use the “TEST OUTPUTS/TEST INDEX MOTOR” to move it to “DUMP POSITION”.
2. Unplug brewer.
3. Remove sprayhead/seal assembly:
AutoPod: Unscrew sprayhead/seal assembly.
My Café AP: Remove top cover. Remove thumbscrew. FIG 24-1. Open door and remove sprayhead/seal assembly (You may need to push sprayhead/seal assembly down with a screwdriver). FIG 24-2.
4. Remove check valve with a spring hook or dental pick. FIG 24-3.



FIG 24-1 Remove thumbscrew

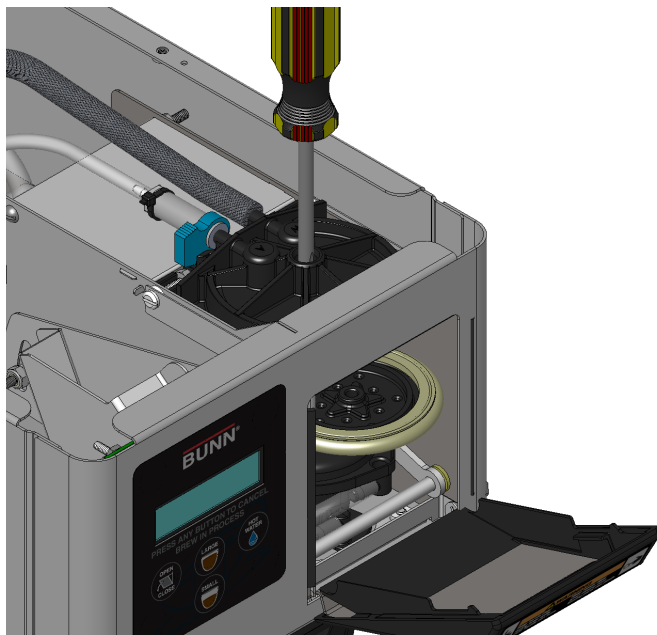

FIG 24-2 Remove sprayhead/seal assembly

5. If check valve pulls apart, remove remaining piece with a spring hook or dental pick.
6. Install new check valve with O-ring end in first.
WARNING: NEVER RE-USE CHECK VALVE AFTER IT HAS BEEN PULLED OUT.
7. Remove seal from sprayhead.
8. Check and clean the sprayhead. The sprayhead holes must always remain open. Clean all the holes in the plastic sprayhead to remove any mineral deposits. Wash and rinse in sink.
9. When reassembling sprayhead, be sure to have seal installed with *ridge* facing up. Fig 24-4.
10. Install sprayhead/seal assembly (and thumbscrew and washer if equipped). Install top cover and screws.
11. Power up brewer and Press “OPEN/CLOSE” button to reset pod holder to home position.

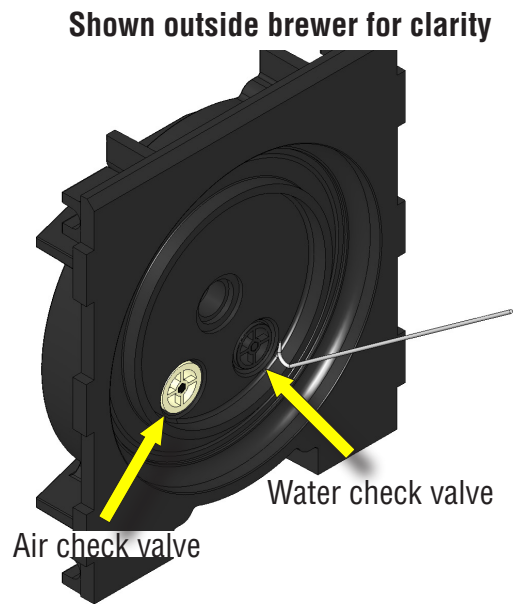

FIG 24-3

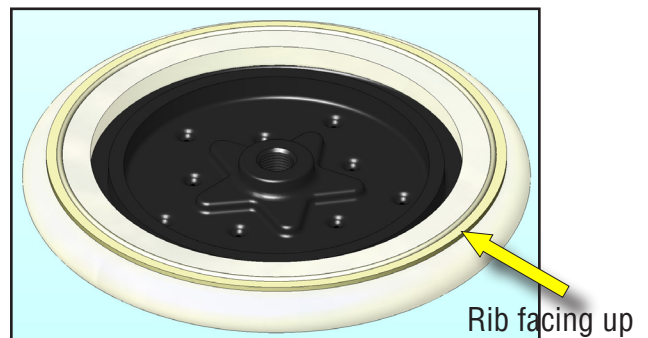
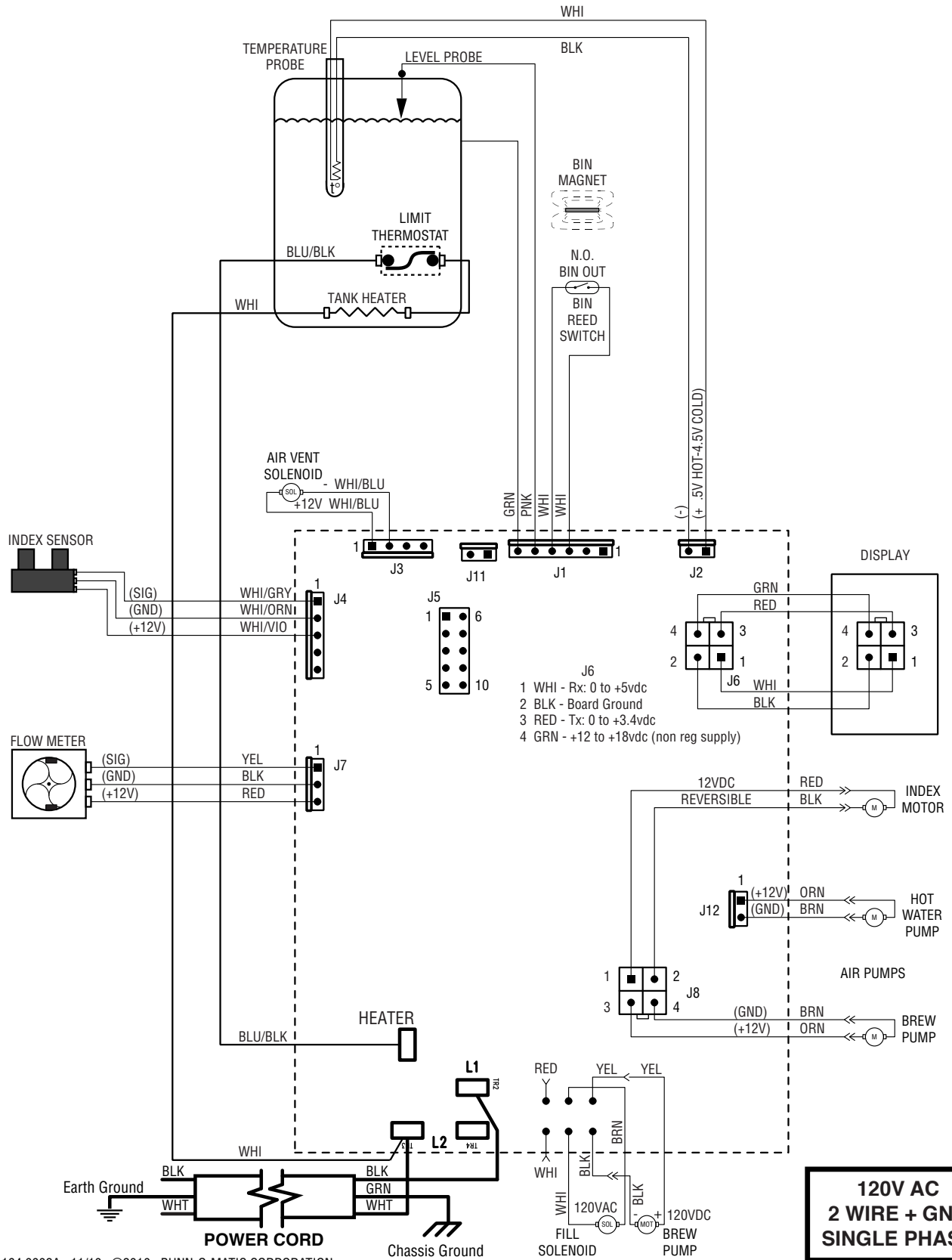

FIG 24-4

SCHEMATIC WIRING DIAGRAM - My Café AP



41164.0002A 11/10 ©2010 BUNN-O-MATIC CORPORATION

SCHEMATIC WIRING DIAGRAM AUTOPOD

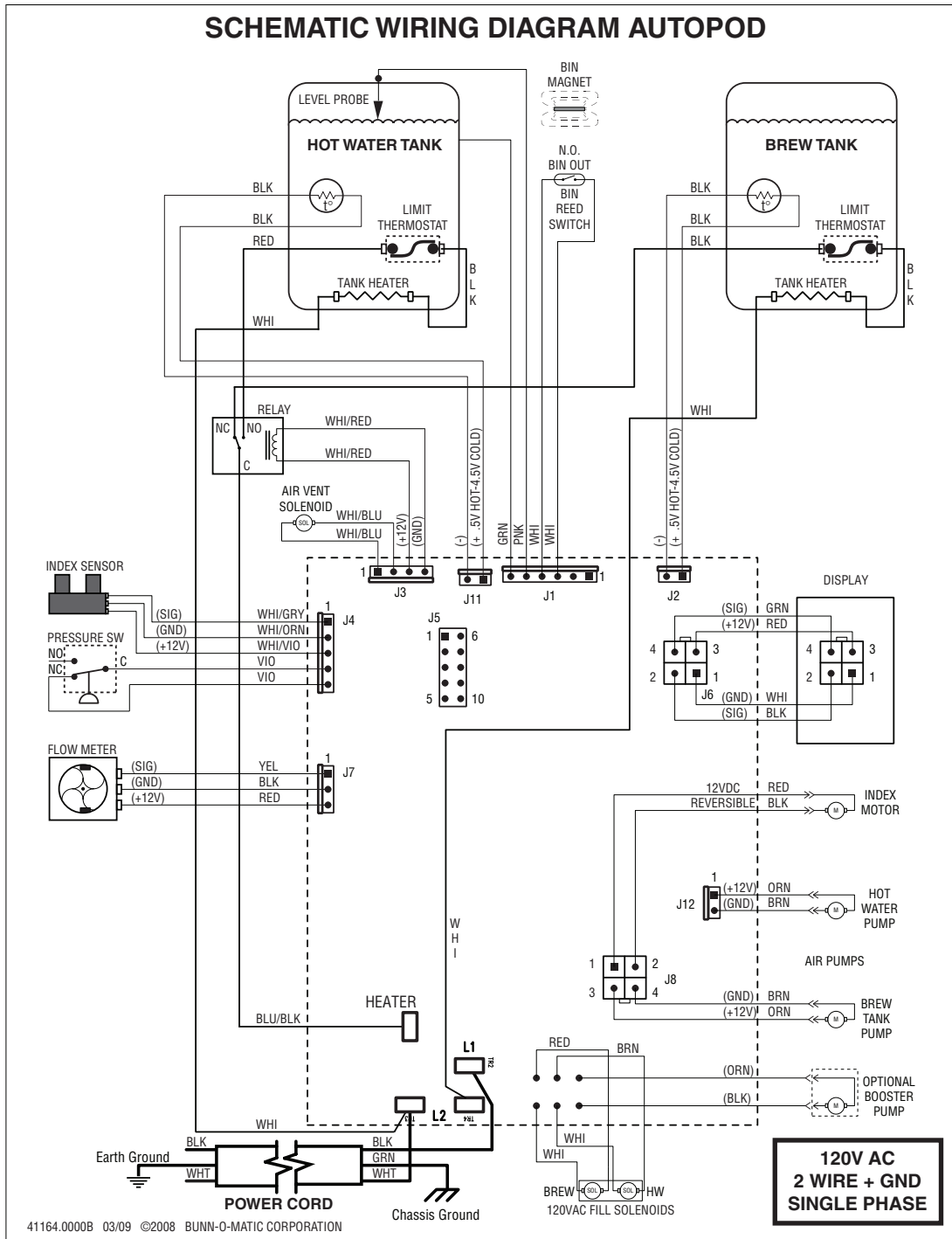

SCHEMATIC WIRING DIAGRAM AUTOPOD

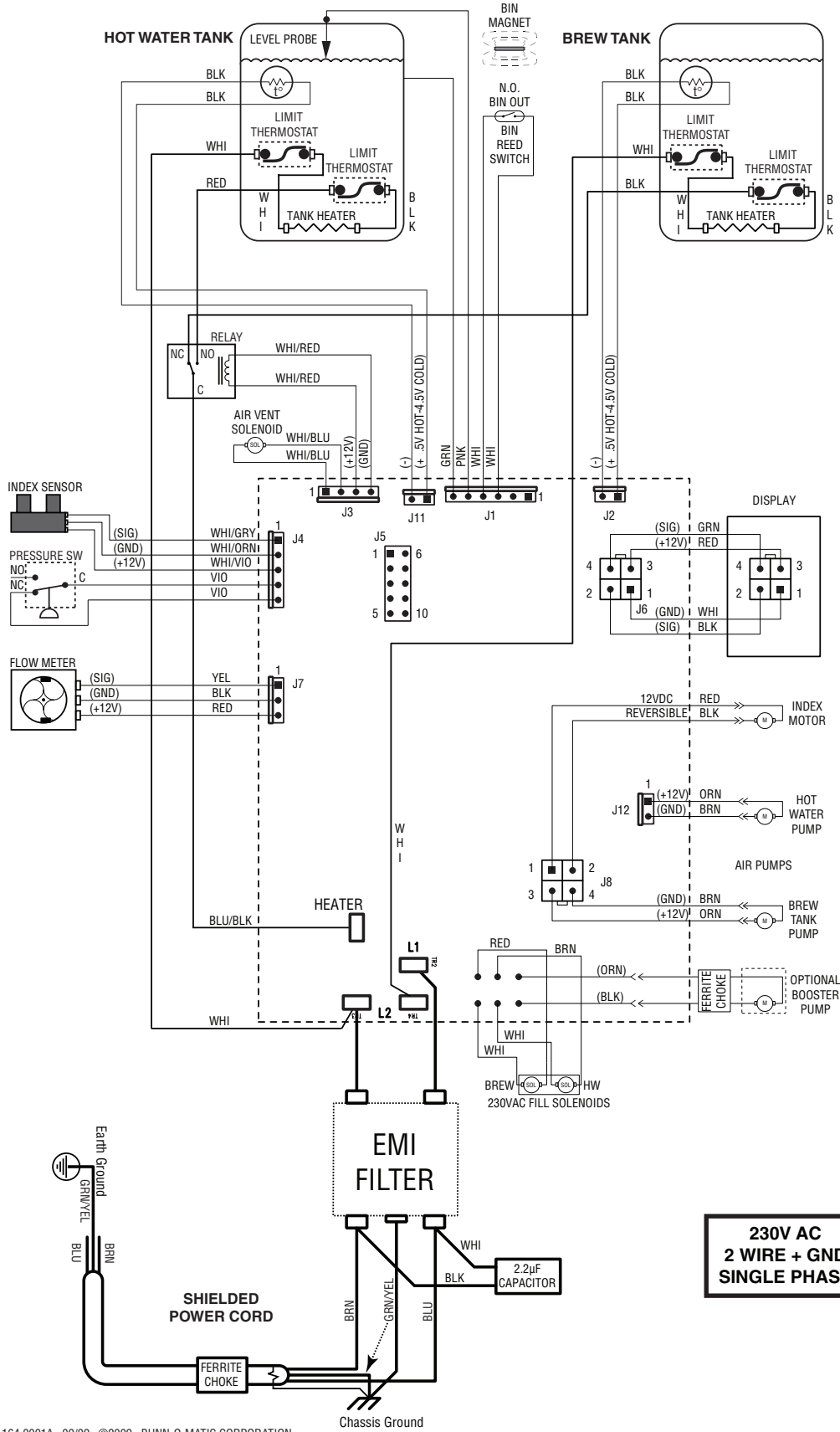

41164.0001A 09/09 ©2009 BUNN-O-MATIC CORPORATION