BUNN®

392®



OPERATING & INSTALLATION MANUAL

BUNN-O-MATIC CORPORATION

POST OFFICE BOX 3227

SPRINGFIELD, ILLINOIS 62708-3227

PHONE: (217) 529-6601 FAX: (217) 529-6644

To ensure you have the latest revision of the manual or to obtain the illustrated parts catalog, please visit the Bunn-O-Matic website, at www.bunn.com. This is absolutely FREE, and the quickest way to obtain the latest catalog and manual updates. Contact Bunn-O-Matic Corporation at 1-800-286-6070 to obtain a paper copy of the required Illustrated Parts Catalog mailed via U.S. Postal Service.



BUNN-O-MATIC COMMERCIAL PRODUCT WARRANTY

Bunn-O-Matic Corp. ("BUNN") warrants equipment manufactured by it as follows:

- 1) Airpots, thermal carafes, decanters, GPR servers, iced tea/coffee dispensers, MCP/MCA pod brewers thermal servers and Thermofresh servers (mechanical and digital)- 1 year parts and 1 year labor.
- 2) All other equipment - 2 years parts and 1 year labor plus added warranties as specified below:
 - a) Electronic circuit and/or control boards - parts and labor for 3 years.
 - b) Compressors on refrigeration equipment - 5 years parts and 1 year labor.
 - c) Grinding burrs on coffee grinding equipment to grind coffee to meet original factory screen sieve analysis - parts and labor for 4 years or 40,000 pounds of coffee, whichever comes first.

These warranty periods run from the date of installation BUNN warrants that the equipment manufactured by it will be commercially free of defects in material and workmanship existing at the time of manufacture and appearing within the applicable warranty period. This warranty does not apply to any equipment, component or part that was not manufactured by BUNN or that, in BUNN's judgment, has been affected by misuse, neglect, alteration, improper installation or operation, improper maintenance or repair, non periodic cleaning and descaling, equipment failures related to poor water quality, damage or casualty. In addition, the warranty does not apply to replacement of items subject to normal use including but not limited to user replaceable parts such as seals and gaskets. This warranty is conditioned on the Buyer 1) giving BUNN prompt notice of any claim to be made under this warranty by telephone at (217) 529-6601 or by writing to Post Office Box 3227, Springfield, Illinois 62708-3227; 2) if requested by BUNN, shipping the defective equipment prepaid to an authorized BUNN service location; and 3) receiving prior authorization from BUNN that the defective equipment is under warranty.

THE FOREGOING WARRANTY IS EXCLUSIVE AND IS IN LIEU OF ANY OTHER WARRANTY, WRITTEN OR ORAL, EXPRESS OR IMPLIED, INCLUDING, BUT NOT LIMITED TO, ANY IMPLIED WARRANTY OF EITHER MERCHANTABILITY OR FITNESS FOR A PARTICULAR PURPOSE. The agents, dealers or employees of BUNN are not authorized to make modifications to this warranty or to make additional warranties that are binding on BUNN. Accordingly, statements by such individuals, whether oral or written, do not constitute warranties and should not be relied upon.

If BUNN determines in its sole discretion that the equipment does not conform to the warranty, BUNN, at its exclusive option while the equipment is under warranty, shall either 1) provide at no charge replacement parts and/or labor (during the applicable parts and labor warranty periods specified above) to repair the defective components, provided that this repair is done by a BUNN Authorized Service Representative; or 2) shall replace the equipment or refund the purchase price for the equipment.

THE BUYER'S REMEDY AGAINST BUNN FOR THE BREACH OF ANY OBLIGATION ARISING OUT OF THE SALE OF THIS EQUIPMENT, WHETHER DERIVED FROM WARRANTY OR OTHERWISE, SHALL BE LIMITED, AT BUNN'S SOLE OPTION AS SPECIFIED HEREIN, TO REPAIR, REPLACEMENT OR REFUND.

In no event shall BUNN be liable for any other damage or loss, including, but not limited to, lost profits, lost sales, loss of use of equipment, claims of Buyer's customers, cost of capital, cost of down time, cost of substitute equipment, facilities or services, or any other special, incidental or consequential damages.

392, A Partner You Can Count On, AutoPOD, AXIOM, BrewLOGIC, BrewMETER, Brew Better Not Bitter, BrewWISE, BrewWIZARD, BUNN Espresso, BUNN Family Gourmet, BUNN Gourmet, BUNN Pour-O-Matic, BUNN, BUNN with the stylized red line, BUNNlink, Bunn-O-Matic, Bunn-O-Matic, BUNNserve, BUNNSERVE with the stylized wrench design, Cool Froth, DBC, Dr. Brew stylized Dr. design, Dual, Easy Pour, EasyClear, EasyGard, FlavorGard, Gourmet Ice, Gourmet Juice, High Intensity, iMIX, Infusion Series, Intellisteam, My Café, Phase Brew, PowerLogic, Quality Beverage Equipment Worldwide, Respect Earth, Respect Earth with the stylized leaf and coffee cherry design, Safety-Fresh, savemycoffee.com, Scale-Pro, Silver Series, Single, Smart Funnel, Smart Hopper, SmartWAVE, Soft Heat, SplashGard, The Mark of Quality in Beverage Equipment Worldwide, ThermoFresh, Titan, trifacta, Velocity Brew, Air Brew, Air Infusion, Beverage Bar Creator, Beverage Profit Calculator, Brew better, not bitter., BUNNsource, Coffee At Its Best, Cyclonic Heating System, Daypart, Digital Brewer Control, Element, Nothing Brews Like a BUNN, Pouring Profits, Signature Series, Tea At Its Best, The Horizontal Red Line, Ultra are either trademarks or registered trademarks of Bunn-O-Matic Corporation. The commercial trifacta® brewer housing configuration is a trademark of Bunn-O-Matic Corporation.

USER NOTICES

Carefully read and follow all notices in this manual and on the equipment. All labels on the equipment should be kept in good condition. Replace any unreadable or damaged labels.

CAUTION WARMERS AND SURFACES ARE HOT

#12364.0000

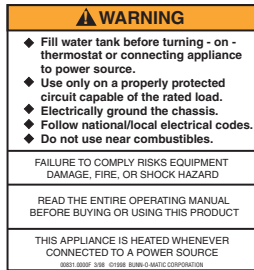

00831.0000



00658.0000

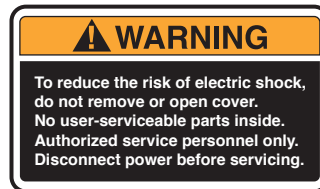

#37881.0000



03408.0002



03409.0002

ELECTRICAL REQUIREMENTS

CAUTION - The brewer must be disconnected from the power source until specified in *Initial Set-Up*.

All models have an attached cordset and plug.

US models require 2-wire grounded service rated 120 volts ac, 15 amp, single phase, 60 Hz.

"A" models require 2-wire, grounded service rated 220-240 volts ac, 10 amp, single phase, 50/60 Hz.

"B" models require 2-wire, rated 100 volts ac, 15.0 amp, single phase, 50/60 Hz.

Electrical Hook-Up

CAUTION – Improper electrical installation will damage electronic components.

1. An electrician must provide electrical service as specified on the data plate.
2. Using a voltmeter, check the voltage and color coding of each conductor at the electrical source.

CE Requirements:

- This appliance must be installed in locations where it can be overseen by trained personnel.
- For proper operation, this appliance must be installed where the temperature is between 5°C to 35°C.
- Appliance shall not be tilted more than 10° for safe operation.
- An electrician must provide electrical service as specified in conformance with all local and national codes.
- This appliance must not be cleaned by water jet.
- This appliance is not intended for use by persons (including children) with reduced physical, sensory or mental capabilities, or lack of experience and knowledge, unless they have been given instructions concerning use of this appliance by a person responsible for its safety.
- Children should be supervised to ensure they do not play with the appliance.
- If the power cord is ever damaged, it must be replaced by the manufacturer or authorized service personnel with a special cord available from the manufacturer or its authorized service personnel in order to avoid a hazard.
- Machine must not be immersed for cleaning.

INITIAL SET-UP

CAUTION - The brewer must be disconnected from the power source throughout the initial set-up, except when specified in the instructions.

1. Insert an empty funnel into the funnel rails.
2. Place an empty decanter under the funnel.
3. Pour three pitchers of tap water into the screened area on top of the brewer. Allow approximately two minutes between pitchers for water to flow into the tank. While the third pitcher of water is entering the tank, the tank will fill to capacity and the excess will flow from the sprayhead, out of the funnel, and into the dispenser.
4. When the flow of water from the funnel stops, connect the brewer to the power source and turn on the power switch (back of brewer) and wait approximately twenty minutes for the water in the tank to heat to the proper temperature. Some water will drip from the funnel during this time; this is due to expansion and should not occur thereafter. Empty the decanter.
5. Pour one pitcher of tap water into the screened area on top of the brewer.
6. After water has stopped flowing from the funnel, allow the water in the tank to completely reheat.
7. Empty the decanter. The brewer is now ready for use in accordance with the coffee brewing instructions.

COFFEE BREWING

1. Insert a BUNN® filter into the funnel.
2. Pour the fresh coffee into the filter and level the bed of grounds by gently shaking.
3. Slide the funnel into the funnel rails.
4. Place an empty decanter beneath the funnel.
5. Pour one pitcher of tap water into the screened area on top of the brewer.
6. When brewing is completed, simply discard the grounds and filter.

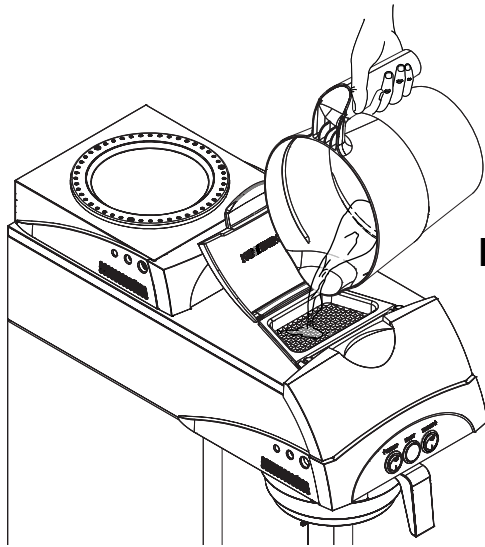

POUR IN WATER ONLY!

CLEANING

1. The use of a damp cloth rinsed in any mild, non-abrasive, liquid detergent is recommended for cleaning all surfaces on Bunn-O-Matic equipment.
2. Check and clean the sprayhead. The sprayhead holes must always remain open.
3. With the sprayhead removed, insert the deliming spring (provided) all the way into the sprayhead tube. When inserted properly, no more than two inches of spring should be visible. Push back and forth five or six times.

NOTE – In hard water areas, this may need to be done daily. It will help prevent liming problems in the brewer and takes less than a minute.

TROUBLESHOOTING

A troubleshooting guide is provided to suggest probable causes and remedies for the most likely problems encountered. If the problem remains after exhausting the troubleshooting steps, contact the Bunn-O-Matic Technical Service Department.

- Testing, and repair of electrical equipment should be performed only by qualified service personnel.
- All electronic components have 120 volt AC or low voltage DC potential on their terminals. Shorting of terminals or the application of external voltages may result in electrical shock.
- This brewer is heated at all times. Keep away from combustibles.

WARNING – • Exercise extreme caution when servicing electrical equipment.
 • Unplug the brewer when servicing.
 • Follow recommended service procedures

PROBLEM	PROBABLE CAUSE	REMEDY
Beverage overflows decanter	1. Decanter	The decanter must be completely empty before starting a brew cycle.
Weak beverage	1. Filter Type	BUNN® paper filters must be used for proper extraction.
	2. Coffee Grind	A fine or drip grind must be used for proper extraction.
	3. Sprayhead	A six-hole stainless steel sprayhead must be used for proper extraction.
	4. Funnel Loading	The BUNN® paper filter must be centered in the funnel and the bed of ground leveled by gentle shaking.
	5. Water Temperature	Place an empty funnel on an empty dispenser beneath the sprayhead. Initiate a brew cycle and check the water temperature immediately below the sprayhead with a thermometer. The reading should not be less than 195°F (91°C). Adjust the control thermostat to increase the water temperature. Replace if necessary.
Dry coffee grounds remain in the funnel	1. Funnel Loading	The BUNN® paper filter must be centered in the funnel and the bed of grounds leveled by gently shaking.

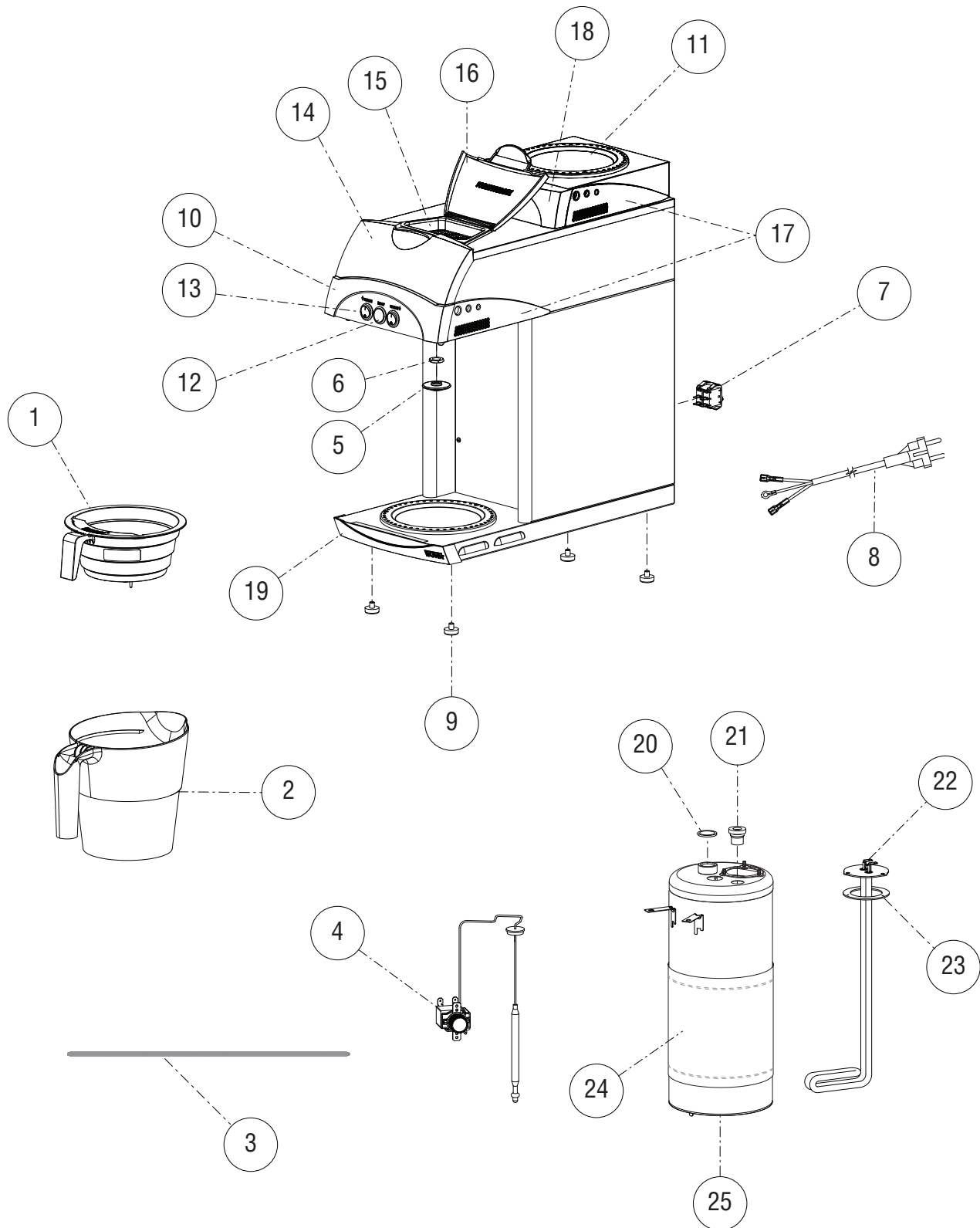

1	20583.0003	1	Funnel Assembly w/Decals
2	04238.0000	1	Pitcher
3	01188.0000	1	Delimiting Spring
4	28319.0000	1	Thermostat
	07073.1000	1	Grommet
5	01082.0000	1	Sprayhead, 6 Hole
6	01075.0000	1	Nut, Hex .438"-20
7	37381.0000	1	Switch, DPST
8	37304.0000	1	Power Cord, 120V
	37304.0001	1	Power Cord, 230V CE
	37304.0002	1	Power Cord, 230V UK
	37304.0003	1	Power Cord, 100V
9	37322.0000	4	Foot, M6 x 1.0 Thread
10	37353.0000	1	Facade, Control Panel
11	37394.0000	2	Warmer Assembly 220V
	37394.0001	2	Warmer Assembly 120V
	37394.0002	2	Warmer Assembly 100V
12	37330.0000	1	Ready Light, 220V
	37330.0001	1	Ready Light, 120V
13	37352.0000	2	Switch, Warmer
14	37346.0000	1	Upper Hood Trim
15	37351.0000	1	Lid Pour In
16	37347.0000	1	Lid
17	37333.0000	2	Side Trim, Right
	37335.0000	2	Side Trim, Left
18	37342.0000	1	Front Facade, Upper Warmer
19	37344.0000	1	Front Facade, Lower Warmer
20	01201.0000	1	Gasket, Tank Inlet
21	37376.0004	1	Grommet, Syphon Hub
22	42322.1000	1	Tank Heater, 230V
	42322.1001	1	Tank Heater, 100V
	42322.1002	1	Tank Heater, 120V
23	39590.0000	1	Gasket, Tank Heater
24	42323.0001	1	Blanket Warmer, 230V
	42323.0002	1	Blanket Warmer, 120V
25	37386.0002	1	Tank

The Following Items Are Not Illustrated

26	20151.0050	1	Filters, Pack of 50
27	37401.0000	1	Wiring Harness, Main
28	47537.0000	1	Kit, High Limit

SCHEMATIC WIRING DIAGRAM 392

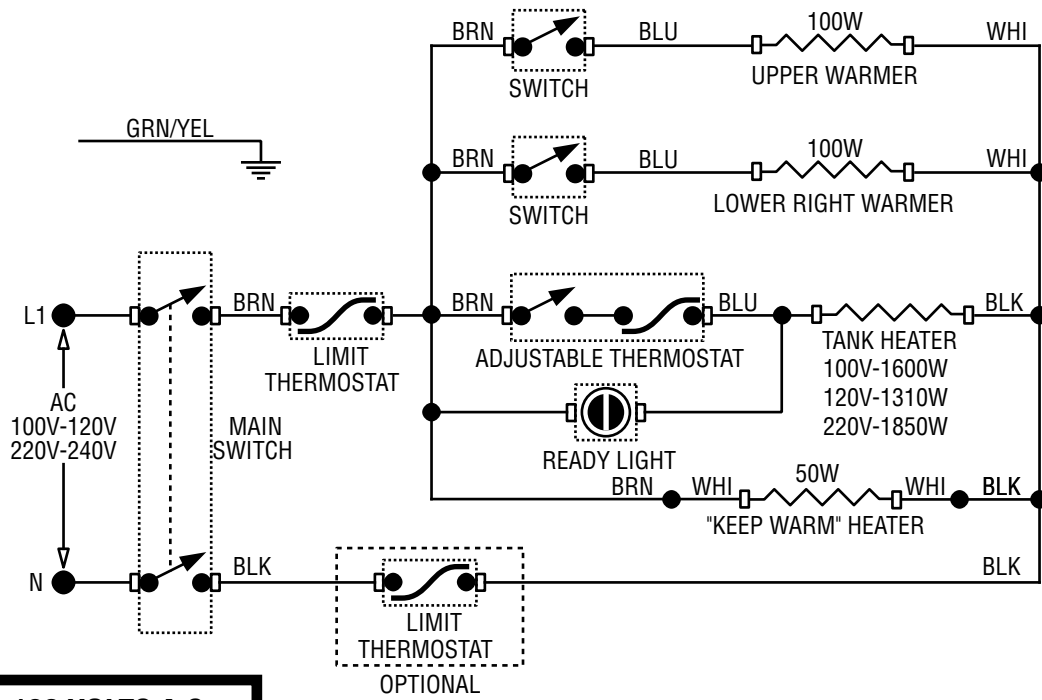

**120 VOLTS A C
2 WIRE
SINGLE PHASE
60 HZ**

39943.0000C 11/12 © 2012 BUNN-O-MATIC CORPORATION