

# BUNN®

*C, CT, CTF,  
CWT, C WTF,  
SINGLE CW,  
SINGLE CWF*

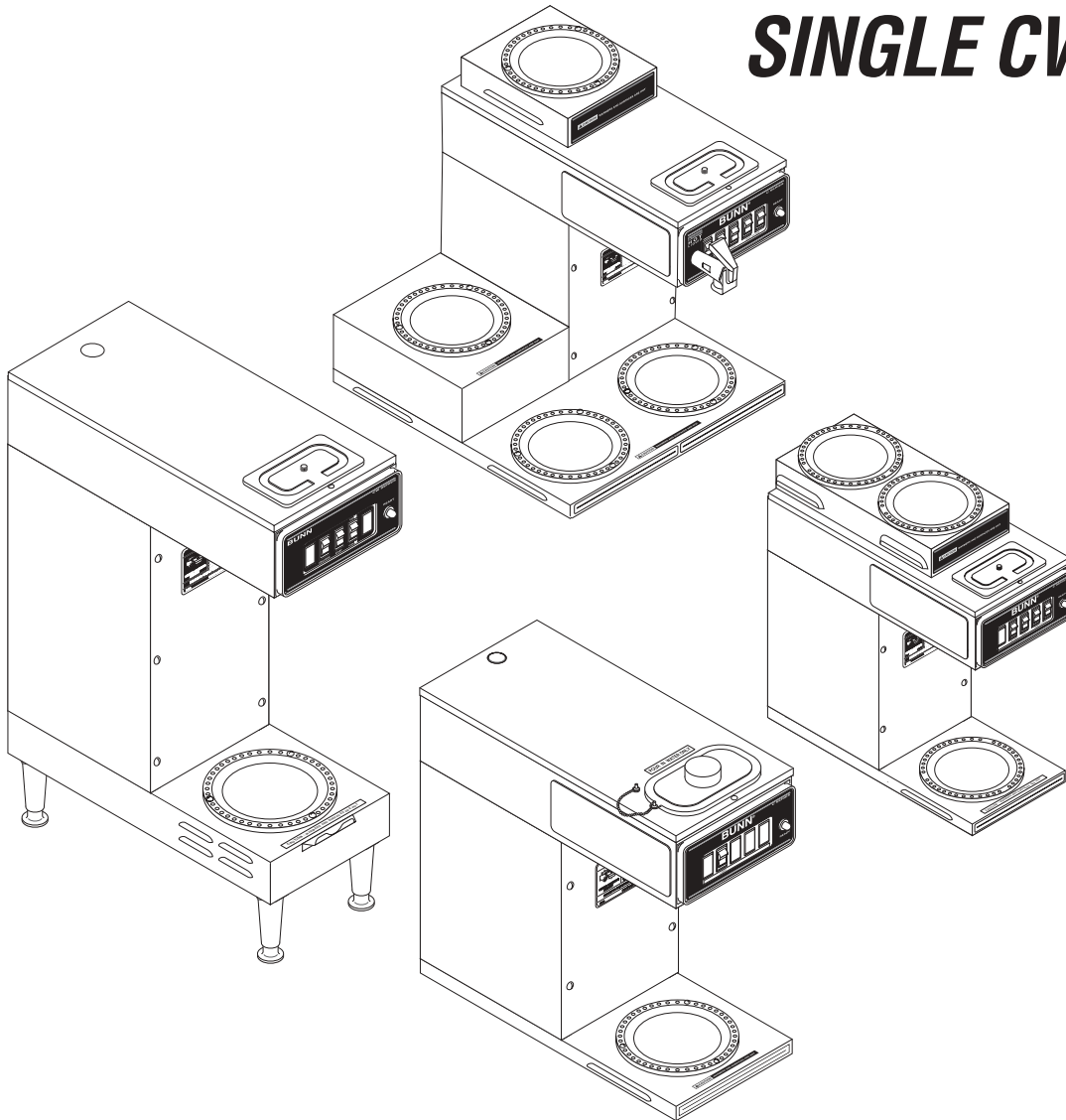

## OPERATING & SERVICE MANUAL

**BUNN-O-MATIC CORPORATION**

POST OFFICE BOX 3227

SPRINGFIELD, ILLINOIS 62708-3227

PHONE: (217) 529-6601 FAX: (217) 529-6644

## **BUNN-O-MATIC COMMERCIAL PRODUCT WARRANTY**

Bunn-O-Matic Corp. ("BUNN") warrants equipment manufactured by it as follows:

- 1) All equipment other than as specified below: 2 years parts and 1 year labor.
- 2) Electronic circuit and/or control boards: parts and labor for 3 years.
- 3) Compressors on refrigeration equipment: 5 years parts and 1 year labor.
- 4) Grinding burrs on coffee grinding equipment to grind coffee to meet original factory screen sieve analysis: parts and labor for 3 years or 30,000 pounds of coffee, whichever comes first.

These warranty periods run from the date of installation BUNN warrants that the equipment manufactured by it will be commercially free of defects in material and workmanship existing at the time of manufacture and appearing within the applicable warranty period. This warranty does not apply to any equipment, component or part that was not manufactured by BUNN or that, in BUNN's judgment, has been affected by misuse, neglect, alteration, improper installation or operation, improper maintenance or repair, damage or casualty. This warranty is conditioned on the Buyer 1) giving BUNN prompt notice of any claim to be made under this warranty by telephone at (217) 529-6601 or by writing to Post Office Box 3227, Springfield, Illinois 62708-3227; 2) if requested by BUNN, shipping the defective equipment prepaid to an authorized BUNN service location; and 3) receiving prior authorization from BUNN that the defective equipment is under warranty.

**THE FOREGOING WARRANTY IS EXCLUSIVE AND IS IN LIEU OF ANY OTHER WARRANTY, WRITTEN OR ORAL, EXPRESS OR IMPLIED, INCLUDING, BUT NOT LIMITED TO, ANY IMPLIED WARRANTY OF EITHER MERCHANTABILITY OR FITNESS FOR A PARTICULAR PURPOSE.** The agents, dealers or employees of BUNN are not authorized to make modifications to this warranty or to make additional warranties that are binding on BUNN. Accordingly, statements by such individuals, whether oral or written, do not constitute warranties and should not be relied upon.

If BUNN determines in its sole discretion that the equipment does not conform to the warranty, BUNN, at its exclusive option while the equipment is under warranty, shall either 1) provide at no charge replacement parts and/or labor (during the applicable parts and labor warranty periods specified above) to repair the defective components, provided that this repair is done by a BUNN Authorized Service Representative; or 2) shall replace the equipment or refund the purchase price for the equipment.

**THE BUYER'S REMEDY AGAINST BUNN FOR THE BREACH OF ANY OBLIGATION ARISING OUT OF THE SALE OF THIS EQUIPMENT, WHETHER DERIVED FROM WARRANTY OR OTHERWISE, SHALL BE LIMITED, AT BUNN'S SOLE OPTION AS SPECIFIED HEREIN, TO REPAIR, REPLACEMENT OR REFUND.**

In no event shall BUNN be liable for any other damage or loss, including, but not limited to, lost profits, lost sales, loss of use of equipment, claims of Buyer's customers, cost of capital, cost of down time, cost of substitute equipment, facilities or services, or any other special, incidental or consequential damages.

## USER NOTICES

Carefully read and follow all notices in this manual and on the equipment. All labels on the equipment should be kept in good condition. Replace any unreadable or damaged labels.

This equipment is to be installed to comply with the Basic Plumbing Code of the Building Officials and Code Administrators International, Inc. (BOCA) and the Food Service Sanitation Manual of the Food and Drug Administration (FDA).

#00656.0000



#00658.0000



#02763.0000



#12364.0000

## **! WARNING**

- ◆ Fill water tank before turning -on thermostat or connecting appliance to power source.
- ◆ Use only on a properly protected circuit capable of the rated load.
- ◆ Electrically ground the chassis.
- ◆ Follow national/local electrical codes.
- ◆ Do not use near combustibles.

FAILURE TO COMPLY RISKS EQUIPMENT DAMAGE, FIRE, OR SHOCK HAZARD

READ THE ENTIRE OPERATING MANUAL BEFORE BUYING OR USING THIS PRODUCT

THIS APPLIANCE IS HEATED WHENEVER CONNECTED TO A POWER SOURCE

00831.0000F 3/98 © 1988 BUNN-O-MATIC CORPORATION

#00831.0000

## ELECTRICAL REQUIREMENTS

**CAUTION** - The brewer must be disconnected from the power source until specified in *Initial Set-Up*.

**Model 15** has an attached cordset and requires 2-wire grounded service rated 120 volts ac, 15 amp, single phase, 60 Hz.

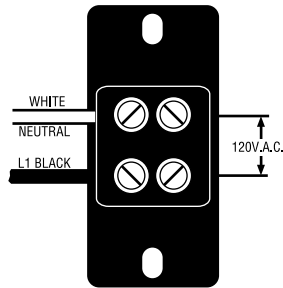

**Model 20** requires 2-wire, grounded service rated 120 volts ac, 20 amp, single phase, 60 Hz. Proceed as follows:

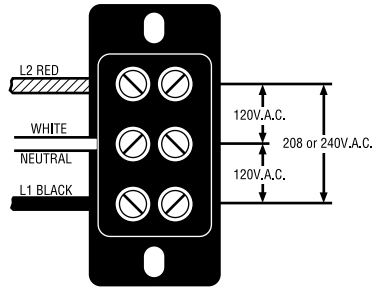

**Model 35** requires 3-wire, grounded service rated 120/208 or 120/240 volts ac, 20 amp, single phase, 60 Hz. Proceed as follows:

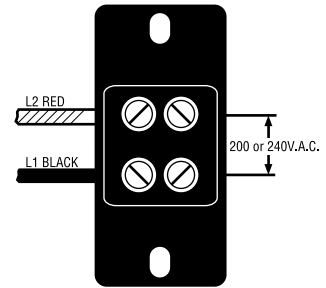

**"A" & "B"** models require 2-wire, grounded service rated 200 volts ac or 230 volts ac, 20 amp, single phase, 50 Hz. Proceed as follows:

### Electrical Hook-Up

**CAUTION** – Improper electrical installation will damage electronic components.

1. An electrician must provide electrical service as specified.
2. Using a voltmeter, check the voltage and color coding of each conductor at the electrical source.
3. Place the heater switch at the rear of the brewer in the "OFF" lower position.
4. Remove the front panel beneath the sprayhead.
5. Feed the cord through the strain relief and connect it to the terminal block.
6. Connect the brewer to the power source and verify the voltage at the terminal block before proceeding. Replace the front panel.
7. If plumbing is to be hooked-up later be sure the brewer is disconnected from the power source. If plumbing has been hooked-up, the brewer is ready for Initial Set-Up.

## PLUMBING REQUIREMENTS

### Model C:

This model is completely portable and requires no attached plumbing.

### Models CT, CTF, CWT, CWTA, CWTB, CWTF, CWTF A & CWTFB, SINGLE CW & SINGLE CWF

These brewers must be connected to a cold water system with operating pressure between 20 and 90 psi (138 to 620kPa) from a ½" or larger supply line. A shut-off valve should be installed in the line before the brewer. Install a regulator in the line when pressure is greater than 90 psi (620kPa) to reduce it to 50 psi (345kPa). The water inlet fitting is ¼" flare.

**NOTE** - Bunn-O-Matic recommends ¼" copper tubing for installations of less than 25 feet and ⅜" for more than 25 feet from the ½" water supply line. A tight coil of copper tubing in the water line will facilitate moving the brewer to clean the countertop. Bunn-O-Matic does not recommend the use of a saddle valve to install the brewer. The size and shape of the hole made in the supply line by this type of device may restrict water flow.

**This equipment must be installed to comply with the Basic Plumbing Code of the Building Officials and Code Administrators International, Inc. (BOCA) and the Food Service Sanitation Manual of the Food and Drug Administration (FDA).**

## PLUMBING REQUIREMENTS (cont.)

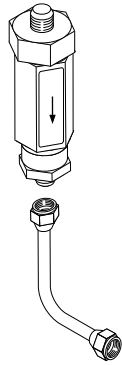

MODELS W/OUT FAUCET

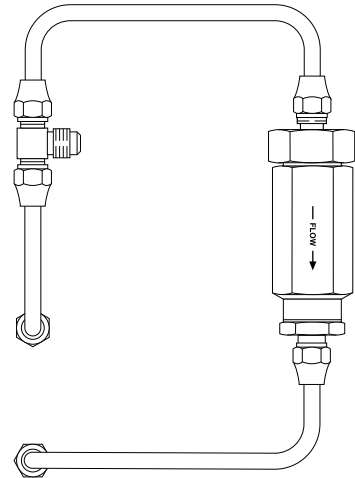

MODELS W/FAUCET

### **Models CT, CWT, CTF, CWTF, SINGLE CW & SINGLE CWF**

1. Flush the water line and securely attach it to the flare fitting on the strainer or tee.
2. Turn on the water supply.
3. On CTF, CWTF and SINGLE CWF Models, place an empty vessel beneath the faucet and lift the handle until water is dispensed.

## INITIAL SET-UP

**CAUTION** - The brewer must be disconnected from the power source throughout the initial set-up, except when specified in the instructions.

1. Insert an empty funnel into the funnel rails.
2. Place an empty dispenser under the funnel.
3. Place the heater switch at the rear of the brewer in the "OFF" lower position and connect the brewer to the power source.
4. Fill the tank with water as directed:
  - 4A. **Model C**  
Pour three pitchers of tap water into the screened area on top of the brewer. Allow approximately two minutes between pitchers for water to flow into the tank. While the third pitcher of water is entering the tank, the tank will fill to capacity and the excess will flow from the sprayhead, out of the funnel, and into the dispenser.
  - 4B. **Models CT, CTF, CWT, CWTA, CWTB, CWTF, CWTF A, CWTFB, SINGLE CW & SINGLE CWF**  
Connect the brewer to the power source, place the "ON/OFF" switch in the "ON" upper position, and momentarily press and release the start switch. Water will begin flowing into the tank. When water stops flowing into the tank, initiate a second and a third brew cycle. During the third brew cycle the tank will fill to its capacity and the excess will flow from the sprayhead, out of the funnel, and into the dispenser.
5. When the flow of water from the funnel stops, place the heater switch at the rear of the brewer in the "ON" upper position and wait approximately twenty minutes for the water in the tank to heat to the proper temperature. Some water will drip from the funnel during this time; this is due to expansion and should not occur thereafter.
6. Empty the dispenser and initiate another brew cycle as directed:
  - 6A. **Model C**  
Pour one pitcher of tap water into the screened area on top of the brewer.
  - 6B. **Models CT, CTF, CWT, CWTA, CWTB, CWTF, CWTF A, CWTFB, SINGLE CW & SINGLE CWF**  
Place the "ON/OFF" switch in the "ON" upper position, and on models SINGLE CW and SINGLE CWF place the batch selector switch in the "1 GAL" position. Momentarily press and release the start switch.
7. Place the "ON/OFF" switch in the lower "OFF" position after water has stopped flowing from the funnel, and let the water in the tank reheat to the proper temperature.
8. Empty the dispenser; place the "ON/OFF" switch in the "ON" upper position, and momentarily press and release the start switch. Check the water volume in the dispenser after water has stopped flowing from the funnel. It should be 64 ounces for all models except SINGLE CW and SINGLE CWF should be 128 ounces.
9. Models SINGLE CW and SINGLE CWF only, place the batch selector switch in the "1/2 GAL" position, and momentarily press and release the start switch. Check the water volume in the dispenser after water has stopped flowing from the funnel. It should be 64 ounces.
10. If water volumes are not correct, adjust the brew timer as required. See *Adjusting Brew Volumes*. Allow the water to reheat, start, and measure another brew cycle.
11. Repeat step 10 until correct water volume is achieved.

The brewer is now ready for use in accordance with the coffee brewing instructions on the next page.

## ADJUSTING BREW VOLUMES

**CAUTION** - Disconnect the power source from the brewer prior to the removal of any panel for the replacement or adjustment of any component.

**NOTE:** Prior to setting or modifying batch sizes, check that the brewer is connected to water supply, the tank is properly filled, and a funnel and server are in place.

1. **Modifying batch sizes.** To modify a batch volume, first check that the SET/LOCK switch is in the "SET" position on the circuit board.

**To increase a batch size.** Press and hold the START or BREW switch until three clicks are heard. Release the switch (Failure to release the switch within two seconds after the third click causes the volume setting to be aborted and previous volume setting will remain in memory) and press it again one or more times. Each time the switch is pressed, two seconds are added to the brew time period. Allow the brew cycle to finish in order to verify that the desired volume has been achieved.

**To decrease a batch size.** Press and release the START or BREW switch once for every two-second interval to be removed from the total brew time period; then immediately press and hold down the START or BREW switch until three clicks are heard. Release the switch. (Failure to release the switch within two seconds after the third click causes the volume setting to be aborted and previous volume setting will remain in memory). Allow the brew cycle to finish in order to verify that the desired volume has been achieved.

## OPERATING CONTROLS

### Model C

#### ON/OFF SWITCH

Placing the "ON/OFF" switch in the "ON" upper position supplies power to the brew station warmer.

### Models CT, CTF, CWT, CWTA, CWTB, CWTF, CWTF A, CWTFB, SINGLE CW & SINGLE CWF

#### ON/OFF SWITCH

Placing the "ON/OFF" switch in the "OFF" lower position stops brewing. Stopping a brew cycle after it has been started will not stop the flow of water into the funnel until the tank syphons down to its proper level. Placing the switch in the "ON" upper position supplies power to the brew station warmer and enables the brew circuit.

#### START SWITCH

Momentarily pressing and releasing the switch starts a brew cycle when the "ON/OFF" switch is in the "ON" upper position.

**NOTE** – The "ON/OFF" switch must be in the "ON" upper position to initiate and complete a brew cycle.

## COFFEE BREWING

1. Insert a BUNN® filter into the funnel.
2. Pour the fresh coffee into the filter and level the bed of grounds by gently shaking.
3. Slide the funnel into the funnel rails.
4. Place an empty dispenser beneath the funnel.
5. Operate the brewer as directed:

#### 5A. Model C

Pour one pitcher of tap water into the screened area on top of the brewer.

#### 5B. Models CT, CTF, CWT, CWTA, CWTB, CWTF, CWTF A, CWTFB, SINGLE CW & SINGLE CWF

Place the "ON/OFF" switch in the "ON" upper position. Momentarily press and release the start switch.

6. When brewing is completed, simply discard the grounds and filter.

## CLEANING

1. The use of a damp cloth rinsed in any mild, non-abrasive, liquid detergent is recommended for cleaning all surfaces on Bunn-O-Matic equipment.
2. Check and clean the sprayhead. The sprayhead holes must always remain open.
3. With the sprayhead removed, insert the delimiting spring (provided) all the way into the sprayhead tube. When inserted properly, no more than two inches of spring should be visible. Saw back and forth five or six times.

**NOTE** – In hard water areas, this may need to be done daily. It will help prevent liming problems in the brewer and takes less than a minute.

## TROUBLESHOOTING

A troubleshooting guide is provided to suggest probable causes and remedies for the most likely problems encountered. If the problem remains after exhausting the troubleshooting steps, contact the Bunn-O-Matic Technical Service Department.

- Inspection, testing, and repair of electrical equipment should be performed only by qualified service personnel.
- All electronic components have 120 volt ac and low voltage dc potential on their terminals. Shorting of terminals or the application of external voltages may result in board failure.
- Intermittent operation of electronic circuit boards is unlikely. Board failure will normally be permanent. If an intermittent condition is encountered, the cause will likely be a switch contact or a loose connection at a terminal or crimp.
- Solenoid removal requires interrupting the water supply to the valve. Damage may result if solenoids are energized for more than ten minutes without a supply of water.
- The use of two wrenches is recommended whenever plumbing fittings are tightened or loosened. This will help to avoid twists and kinks in the tubing.
- Make certain that all plumbing connections are sealed and electrical connections tight and isolated.
- This brewer is heated at all times. Keep away from combustibles.

- WARNING** –
- Exercise extreme caution when servicing electrical equipment.
  - Unplug the brewer when servicing, except when electrical tests are specified.
  - Follow recommended service procedures
  - Replace all protective shields or safety notices

PROBLEM	PROBABLE CAUSE	REMEDY
Brew cycle will not start (CT, CTF, CWT, CWTA, CWTB, CWTF, CWTFB, SINGLE CW & SINGLE CWF)	1. No water  2. No power or incorrect voltage to the brewer	Water lines and valves to the brewer must be open.  (A1) Check the terminal block for 120 volts across the black and white terminals on two wire 120 volt brewers. (A2) Check the terminal block for 120 volts across the red and white terminals and the black and white terminals on three wire 120/240 volt brewers. (A3) Check the terminal block for 200 volts on "B Series" brewers or 230 volts on "A Series" brewers across the red and black terminals.  (B) Check circuit breakers or fuses.



## TROUBLESHOOTING (cont.)

### PROBLEM

### PROBABLE CAUSE

### REMEDY

Brew cycle will not start (cont.)  
(CT, CTF, CWT, CWTA, CWTB,  
CWTF, CWTFA, CWTFB, SINGLE  
CW & SINGLE CWF)

3. ON/OFF Switch

Refer to *Service* - ON/OFF Switch for testing. See page 17

4. Start Switch

Refer to *Service* - Start Switch for testing procedures. See page 20

5. Timer

Refer to *Service* - Timer for testing procedures. See page 24

6. Solenoid Valve

Refer to *Service* - Solenoid Valve for testing procedures. See page 19

7. Water strainer/flow control  
(.222 GPM)

(A) Direction of flow arrow must be pointing towards brewer.

(B) Remove the strainer/flow control and check for obstructions. Clear or replace.

Water is not hot

1. Tank Heater Switch

Refer to *Service* - Tank Heater Switch for testing procedures. See page 22

2. Limit Thermostat

**CAUTION** - Do not eliminate or bypass limit thermostat. Use BOM replacement part #29329.1000

Refer to *Service* - Limit Thermostat for testing procedures. See page 16

3. Control Thermostat

Refer to *Service* - Control Thermostat for testing procedures. See page 15

4. Tank Heater

Refer to *Service* - Tank Heater for testing procedures. See page 21

## TROUBLESHOOTING (cont.)

### PROBLEM

Inconsistent beverage level in dispenser

### PROBABLE CAUSE

1. Strainer/flow control (.222 GPM) (CT,CTF, CWT, CWTA, CWTB, CWTF, CWTFa, CWTFB, SINGLE CW & SINGLE CWF)

### REMEDY

(A) Direction of flow arrow must be pointing towards the brewer.

(B) Remove the strainer/flow control and check for obstruction. Clear or replace.

2. Syphon System

The brewer must be level or slightly lower in front to syphon properly.

3. Lime Build-up

**CAUTION** - Tank and tank components should be delimed regularly depending on local water conditions. Excessive mineral build-up on stainless steel surfaces can initiate corrosive reactions resulting in serious leaks.

Inspect the tank assembly for excessive lime deposits. Delime as required.

4. Water Pressure (CT, CTF, CWT, CWTA, CWTB, CWTF, CWTFa, CWTFB, SINGLE CW & SINGLE CWF)

The water pressure to the brewer must be at least 20 psi (138 kPa).

Consistently low beverage level in the dispenser (CT, CTF, CWT, CWTA, CWTB, CWTF, CWTFa, CWTFB, SINGLE CW & SINGLE CWF)

1. Timer

(Early models) Timer dial must indicate at least two minutes and fifteen seconds.

2. Strainer/flow Control (.222 GPM)

(A) Direction of flow arrow must be pointing towards brewer.

(B) Remove the strainer/flow control and check for obstructions. Clear or replace.

Spitting or excessive steaming

1. Lime Build-up

**CAUTION** - Tank and tank components should be delimed regularly depending on local water conditions. Excessive mineral build-up on stainless steel surfaces can initiate corrosive reactions resulting in serious leaks.

Inspect tank assembly for excessive lime deposits. Delime as required.

## TROUBLESHOOTING (cont.)

### PROBLEM

### PROBABLE CAUSE

### REMEDY

Spitting or excessive steaming (cont.)

2. Control Thermostat

Refer to *Service* - Control Thermostat for testing procedures. See page 15

Dripping from sprayhead

1. Syphon System

The brewer must be level or slightly lower in front to syphon properly.

2. Lime Build-up

**CAUTION** - Tank and tank components should be delimed regularly depending on local water conditions. Excessive mineral build-up on stainless steel surfaces can initiate corrosive reactions resulting in serious leaks.

Inspect the tank assembly for excessive lime deposits. Delime as required.

3. Solenoid Valve (CT, CTF, CWT, CWTA, CWTB, CWTF, CWTFB, SINGLE CW & SINGLE CWF)

Remove the solenoid valve and clear any obstructions. Rebuild or replace the valve if necessary. See page 19

Water flows into tank continuously (ON/OFF Switch "ON")

1. Timer (CT, CTF, CWT, CWTA, CWTB, CWTF, CWTFB, SINGLE CW & SINGLE CWF)

Refer to *Service* - Timer for testing procedures. See page 24

Water flows into tank continuously (ON/OFF Switch "OFF")

1. Solenoid Valve (CT, CTF, CWT, CWTA, CWTB, CWTF, CWTFB, SINGLE CW & SINGLE CWF)

Remove the Solenoid Valve and clean any obstruction. Rebuild or replace the valve if necessary. See page 19

Beverage overflows dispenser

1. Dispenser

The dispenser must be completely empty before starting a brew cycle.

2. Timer (CT, CTF, CWT, CWTA, CWTB, CWTF, CWTFB, SINGLE CW & SINGLE CWF)

Refer to *Service* - Timer for testing procedures. See page 24

3. Solenoid Valve (CT, CTF, CWT, CWTA, CWTB, CWTF, CWTFB, SINGLE CW & SINGLE CWF)

Remove the Solenoid Valve and clean any obstruction. Rebuild or replace the valve if necessary. See page 19

## TROUBLESHOOTING (cont.)

### PROBLEM

### PROBABLE CAUSE

### REMEDY

Weak beverage

1. Filter Type

BUNN® paper filters must be used for proper extraction.

2. Coffee Grind

A fine or drip grind must be used for proper extraction.

3. Sprayhead

A clean spray-head must be used for proper extraction.

4. Funnel Loading

The BUNN® paper filter must be centered in the funnel and the bed of ground leveled by gentle shaking.

5. Water Temperature

Place an empty funnel on an empty dispenser beneath the sprayhead. Initiate a brew cycle and check the water temperature immediately below the sprayhead with a thermometer. The reading should not be less than 195°F (76°C). Adjust the control thermostat to increase the water temperature. Replace if necessary.

Dry coffee grounds remain in the funnel

1. Funnel Loading

The BUNN® paper filter must be centered in the funnel and the bed of grounds leveled by gently shaking.

Brewer is making unusual noises (CT, CTF, CWT, CWTA, CWTB, CWTF, CWTFB, SINGLE CW & SINGLE CWF)

1. Solenoid

The nut on the solenoid must be tight or it will vibrate during operation.

2. Plumbing Lines

Plumbing lines should not resting on the counter top.

3. Water Supply

(A) The brewer must be connected to a cold water line.

(B) Water pressure to the brewer must not exceed 90 psi (620 kPa). Install a regulator if necessary to lower the working pressure to approximately 50 psi (345 kPa).

## TROUBLESHOOTING (cont.)

<b>PROBLEM</b>	<b>PROBABLE CAUSE</b>	<b>REMEDY</b>
Brewer is making unusual noises (cont.)(CT, CTF, CWT, CWTA, CWTB, CWTF, CWTFB, CWTFB, SINGLE CW & SINGLE CWF)	4. Tank Heater	Remove and clean lime off the tank heater. See page 21
Brewer is making unusual noises (C)	1. Tank Heater	Remove and clean lime off the tank heater. See page 21
Low beverage serving temperature	1. Warmer	Refer to <i>Service</i> - Warmer element for testing procedures. See page 27
Brewer does not change volume when half/full switch is changed.	1. Selector switch	Refer to <i>Service</i> - Selector switch testing procedures. See page 20

## SERVICE

This section provides procedures for testing and replacing various major components used in this brewer should service become necessary. Refer to *Troubleshooting* for assistance in determining the cause of any problem.

**WARNING** - Inspection, testing, and repair of electrical equipment should be performed only by qualified service personnel. The brewer should be unplugged when servicing, except when electrical tests are required and the test procedure specifically states to plug-in the brewer.

### COMPONENT ACCESS

**WARNING** - Disconnect the brewer from the power source before the removal of any panel or the replacement of any component.

All components are accessible by the removal of the top cover, front inspection panel and warmer plate(s).

The top cover is attached with one #4-40 screw.

The front inspection panel is attached with #6-32 screws.

The warmer assembly is attached with three #4-40 screws.

### Contents

Control Thermostat .....	15
Limit Thermostat .....	16
ON/OFF Switch .....	17
Solenoid (Inlet) .....	19
Start Switch (Brew) .....	20
Selector Switch .....	20
Tank Heater .....	21
Tank Heater Switch .....	22
Timer .....	24
Warmer Element .....	27
Wiring Diagrams .....	28, 29, 30, 31, 32 & 33

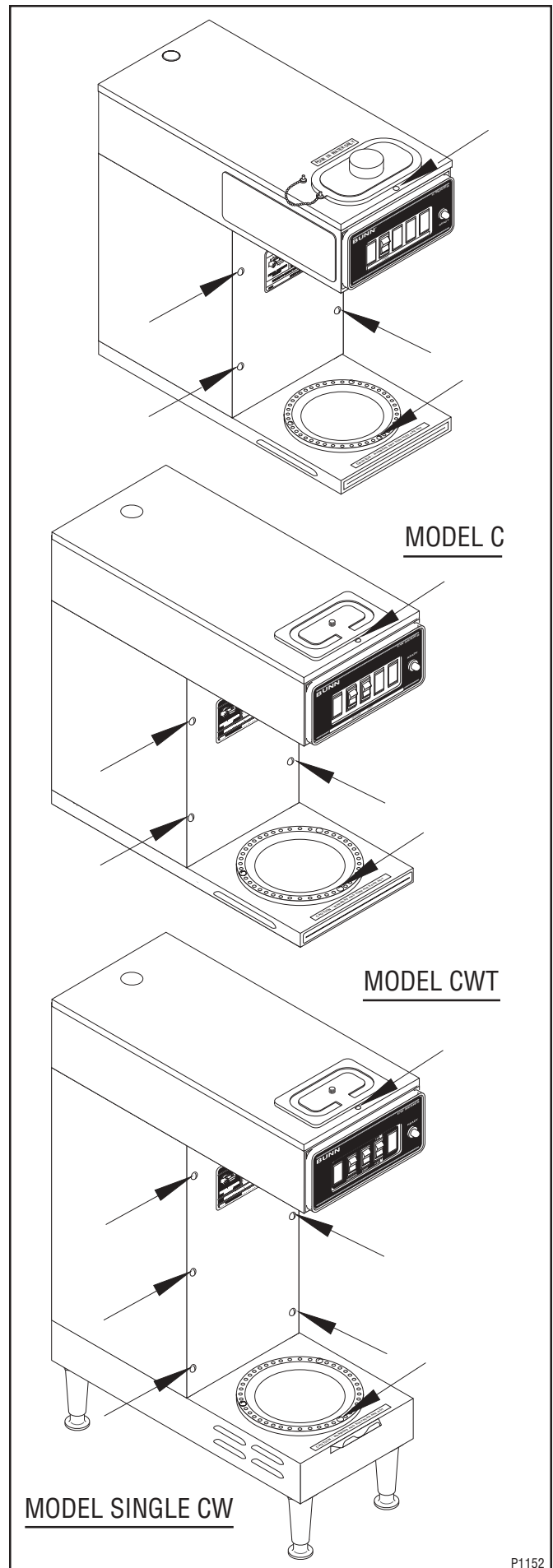

## SERVICE (cont.)

### CONTROL THERMOSTAT

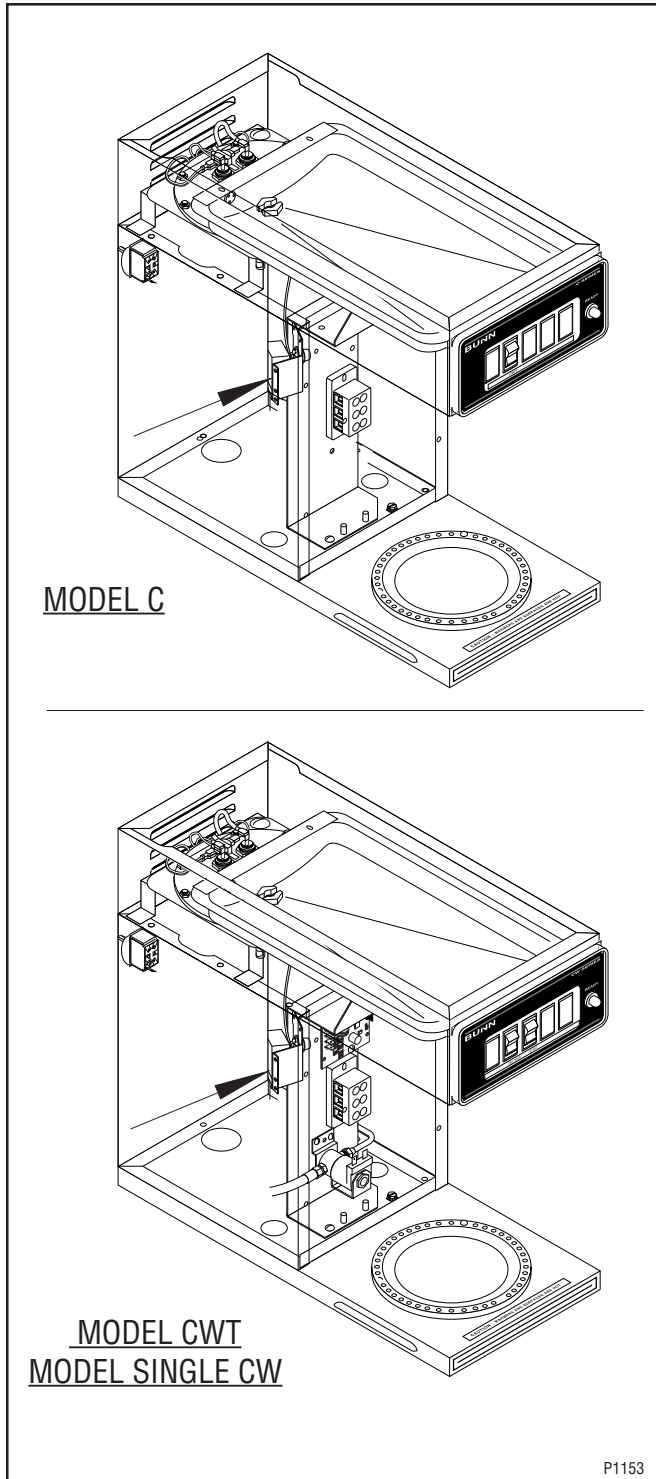

#### Location:

The control thermostat is located inside the trunk on the left side of the component bracket.

#### Test Procedures:

1. Disconnect the brewer from the power source.
2. Locate the blue wire on the control thermostat.

3. Check the voltage across the blue wire on the control thermostat and the white insert on two pole 120 volt terminal block or three pole 120/240 volt terminal blocks and the red insert on two wire 200 volt or 240 volt terminal block with a voltmeter. Connect the brewer to the power source. The indication must be:
  - a) 120 volts ac for two wire 120 volt models and three wire 120/240 volt models.
  - b) 200 to 230 volts ac for two wire 200 volt or 230 volt models.
4. Disconnect the brewer from the power source.

If voltage is present as described, proceed to #5. If voltage is not present as described, refer to the wiring diagrams and check the brewer wiring harness.

5. Locate the black wire on the control thermostat.
6. Gently remove the capillary bulb and grommet from the tank.
7. Check the voltage across the black wire of the control thermostat and the white insert on the two pole 120 volt or three pole 120/240 volt terminal block and the red insert on the two pole 200 volt or 230 volt terminal block with a voltmeter when the control thermostat is turned fully clockwise. Connect the brewer to the power source. The indication must be:
  - a) 120 volts ac for two wire 120 volt models and three wire 120/240 volt models.
  - b) 200 to 230 volts ac for two wire 200 volt or 230 volt models.
8. Disconnect the brewer from the power source.

If voltage is present as described, reinstall the capillary tube into the tank to the line 4.5" (6.0" for Single CW models) above the bulb, the control thermostat is operating properly.

If voltage is not present as described, replace the thermostat.

#### Removal and Replacement:

1. Remove wires from control thermostat leads.
2. Remove the thermostat capillary bulb by firmly pulling-up on the capillary at the tank lid. This will disengage the grommet from the tank lid.
3. Remove the one #8-32 screw securing the control thermostat to the component bracket in the trunk.

## SERVICE (cont.)

### CONTROL THERMOSTAT (cont.)

4. Slide the grommet to the line 4.5" above the bulb on the new capillary tube.
5. Insert the capillary bulb through the hole in the tank lid and press the grommet firmly and evenly so that the groove in the grommet fits into the tank lid.
6. Carefully bend the capillary tube so that the tube and bulb inside the tank are in the vertical position.

**NOTE** - The capillary tube must be clear of any electrical termination and not kinked.

7. Early Models: Using two #8-32 screws secure the control thermostat inside the hood.  
Late Models. Using one #8-32 screw secure the control thermostat to the component bracket inside the trunk.
8. Refer to the illustration below when reconnecting the wires.
9. Adjust the control thermostat as required.

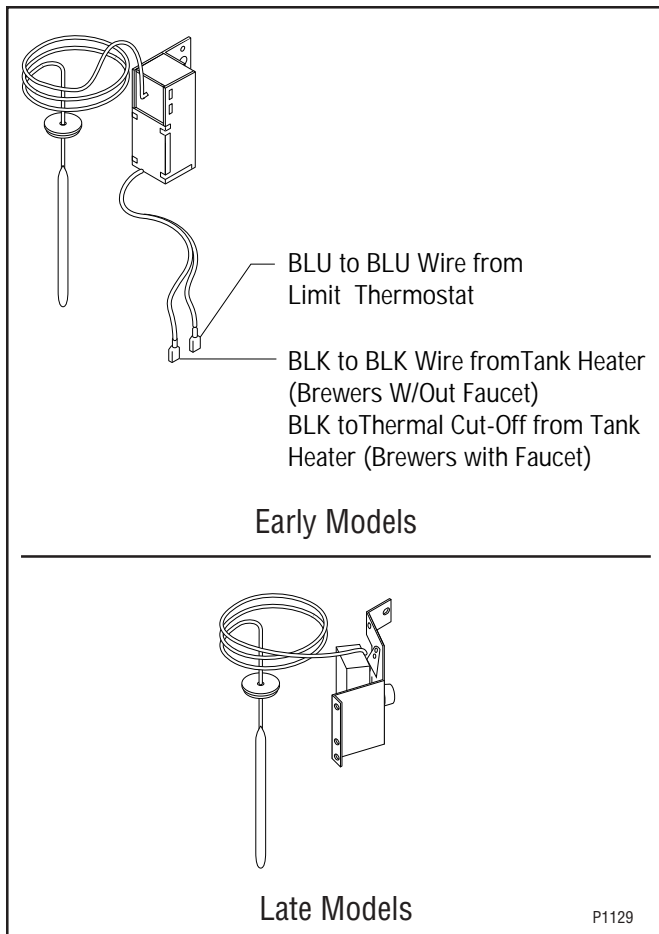

### LIMIT THERMOSTAT

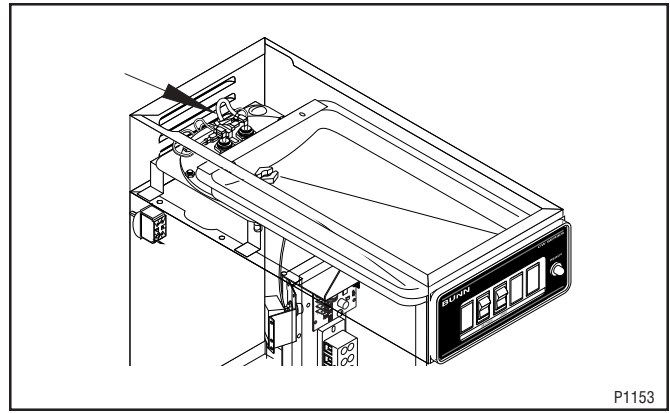

#### Location:

The limit thermostat is located inside the rear of the hood on the tank lid.

#### Test Procedures:

1. Disconnect the brewer from the power source.
2. Disconnect the blue and black wires from the limit thermostat.
3. Check for continuity across the limit thermostat terminals with an ohmmeter.

If continuity is present as described, the limit thermostat is operating properly.

If continuity is not present as described, replace the limit thermostat.

#### Removal and Replacement:

1. Remove all wires from limit thermostat terminals.
2. Carefully slide the limit thermostat out from under the retaining clip and remove limit thermostat.
3. Carefully slide the new limit thermostat into the retaining clip.
4. Refer to the illustration below when reconnecting the wires.

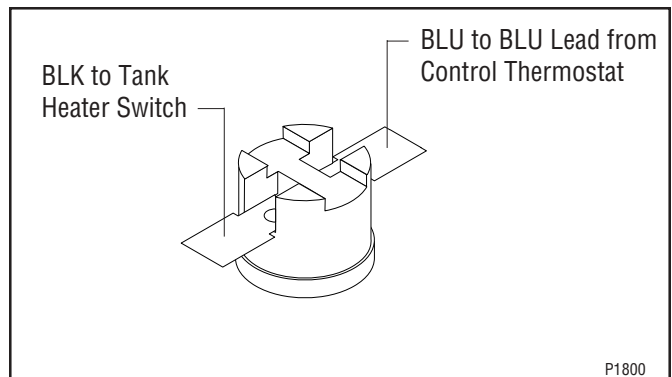



**SERVICE (cont.)**  
**ON/OFF SWITCH - MODEL C**

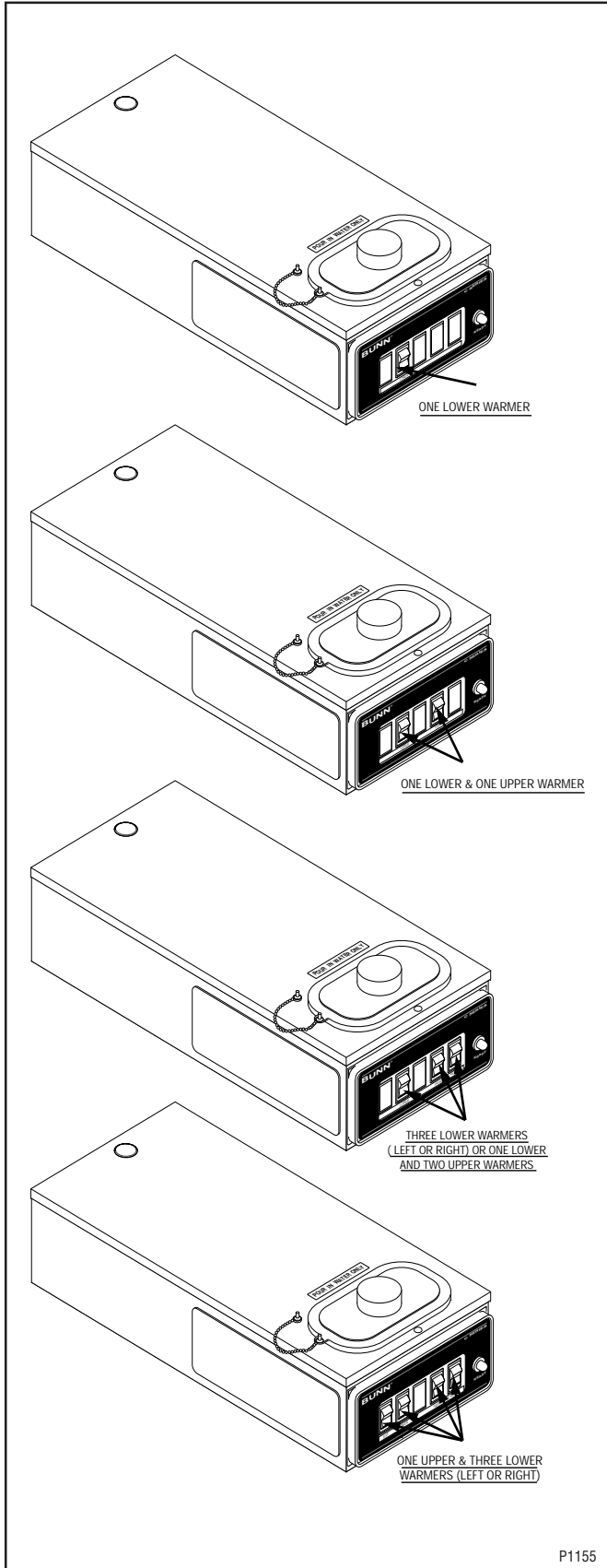

**ON/OFF SWITCH - MODEL CWT & SINGLE CW**

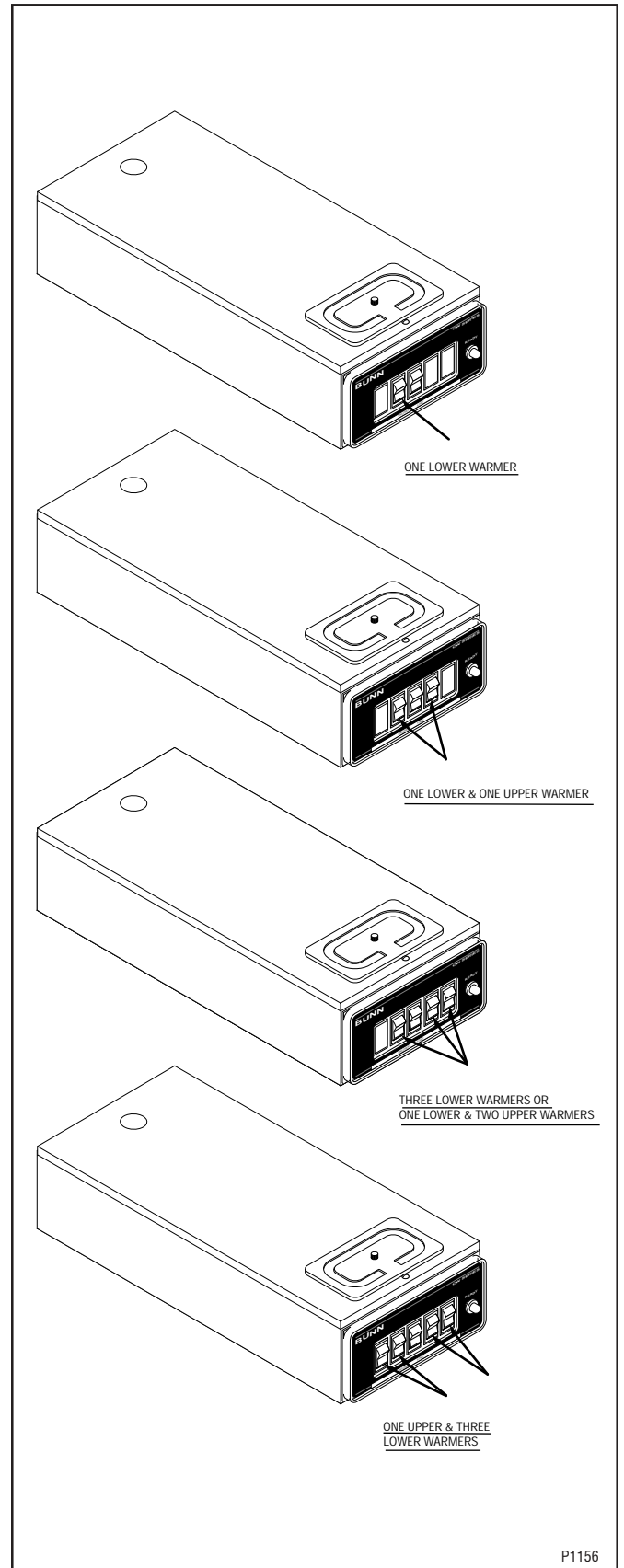

**Location:**

The ON/OFF switch(s) are located on the front of the hood.

## SERVICE (cont.)

### ON/OFF SWITCH (cont.)

#### Test Procedure:

1. Disconnect the brewer from the power source.
2. Viewing the switch from the back remove the white or red wire from the upper terminal and the black wire from the center terminal.
3. Check the voltage across the white wire or red wire and the black wire with a voltmeter. Connect the brewer to the power source. The indication must be:
  - a) 120 volts ac for two wire 120 volt models and three wire 120/240 volt models.
  - b) 200 to 230 volts ac for two wire 200 or 230 volt models.
4. Disconnect the brewer from the power source.

If voltage is present as described, reconnect the white or red wire and proceed to #5.

If voltage is not present as described, refer to the *Wiring Diagrams* and check the brewer wiring harness.

5. With the black wire removed, remove the wire from the lower terminal.
6. Check for continuity across the center and lower terminal with the switch in the "ON" position. Continuity must not be present when the switch is in the "OFF" position.

If continuity is present as described, reconnect the black wire to the center terminal and the wire to the lower terminal.

If continuity is not present as described, replace the switch.

#### Removal and Replacement:

1. Remove the wires from the switch terminals.
2. Compress the clips inside the hood and gently push the switch through the opening.
3. Push the new switch into the opening and spread the clips to hold switch in the hood.
4. Refer to the following illustration when reconnecting the wires.

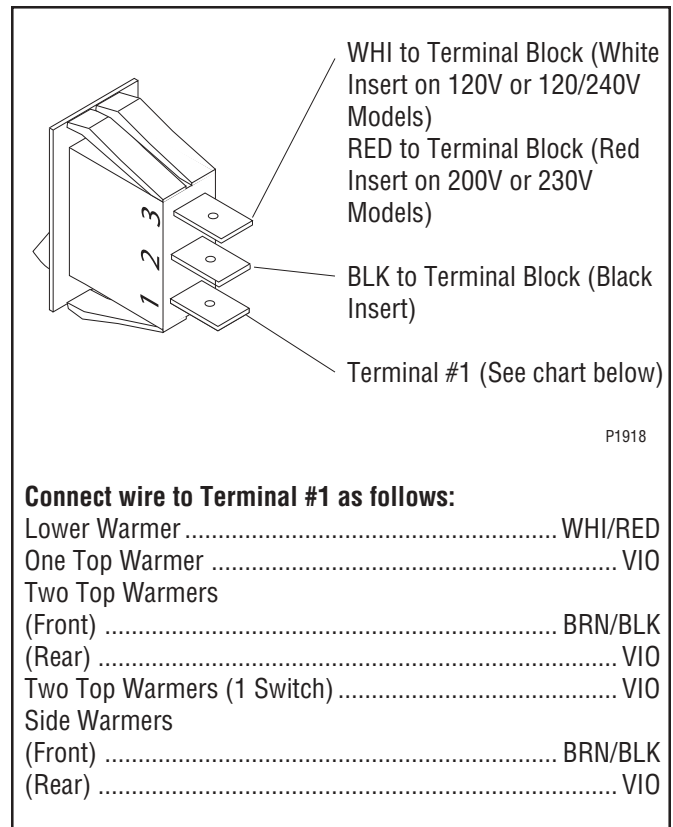

## SERVICE (cont.)

### SOLENOID VALVE - CT, CWT & SINGLE CW

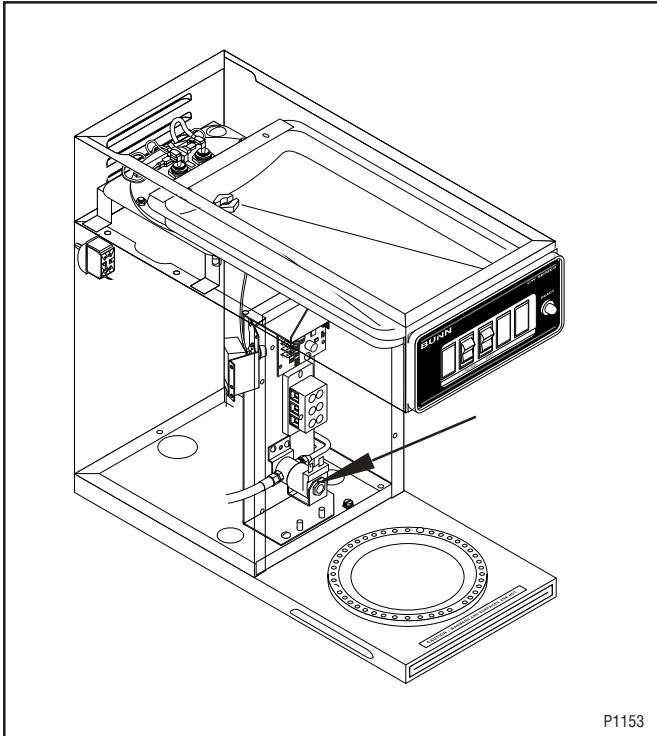

#### Location:

The solenoid valve is located inside the trunk on the lower center part of the component bracket.

#### Test Procedures:

1. Disconnect the brewer from the power source.
2. Disconnect the white/blue and white/green wires from the solenoid valve. With the "ON/OFF" switch in the "ON" upper position press the start switch.
3. Check the voltage across the white/blue and white/green wires with a voltmeter. Connect brewer to power source. The indication must be:
  - a) 120 volts ac for two wire 120 volt models and three wire 120/240 volt models.
  - b) 200 to 230 volts ac for two wire 200 or 230 volt models.
4. Disconnect brewer from the power source,

If voltage is present as described, proceed to #5  
If voltage is not present as described, refer to *Wiring Diagrams* and check brewer wiring harness.

5. Check for continuity across the solenoid valve coil terminals.

If continuity is present as described, reconnect the white/blue and white/green wire from the timer.  
If continuity is not present as described, replace the

solenoid valve.

6. Check the solenoid valve for coil action. Connect the brewer to the power source. With "ON/OFF" switch in the "ON" upper position press start switch and listen carefully in the vicinity of the solenoid valve for a "clicking" sound as the coil magnet attracts.
7. Disconnect the brewer from the power source.

If the sound is heard as described and water will not pass through the solenoid valve, there may be a blockage in the water line before the solenoid valve or, the solenoid valve may require inspection for wear, and removal of waterborne particles.

If the sound is not heard as described, replace the solenoid valve.

#### Removal and Replacement:

1. Remove the white/blue and white/green from the solenoid valve.
2. Turn-off the water supply to the brewer.
3. Disconnect the water lines to and from the solenoid valve.
4. Remove the two #8-32 screws securing the solenoid mounting bracket to the component bracket. Remove solenoid bracket and solenoid valve as an assembly.
5. Remove the two #10-32 screws and lockwashers securing the solenoid valve to the solenoid bracket.
6. Using two #10-32 screws and lockwashers install new solenoid valve on solenoid mounting bracket.
7. Using two #8-32 screws install solenoid valve and bracket to the component bracket.
8. Securely fasten the water lines to and from the solenoid valve.
9. Refer to the illustration below when reconnecting the wires.

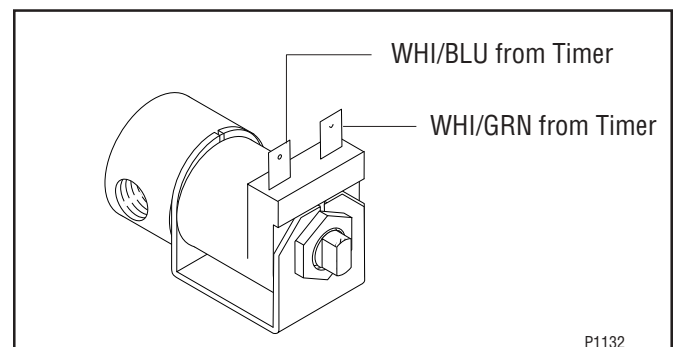

**SERVICE (cont.)**  
**SELECTOR SWITCH - SINGLE CW only**

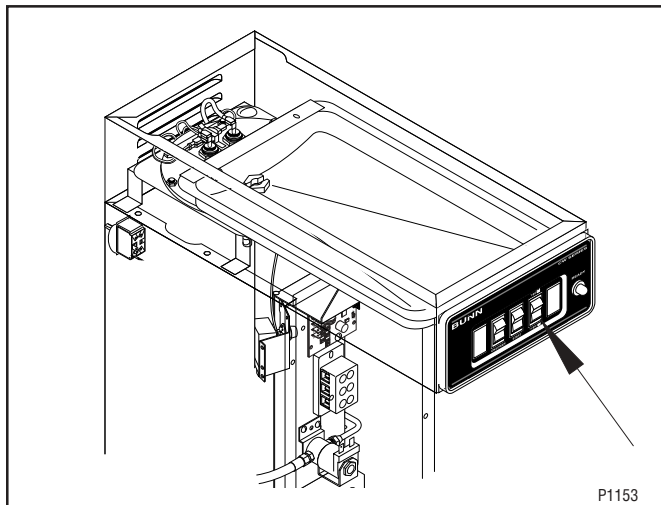

Location:

The batch selector switch is located on the front of the hood to the right of the start switch.

Test Procedure:

1. Disconnect the brewer from the power supply.
2. Disconnect the pink and tan wires from the switch terminals.
3. Check for continuity across the two terminals on the switch when it is in the both positions. Continuity must be present across these terminals only in the full position.

If continuity is not present as described, replace the switch.

Removal and Replacement:

1. Remove the pink and tan wires from the switch.
2. Compress the clips inside the hood and gently push the switch through the opening.
3. Push new switch into the opening and spread the clips to hold the switch in the hood.
4. Refer to the following illustration when reconnecting the wires.

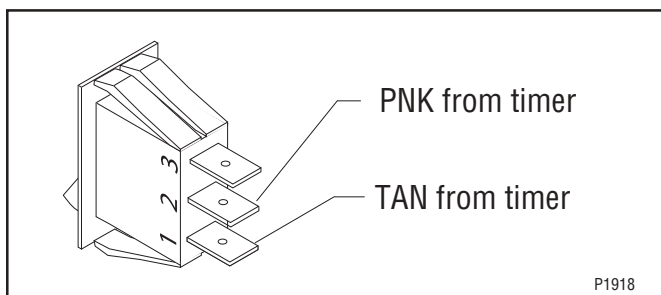

**START SWITCH - CT, CWT & SINGLE CW**

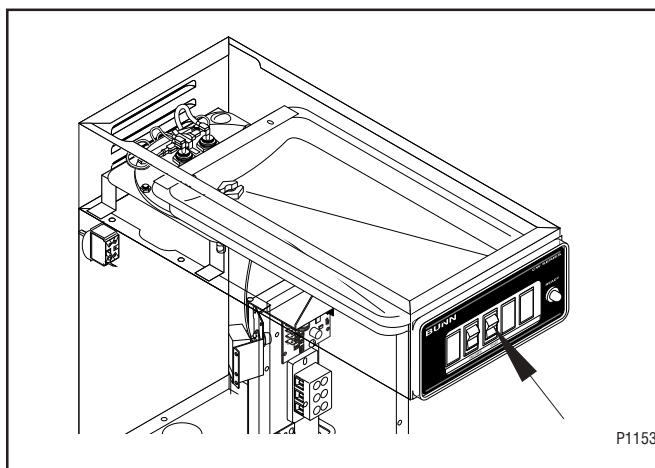

Location:

The start switch is located in the center front of the hood.

Test Procedure:

1. Disconnect the brewer from the power supply.
2. Disconnect the blue wire from the top switch terminal and the white/red from the bottom switch terminal.
3. Check for continuity across the two terminals on the switch when it is held in the lower position. Continuity must not be present across these terminals in the upper position.

If continuity is present as described, reconnect the blue wire to the top terminal and the white/red to the bottom terminal.

If continuity is not present as described, replace the switch.

Removal and Replacement:

1. Remove the blue wire and white/red from the start switch.
2. Compress the clips inside the hood and gently push the switch through the opening.
3. Push new switch into the opening and spread the clips to hold the start switch in the hood.
4. Refer to the following illustration when reconnecting the wires.

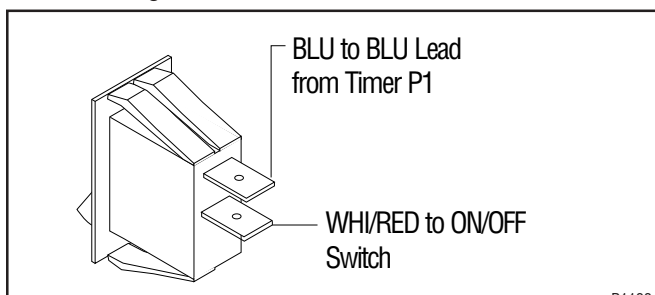

## SERVICE (cont.)

### TANK HEATER

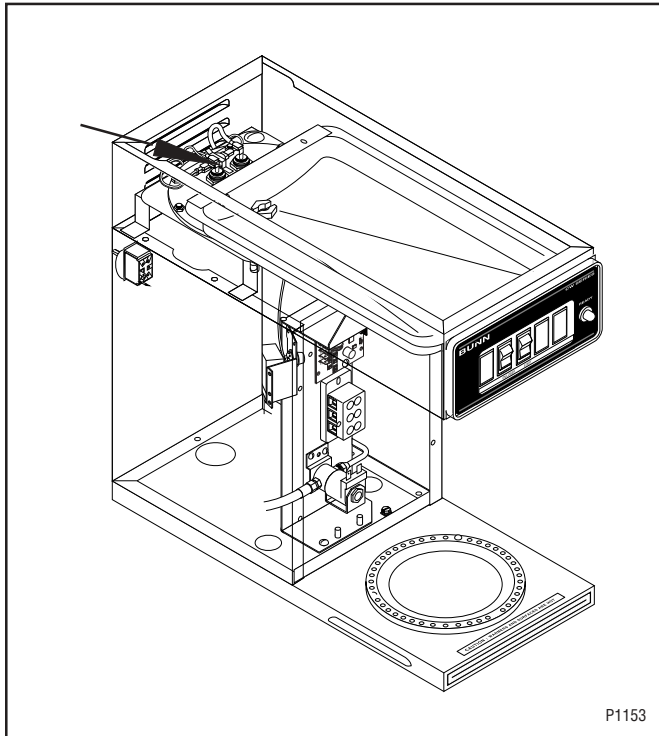

#### Location:

The tank heater is located inside the tank and secured to the tank lid.

#### Test Procedures:

1. Disconnect the brewer from the power supply.
2. Check the voltage across the black and white wires on 120 volt models or the black and red wires for 120/240 volt models, 200 volt models and 230 volt models with a voltmeter. Connect the brew to the power source. The indication must be:
  - a) 120 volts ac for two wire 120 volt 15 and 20 amp models.
  - b) 240 volts ac for three wire 120/240 volt models.
  - c) 200 to 230 volts ac for two wire 200 or 230 volt models.
3. Disconnect the brewer from the power source.

If voltage is present as described, proceed to #4  
If voltage is not present as described, refer to the *Wiring Diagrams* and check wiring harness.

4. Disconnect the black wire and the white or red wire from the tank heater terminals.

5. Check for continuity across the tank heater terminals.

If continuity is present as described, reconnect the wires, the tank heater is operating properly.

If continuity is not present as described, replace the tank heater.

**NOTE-** If the tank heater remains unable to heat, remove and inspect heater for cracks in the sheath.

#### Removal and Replacement:

1. Disconnect the water supply tube from the fill basin.
2. Remove the tank inlet fitting securing the fill basin to the tank lid, remove fill basin and tank inlet gasket. Set all three parts aside for reassembly.
3. On brewers with faucet shut-off water supply to the brewer and disconnect the inlet and outlet water lines to the faucet coil assembly.
4. Disconnect the black wire on the limit thermostat from the tank heater switch. On late model brewers also disconnect the blue wire from the limit thermostat to the control thermostat.
5. Disconnect the black wire and the white or red wire from the tank heater terminals.
6. Remove sprayhead and the hex nut securing the sprayhead tube to the hood. Set aside for reassembly.
7. Remove the eight #8-32 nuts securing the tank lid to the tank.
8. Remove the tank lid with limit thermostat, sprayhead tube, tank heater, coil assembly and control thermostat w/bracket (early models only).
9. Remove the two hex nuts securing the tank heater to the tank lid. Remove tank heater with gaskets and discard.
10. Install new tank heater with gaskets on the tank lid and secure with two hex nuts.
11. Install tank lid with limit thermostat, sprayhead tube, tank heater, coil assembly (brewers with faucet) and control thermostat with bracket (early brewers only) using eight #8-32 hex nut.
12. Reconnect the inlet and outlet water lines to the faucet coil assembly.
13. Secure sprayhead tube to hood using a hex nut.
14. Install sprayhead.

## SERVICE (cont.) TANK HEATER (Cont.)

15. Reconnect the wires to the limit thermostat, tank heater and control thermostat. See limit thermostat and control thermostat sections in this manual when reconnecting wires.
16. Install fill basin, secure with tank inlet fitting and gasket. Insert water supply line through grommet in fill basin.
17. Refer to the illustration below when reconnecting the tank heater wires.

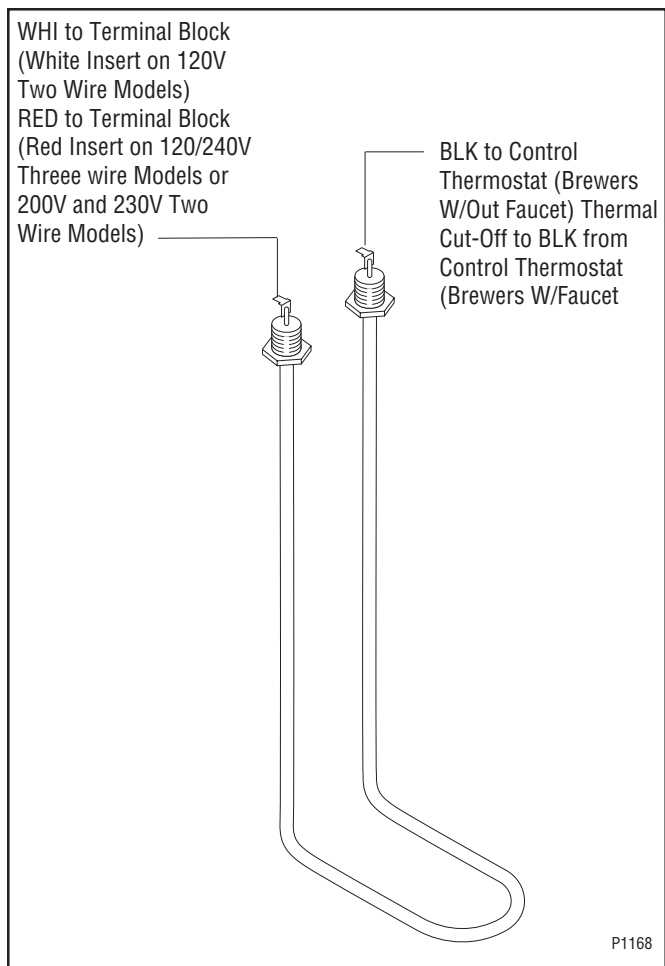

## TANK HEATER SWITCH

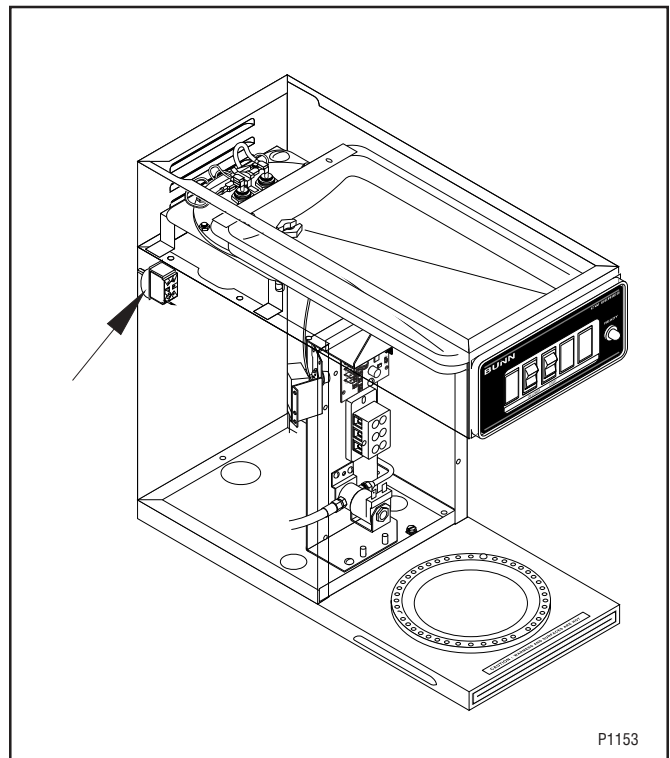

### Location:

The tank heater switch is located on the rear of the brewer on the upper left side of the trunk.

### Test Procedure:

1. Disconnect the brewer from the power source.
2. Disconnect the black wire from the limit thermostat.
3. With the tank heater switch in the "ON" position check the voltage between the black wire removed from the limit thermostat and the white wire or red wire on the tank heater with a voltmeter. Connect the brewer to the power source. The indication must be:
  - a) 120V volts ac on two wire 120 volt models.
  - b) 240 volts ac on three wire 120/240 volt models.
  - c) 200 to 230 volts ac on 200 volt or 230 volt models.
4. Disconnect the brewer from the power source.

If voltage is present as described, proceed to #5.  
If voltage is not present as described, refer to the *Wiring Diagrams* and check the brewer wiring harness.

## SERVICE (cont.)

### TANK HEATER SWITCH (cont.)

5. Check for continuity between the black wire removed from the limit thermostat and the black insert on the terminal block. with the tank heater switch in the "ON" upper position. Continuity should not be present in the "OFF" lower position.

If continuity is present as described, the tank heater switch is operating properly.

If continuity is not present as described, replace the tank heater switch.

#### Removal and Replacement:

1. Shut-off and disconnect the incoming water supply to the brewer.
2. On automatic brewers gently remove the fill tube from back of fill basin.
3. Remove the tank inlet fitting securing fill basin the tank lid. Remove fill basin and gasket. Set all three parts aside for reassembly.
4. On brewers with faucets, disconnect the water supply to coil assembly and remove the tube from the tank to the faucet.
5. Remove sprayhead and hex nut securing sprayhead tube to the hood. Set aside for reassembly.
6. Disconnect the wires on the limit thermostat and the tank heater and the control thermostat (early models).
7. Gently pull the thermostat sensor and grommet from the tank lid.
8. Insert a tube to the bottom of the tank and syphon ALL of the water out. (BUNN-O-MATIC has #12440 syphon assembly available for this purpose.
9. Gently reinstall the thermostat sensor and grommet in the tank lid.
10. Remove the two #8-32 screws securing the tank assembly to the hood.
11. Lift tank and components out as an assembly and set aside for reassembly.
12. Disconnect the two black wires from the tank heater switch.
13. Remove the plastic facenut, hex facenut and the switch indicator/guard bracket that secures tank heater switch to the rear of the brewer. Remove switch and discard.

14. Insert new tank heater switch through the hole in the upper left rear of the trunk and secure with switch indicator/guard bracket, hex facenut and plastic facenut.
15. Reconnect the two black wires to the tank heater switch terminals.
16. Set tank assembly inside the hood on mounting brackets and secure with two #8-32 screws.
17. Reconnect the wires to the limit thermostat, tank heater and the control thermostat. Refer to limit thermostat, tank heater and control thermostat sections in this manual when reconnecting wires.
18. Brewers with faucet reinstall the faucet tube and reconnect the water supply tube to the coil assembly.
19. Secure the sprayhead tube to the hood using hex nut.
20. Install sprayhead.
21. Install fill basin, inlet gasket and secure to tank lid with tank inlet fitting.
22. Carefully install water fill tube into the back of the fill basin.
23. Reconnect and turn on the incoming water supply.
24. Refer to the illustration below when reconnecting the wires.

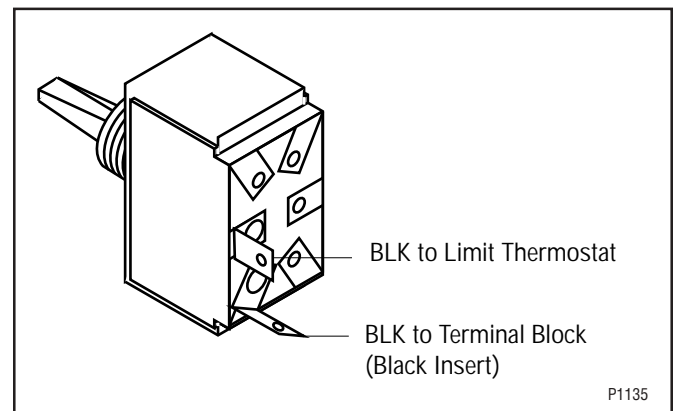

## SERVICE (cont.)

### DIAL TIMER (Early Models) - CT & CWT

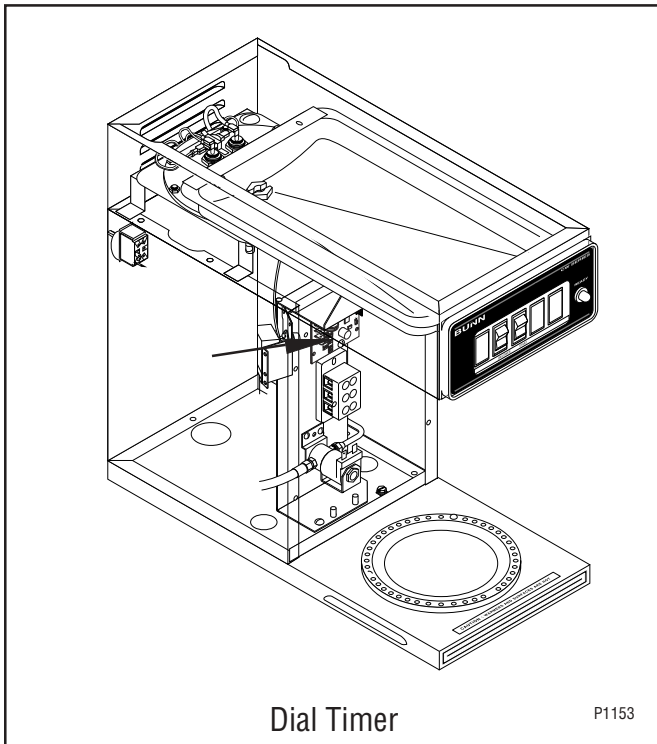

#### Location:

The timer is located inside the front of the trunk on the upper right side of component bracket.

#### Test Procedure (Dial Timer).

1. Disconnect the brewer from the power source.
2. Disconnect the polarized, three pin connector from the brewer wiring harness and rotate the brew timer dial fully counterclockwise.
3. Check the voltage across sockets P2 & P3 (white and black wires) of the female connector with a voltmeter when the "ON/OFF" is in the "ON" position (upper). Connect the brewer to the power source. The indication must be:
  - a) 120 volts ac for two wire 120 volt models and three wire 120/240 volt models.
  - b) 200 to 230 volts ac on two wire 200 volt or 230 volt models.
4. Disconnect the brewer from the power source.

If voltage is present as described, proceed to #5.  
If voltage is not present as described, refer to the Wiring Diagrams and check the brewer wiring harness.

5. Check the voltage across the sockets P1 & P2 (blue and white wires) of the female connector

with a voltmeter when the "ON/OFF" switch is in the "ON" position (upper) and start switch pressed. Connect the brewer to the power source. The indication must be:

- a) 120 volts ac for two wire 120 volt models and three wire 120/240 volt models.
  - b) 200 to 230 volts ac for two wire 200 volt or 230 volt models.
6. Disconnect the brewer from the power source.
  7. Reconnect the three pin connector from main wiring harness to the timer.

If voltage is present as described, proceed to #7  
If voltage is not present as described, refer to Wiring Diagrams and check the brewer wiring harness.

7. Disconnect the black and white wires from the solenoid.
8. Check the voltage across the black and white wires with a voltmeter when the "ON/OFF" switch is in the "ON" position (upper) and the "START" switch is pressed to the "START" position (lower) and released. Connect the brewer to the power source. The indication must be:
  - a) 120 volts ac for approximately 20 seconds for two wire 120 volt models and three wire 120/240 volt models.
  - b) 200 to 230 volts ac for approximately 20 seconds for two wire 200 volt or 230 volt models.

If voltage is present as described, the brew timer is operating properly. Reset the timer dial as required, to obtain the desired brew volume.

If voltage is not present as described, replace the timer.

#### Removal and Replacement (Dial Timer):

1. Disconnect the timer socket from the brewer wiring harness and the timer leads from the solenoid valve.
2. Remove the one #8-32 screw securing timer to component bracket.
3. Install new timer on component bracket securing with one #8-32 screw.
4. Refer to the following illustration when reconnecting the wires.
5. Readjust the timer dial as required.



**SERVICE (cont.)**  
**DIAL TIMER (Early Models) (cont.)**

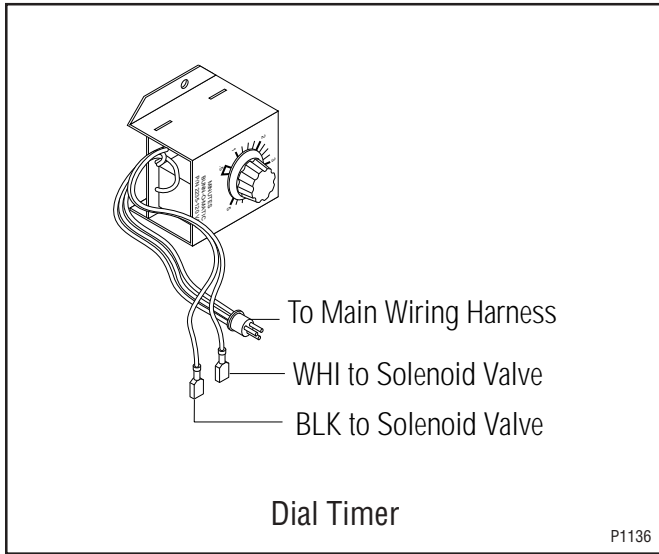

2. Remove the #8-32 screw securing circuit board to the mounting bracket.
3. Remove circuit board and spacers (as required).
4. With a voltmeter, check the voltage across terminals TL1 and TL2 when the "ON/OFF" switch is in the "ON" position. Connect the brewer to the power source. The indication must be:
  - a) 120 volts ac for two wire 120 volt models and three wire 120/240 volt models.
  - b) 200 to 230 volts ac on two wire 200 volt or 230 volt models.
5. Disconnect the brewer from the power source.

If voltage is present as described, proceed to #6. If voltage is not present as described, refer to the *Wiring Diagrams* and check the brewer wiring harness.

**DIGITAL BREW TIMER (Late Models)**

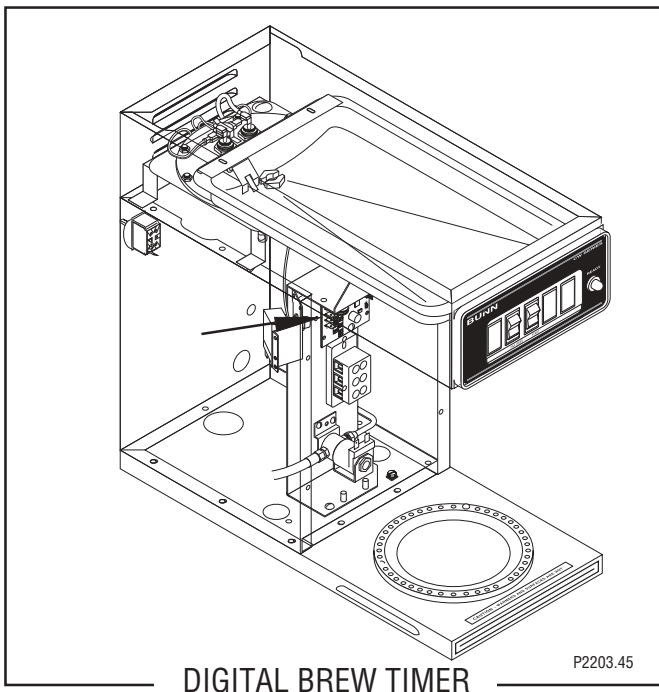

Location:

The timer is located inside the front of the trunk on the upper right side of component bracket.

Test Procedure (Digital Timer):

**NOTE:** Do not remove or install wires while timer board is installed. Pressure applied to one side may cause damage to the board.

1. Disconnect the brewer from the power source and remove the front access panel.

6. With a voltmeter, check the voltage across terminals TL1 and TL4 when the "ON/OFF" switch is in the "ON" position. Connect the brewer to the power source. The indication must be 0 volts.

If voltage is as described, proceed to #7.

If voltage is not as described, disconnect the brewer from the power source and replace the timer.

7. With a voltmeter, check the voltage across terminals TL1 and TL4 when the "ON/OFF" switch is in the "ON" position. Connect the brewer to the power source and press the "START" switch. The indication must be as follows:
  - a) 120 volts ac for two wire 120 volt models and three wire 120/240 volt models.
  - b) 200 to 230 volts ac on two wire 200 volt or 230 volt models.

If voltage is present as described, the brew timer is operating properly. Reset the timer as required, to obtain the desired brew volume.

If voltage is not present as described, disconnect the brewer from the power source and replace the timer.

Removal and Replacement (Digital Timer):

1. Remove the #8-32 screw securing circuit board to the mounting bracket.
2. Remove circuit board and spacers (as required).
3. Remove all wires from the timer.

## SERVICE (cont.)

### DIGITAL BREW TIMER (Late Models)(cont.)

4. Attach all wires to the replacement timer board prior to installation to the component mounting bracket. Refer to FIG. 21 when reconnecting the wires.
5. Install new circuit board with spacers (as required) to the component mounting bracket.
6. Adjust the timer as described below.

#### Timer Setting (Digital):

**NOTE:** Prior to setting or modifying volumes, check that the brewer is connected to water supply, the tank is properly filled, and a funnel and server are in place.

**NOTE:** All volume settings must be done with the sprayhead installed.

1. **Modifying brew volumes.** To modify a brew volume, first check that the SET/LOCK switch is in the "SET" position on the circuit board.

**To increase a brew volume,** place the ON/OFF switch in the "ON" position, press and hold the START switch until three clicks are heard. Release the switch and press it again one or more times. (Failure to release the switch within two seconds after the third click causes the volume setting to be aborted and previous volume setting will remain in memory) Each time the switch is pressed, two seconds are added to the brew time period. Allow the brew cycle to finish in order to verify that the desired volume has been achieved.

**To decrease a brew volume,** place the ON/OFF switch in the "ON" position, press and release the START switch once for every two-second interval to be removed from the total brew time period; then immediately press and hold down the START switch until three clicks are heard. Release the switch. (Failure to release the switch within two seconds after the third click causes the volume setting to be aborted and previous volume setting will remain in memory). Allow the brew cycle to finish in order to verify that the desired volume has been achieved.

2. **Setting brew volumes.** To set a brew volume, first check that the SET/LOCK switch is in the "SET" position on the circuit board. Place the ON/OFF switch in the "ON" position. Models Single CW only, place

the selector switch in the half position. Press and hold the START switch until three distinct clicks are heard and then release the switch. (Failure to release the switch within two seconds after the third click causes the volume setting to be aborted and previous volume setting will remain in memory.)

View the level of the liquid being dispensed. When approximately 50 ounces is reached, turn the ON/OFF switch to "OFF".

**NOTE:** Several ounces of water will continue to syphon from the tank after turning the switch "OFF". The brewer remembers this volume and will continue to brew batches of this size until the volume setting procedure is repeated.

**NOTE:** When brewing coffee, volume will decrease due to absorption by the coffee grounds.

3. **Setting programming disable feature.** If it becomes necessary to prevent anyone from changing brew time once programmed, you can set the SET/LOCK switch to the "LOCK" position. This will prevent any further programming until switch is once again put into the "SET" position.

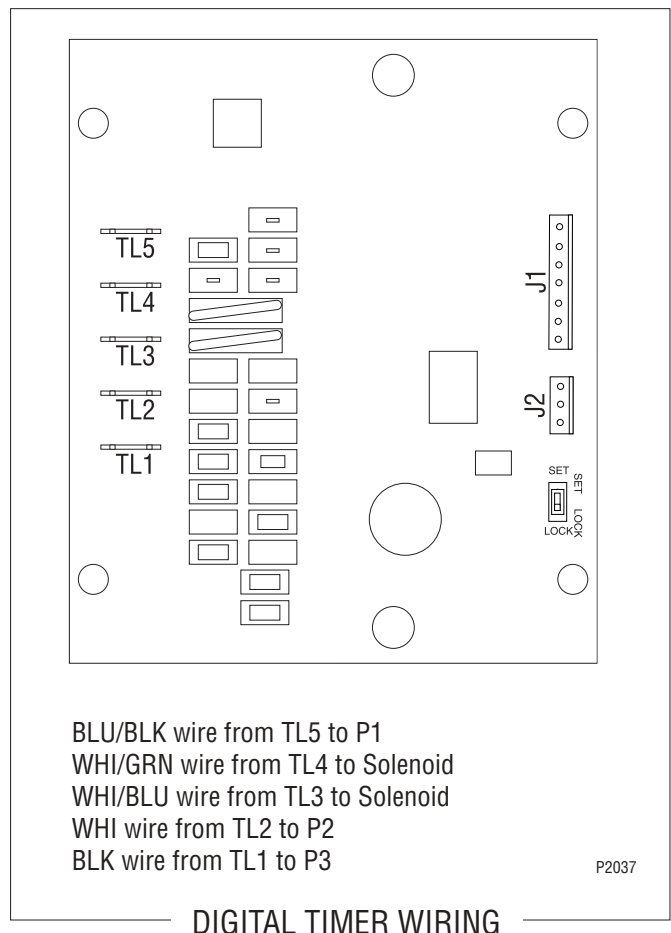

**SERVICE (cont.)**  
**WARMER ELEMENT(S)**

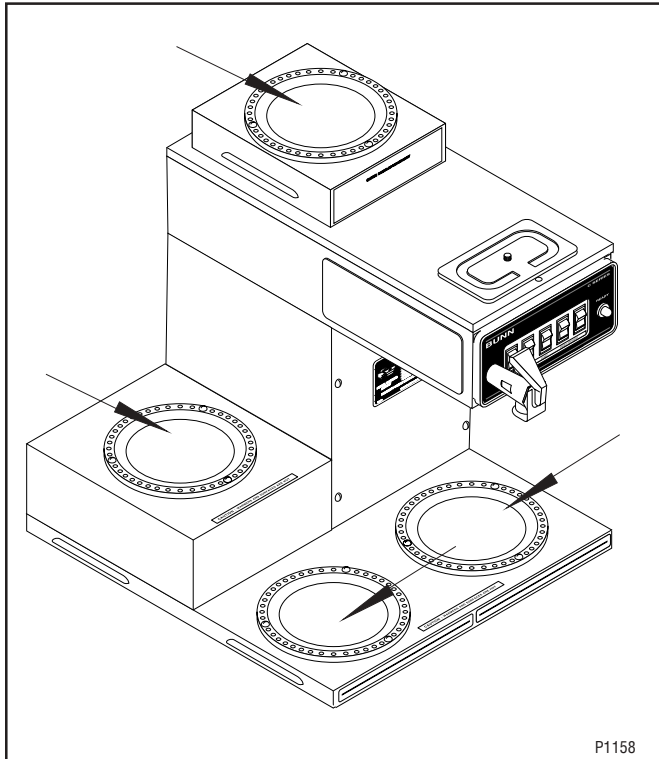

Location:

The warmer element(s) is located under the warmer plate.

Test Procedures:

1. Disconnect the brewer from the power source.
2. Use the white or red wire to the terminal block and the white/red, brown/black or violet wire to the "ON/OFF" switch.
3. Check voltage across the white or red and white/red, brown/black or violet with a voltmeter with the "ON/OFF" switch in the "ON" position. The indication must be:
  - a) 120 volts ac for two wire 120 volt models and three wire 120/240 volt models.
  - b) 200 to 230 volts ac for two wire 200 or 230 volt models.
4. Disconnect the brewer from the power source.

If voltage is present as described, proceed to #5.  
 If voltage is not present as described, refer to wiring diagrams and check brewer wiring harness.

5. Check the continuity across the two terminals on the warmer element.

If continuity is present as described, reconnect the white or red and white/red, and brown/black or violet wires on the warmer element.

If continuity is not present as described, replace the warmer element.

Removal and Replacement:

1. Remove the three #4-40 screws securing the warmer assembly to the brewer.
2. Lift the warmer assembly from the brewer.
3. Disconnect the two wires from the warmer element terminals.
4. Remove the two #8-32 nuts securing the warmer element to the warmer plate.
5. Securely install new warmer element.
6. Reconnect the two wires to warmer element terminals.
7. Securely install warmer assembly on the brewer.
8. Refer to the illustration below when reconnecting the wires.

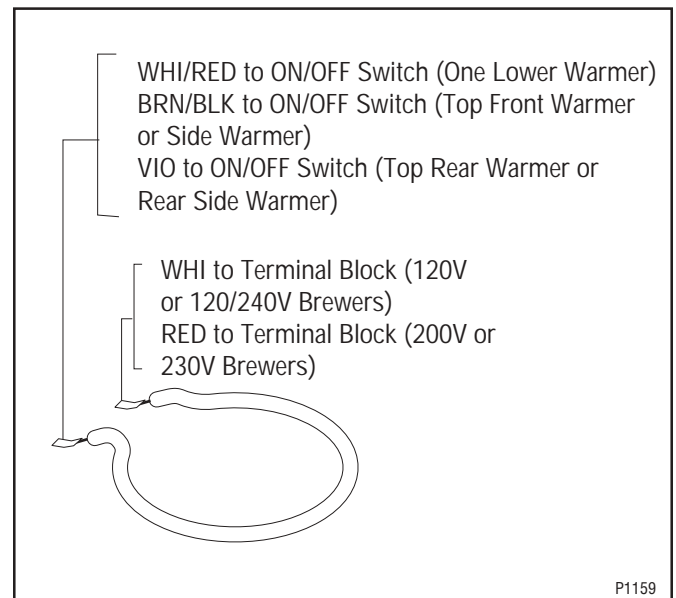

# SCHEMATIC WIRING DIAGRAM C, CT & CWT

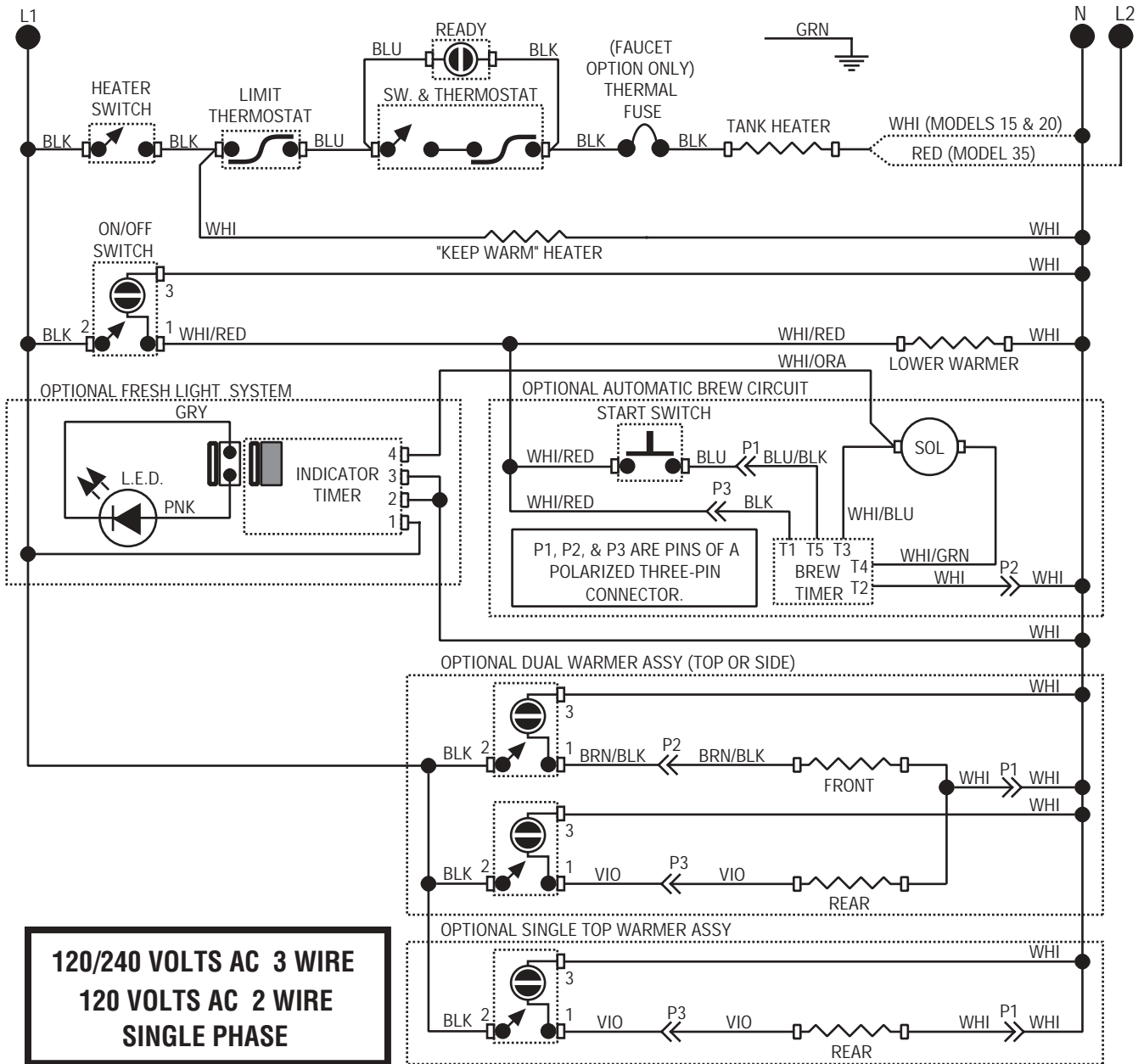

# SCHEMATIC WIRING DIAGRAM CWTB

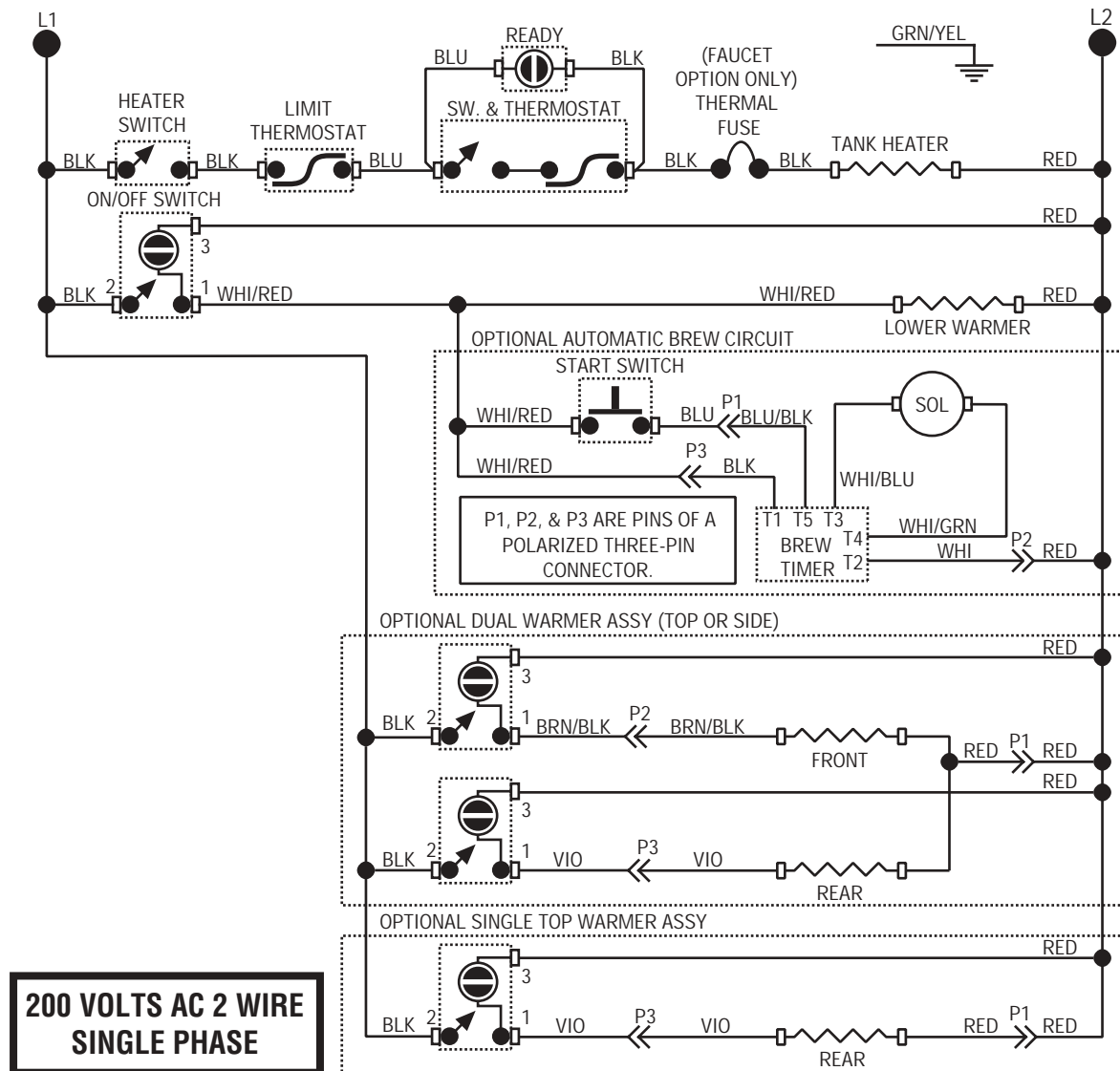

# SCHEMATIC WIRING DIAGRAM CWTA

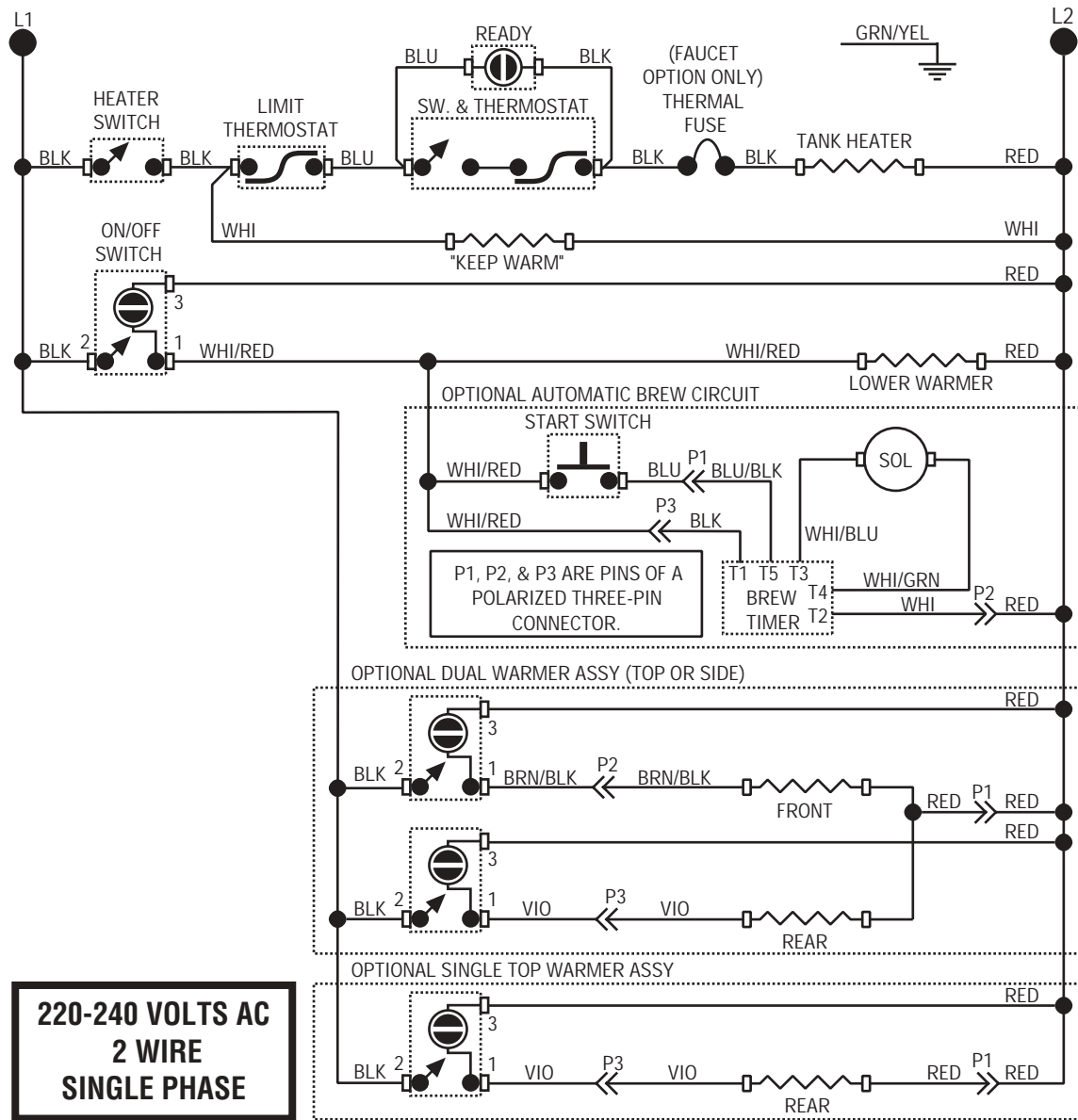

**220-240 VOLTS AC  
2 WIRE  
SINGLE PHASE**

# SCHEMATIC WIRING DIAGRAM CWTF, CWTFB NO WARMER

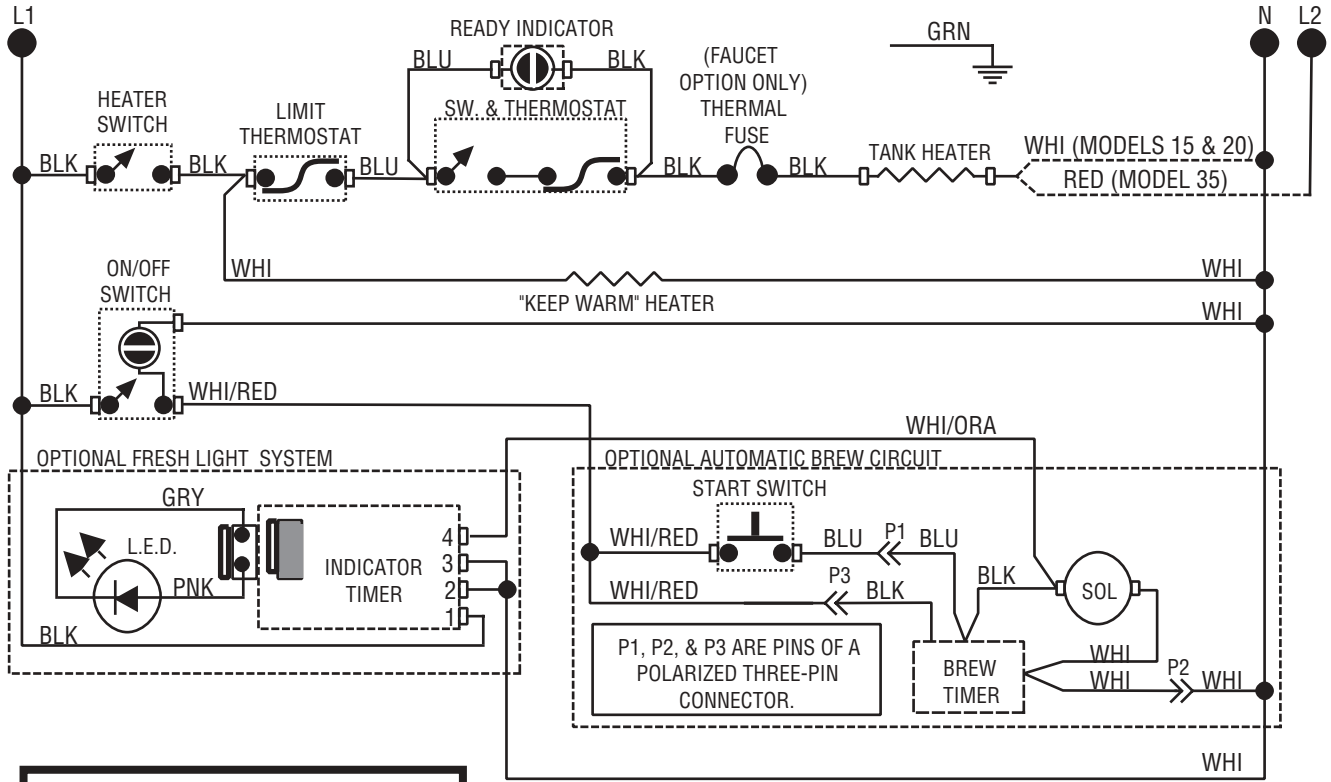

**120/240 VOLTS AC 3 WIRE  
100-120 VOLTS AC 2 WIRE  
SINGLE PHASE**

## SCHEMATIC WIRING DIAGRAM CWTF A NO WARMER

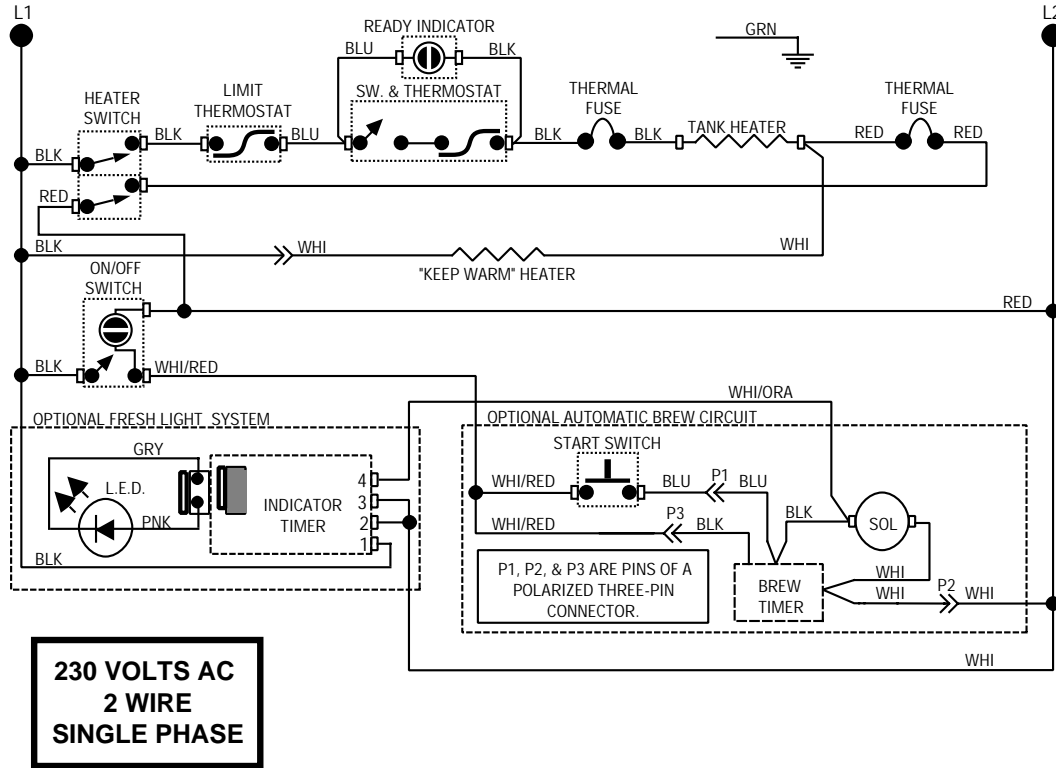

## SCHEMATIC WIRING DIAGRAM SINGLE CW

