

BUNN[®]

FMD-2

FMD-3

(prior to S/N FMD0013000)

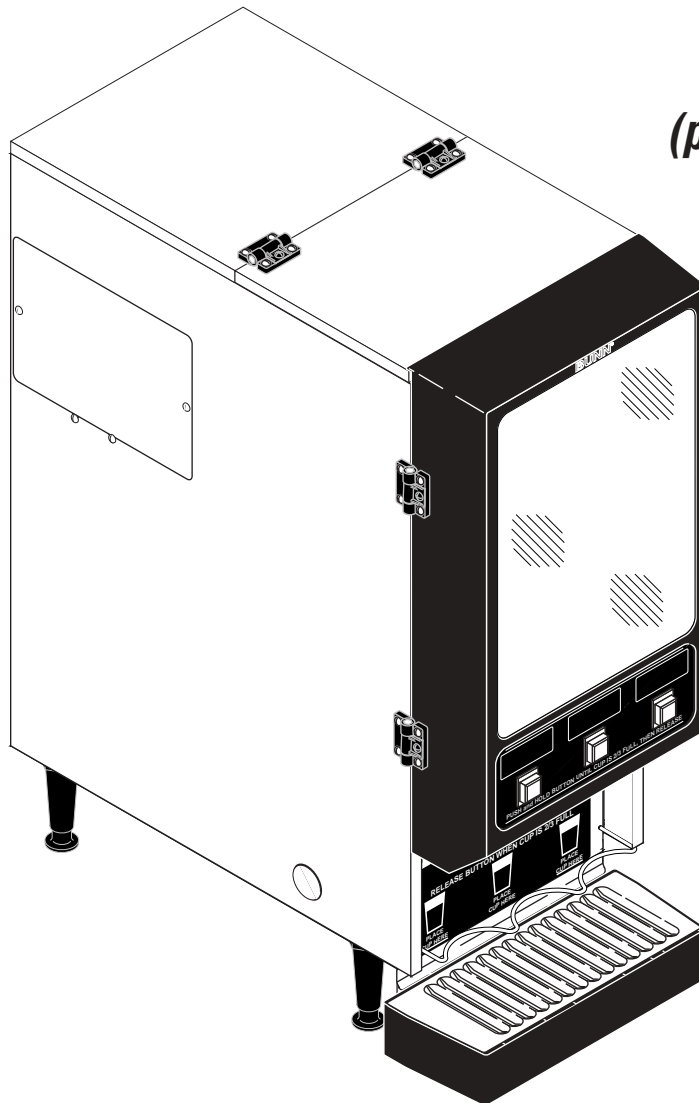

OPERATING & SERVICE MANUAL

BUNN-O-MATIC CORPORATION

POST OFFICE BOX 3227

SPRINGFIELD, ILLINOIS 62708-3227

PHONE: (217) 529-6601 FAX: (217) 529-6644

INTRODUCTION

This equipment dispenses hot beverages on demand from powdered product. It has two or three hoppers. The two and three hopper models may also dispense cold beverages from powdered product from their left dispense station. It is for indoor use only on a sturdy counter or shelf.

BUNN-O-MATIC COMMERCIAL PRODUCT WARRANTY

Bunn-O-Matic Corp. ("BUNN") warrants equipment manufactured by it as follows:

- 1) All equipment other than as specified below: 2 years parts and 1 year labor.
- 2) Electronic circuit and/or control boards: parts and labor for 3 years.
- 3) Compressors on refrigeration equipment: 5 years parts and 1 year labor.
- 4) Grinding burrs on coffee grinding equipment to grind coffee to meet original factory screen sieve analysis: parts and labor for 3 years or 30,000 pounds of coffee, whichever comes first.

These warranty periods run from the date of installation BUNN warrants that the equipment manufactured by it will be commercially free of defects in material and workmanship existing at the time of manufacture and appearing within the applicable warranty period. This warranty does not apply to any equipment, component or part that was not manufactured by BUNN or that, in BUNN's judgment, has been affected by misuse, neglect, alteration, improper installation or operation, improper maintenance or repair, damage or casualty. This warranty is conditioned on the Buyer 1) giving BUNN prompt notice of any claim to be made under this warranty by telephone at (217) 529-6601 or by writing to Post Office Box 3227, Springfield, Illinois 62708-3227; 2) if requested by BUNN, shipping the defective equipment prepaid to an authorized BUNN service location; and 3) receiving prior authorization from BUNN that the defective equipment is under warranty.

THE FOREGOING WARRANTY IS EXCLUSIVE AND IS IN LIEU OF ANY OTHER WARRANTY, WRITTEN OR ORAL, EXPRESS OR IMPLIED, INCLUDING, BUT NOT LIMITED TO, ANY IMPLIED WARRANTY OF EITHER MERCHANTABILITY OR FITNESS FOR A PARTICULAR PURPOSE. The agents, dealers or employees of BUNN are not authorized to make modifications to this warranty or to make additional warranties that are binding on BUNN. Accordingly, statements by such individuals, whether oral or written, do not constitute warranties and should not be relied upon.

If BUNN determines in its sole discretion that the equipment does not conform to the warranty, BUNN, at its exclusive option while the equipment is under warranty, shall either 1) provide at no charge replacement parts and/or labor (during the applicable parts and labor warranty periods specified above) to repair the defective components, provided that this repair is done by a BUNN Authorized Service Representative; or 2) shall replace the equipment or refund the purchase price for the equipment.

THE BUYER'S REMEDY AGAINST BUNN FOR THE BREACH OF ANY OBLIGATION ARISING OUT OF THE SALE OF THIS EQUIPMENT, WHETHER DERIVED FROM WARRANTY OR OTHERWISE, SHALL BE LIMITED, AT BUNN'S SOLE OPTION AS SPECIFIED HEREIN, TO REPAIR, REPLACEMENT OR REFUND.

In no event shall BUNN be liable for any other damage or loss, including, but not limited to, lost profits, lost sales, loss of use of equipment, claims of Buyer's customers, cost of capital, cost of down time, cost of substitute equipment, facilities or services, or any other special, incidental or consequential damages.

USER NOTICES

Carefully read and follow all notices on the equipment and in this manual. They were written for your protection. All notices are to be kept in good condition. Replace any unreadable or damaged labels.

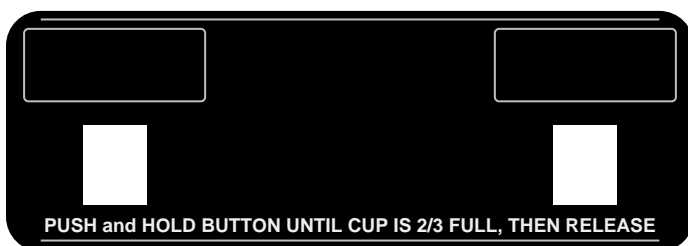

FMD-2 28301.0002



FMD-3 28301.0000

USER NOTICES (cont.)

⚠ WARNING

- ◆ Fill water tank before turning -on thermostat or connecting appliance to power source.
- ◆ Use only on a properly protected circuit capable of the rated load.
- ◆ Electrically ground the chassis.
- ◆ Follow national/local electrical codes.
- ◆ Do not use near combustibles.

FAILURE TO COMPLY RISKS EQUIPMENT DAMAGE, FIRE, OR SHOCK HAZARD

READ THE ENTIRE OPERATING MANUAL BEFORE BUYING OR USING THIS PRODUCT

THIS APPLIANCE IS HEATED WHENEVER CONNECTED TO A POWER SOURCE

00831.0000F 3/98 © 1988 BUNN-O-MATIC CORPORATION

00831.0000

This equipment is to be installed to comply with the Basic Plumbing Code of the Building Officials and Code Administrators International, Inc. (BOCA) and the Food Service Sanitation Manual of the Food and Drug Administration (FDA).

00656.0000

CONTROL THERMOSTAT ADJUSTMENT

200° F 190° F 180° F

APPROXIMATE THERMOSTAT TEMPERATURE SETTINGS

28368.0000A 10/97 © 1997 BUNN-O-MATIC CORPORATION

MECHANICAL THERMOSTAT
28368.0000

TEMPERATURE ADJUSTMENT HEATER

26527.0002
THERMOSTAT ASSEMBLY
BUNN-O-MATIC CORP

120VAC

ELECTRONIC THERMOSTAT
26536.0002

⚠ WARNING
HOT LIQUID

RELEASE BUTTON WHEN CUP IS 2/3 FULL

PLACE CUP HERE PLACE CUP HERE

FMD-2
28328.00003

⚠ WARNING
HOT LIQUID

RELEASE BUTTON WHEN CUP IS 2/3 FULL

PLACE CUP HERE PLACE CUP HERE PLACE CUP HERE

FMD-3
28328.0000

INITIAL SET-UP

1. Locate the drip tray assembly beneath the dispenser nested in the packing material.
2. Remove the drip tray and the drip tray cover and set them aside.
3. Remove the water strainer assembly from the drip tray and set it aside.
4. Remove the four legs from the drip tray, apply non-skid pads to the bottom of the legs and securely install the legs in the dispenser base.

ELECTRICAL REQUIREMENTS

CAUTION - The dispenser must be disconnected from the power source until specified in *Initial Set-Up*.

The 120 volt version of this dispenser has an attached cordset. The mating connector must be a NEMA 5-15R. The 120/208 volt and the 120/240 version of this dispenser has an attached cordset. The mating connector must be a NEMA 14-20R.

The 240 volt version of this dispenser has an attached cordset without plug.

ELECTRICAL HOOK-UP

CAUTION - Improper electrical installation will damage electronic components.

1. An electrician must provide electrical service as specified.
2. Using a voltmeter, check the voltage and color coding of each conductor at the electrical source.
3. Open the front door of the dispenser and place the heater switch in the "OFF" (upper position).
4. Connect the dispenser to the power source.
5. If plumbing is to be hooked-up later be sure the dispenser is disconnected from the power source. If plumbing has been hooked-up, the dispenser is ready for *Initial Fill & Heat*.

PLUMBING REQUIREMENTS

This dispenser must be connected to a **COLD WATER** system with operating pressure between 20 and 90 psi (138 and 620 kPa) from a $\frac{1}{2}$ " or larger supply line. A shut-off valve should be installed in the line before the dispenser. Install a regulator in the line when pressure is greater than 90 psi (620 kPa) to reduce it to 50 psi (345 kPa). The water inlet fitting is $\frac{1}{4}$ " flare.

NOTE - Bunn-O-Matic recommends $\frac{1}{4}$ " copper tubing for installations of less than 25 feet and $\frac{3}{8}$ " for more than 25 feet from the $\frac{1}{2}$ " water supply line. At least 18 inches of an FDA approved flexible beverage tubing, such as reinforced braided polyethylene or silicone, before the dispenser will facilitate movement to clean the countertop. It can be purchased direct from Bunn-O-Matic (part number 00326-0000). Bunn-O-Matic does not recommend the use of a saddle valve to install the dispenser. The size and shape of the hole made in the supply line by this type of device may restrict water flow.

This equipment must be installed to comply with the Basic Plumbing Code of the Building Officials and Code Administrators International, Inc. (BOCA) and the Food Service Sanitation Manual of the Food and Drug Administration (FDA).

PLUMBING HOOK-UP

1. Securely attach the short piece of tubing on the water strainer assembly to the inlet fitting on the bottom of the dispenser.
2. Flush the water line and securely attach it to the flare fitting on the water strainer assembly.
3. Turn-on the water supply.

INITIAL FILL & HEAT

CAUTION - The dispenser must be disconnected from the power source throughout the initial fill & heat, except when specified in the instructions.

1. Turn-on the water supply and connect the dispenser to the power source.
2. Water will automatically flow into the tank to the proper level and then shut-off. This will take less than five minutes.
3. When the tank is full of water, open the front door and place the heater switch in the “ON” (lower) position. A tank full of cold water will take approximately forty minutes for the water to heat on 120 volt versions, and twenty minutes on 120/240 and 240 volt versions.

During this waiting period, complete these dispenser set-up steps:

- a. Place a set of keyholes in the splash panel over the screws beneath the hopper access door and push down gently.
- b. Place the drip tray onto the supports on the splash panel. Hook the tabs on the rear of the drip tray through the holes in the splash panel. Set the drip tray cover in place.
- c. Fill the hopper(s) with the dry product to be dispensed.

DISPENSER USE

1. Simply place a cup on the drip tray beneath the desired dispensing tip.
2. Press the button to froth and dispense the beverage.
3. Release the button when the cup is approximately $\frac{2}{3}$ full and allow the mixing chamber to drain.

NOTE - The mixing chamber must drain at the end of each dispense.

COLD BEVERAGE SET-UP (OPTIONAL)

Cold beverages may be dispensed from the left dispense position on the FMD-2 & FMD-3 models. Simply place the HOT/COLD switch near the left whipper chamber in the “COLD” (upper) position.

CLEANING

Refer to the decal inside the hopper access door for cleaning recommendations and procedures.

The use of a damp cloth rinsed in any mild, non-abrasive, liquid detergent is recommended for cleaning all surfaces on Bunn-O-Matic equipment.

ADJUSTMENTS

The hot or cold beverage solenoid(s) is (are) preset to dispense approximately one ounce per second. This amount can be adjusted:

1. Disconnect the dispenser from the power source.
2. Remove the small left side access panel.
3. Rotate the control at the base of the desired solenoid(s) clockwise to decrease or counterclockwise to increase the amount of water.
4. For cold beverage adjustment remove the 1-1/2” plug on the lower left side of the dispenser and rotate the needle valve clockwise to decrease or counterclockwise to increase the amount of cold water.

DRAINING THE HOT WATER TANK

CAUTION - The dispenser must be disconnected from the power source throughout these steps.

1. Disconnect the dispenser from the power source.
2. Open front door and place tank heater switch in the "OFF" (upper) position.
3. Shut-off and disconnect the incoming water supply.
4. Remove the top panel.
5. Gently remove one of the grommets from the tank lid.
6. Insert a tube to the bottom of the tank and syphon ALL of the water out.
(Bunn-O-Matic has a syphon assembly #12440.0000 available for this purpose.)

NOTE - The dispenser must be refilled using the INITIAL FILL & HEAT steps before reconnecting to the power source.

HOPPER DISPENSE RATE OF PRODUCT

1. Hopper dispense rate with 22 tooth gear and auger wire is approximately 4 to 6 grams per second.
2. Hopper dispense rate with 22 tooth gear and auger wire with optional restrictor is approximately 3 to 5 grams per second.
3. Hopper dispense rate with optional 32 tooth gear and auger wire is 6 to 9 grams per second.

TROUBLESHOOTING

A troubleshooting guide is provided to suggest probable causes and remedies for the most likely problems encountered. If the problem remains after exhausting the troubleshooting steps, contact the Bunn-O-Matic Technical Service Department.

- Inspection, testing, and repair of electrical equipment should be performed only by qualified service personnel.
- All electronic components have 120 volt ac or 240 volt ac and low voltage dc potential on their terminals. Shorting of terminals or the application of external voltages may result in board failure.
- Intermittent operation of electronic circuit boards is unlikely. Board failure will normally be permanent. If an intermittent condition is encountered, the cause will likely be a switch contact or a loose connection at a terminal or crimp.
- Solenoid removal requires interrupting the water supply to the valve. Damage may result if solenoids are energized for more than ten minutes without a supply of water.
- The use of two wrenches is recommended whenever plumbing fittings are tightened or loosened. This will help to avoid twists and kinks in the tubing.
- Make certain that all plumbing connections are sealed and electrical connections tight and isolated.
- This unit is heated at all times. Keep away from combustibles.

- WARNING** –
- Exercise extreme caution when servicing electrical equipment.
 - Unplug the dispenser when servicing, except when electrical tests are specified.
 - Follow recommended service procedures
 - Replace all protective shields or safety notices

TROUBLESHOOTING (cont.)

PROBLEM	PROBABLE CAUSE	REMEDY
Product will not dispense	1. No water	Water lines and valves to the dispenser must be open.
	2. No power or incorrect voltage to the dispenser	(A1) Check for 120 volts across the black and white wires on two wire 120 volt dispenser. (A2) Check for 120 volts across the red and white wires and the black and white wires on three wire 120/240 volt dispenser. (A3) Check for 240 volts across the white and black wires on two wire 240 volt dispenser. (B) Check circuit breakers or fuses.
	3. Dispense switch	Refer to <i>Service</i> - Dispense Switch for testing procedure. See page 17
	4. Dispense solenoid valve (Hot or Cold)	Refer to <i>Service</i> - Dispense solenoid valve for testing procedures. See page 29 or 30
	5. Solenoid valve (Inlet)	Refer to <i>Service</i> - Solenoid Valve (Inlet) for testing procedures. See page 31
	6. Level control board and probe	Refer to <i>Service</i> - Level Control Board and Probe for testing procedures. See page 24
	7. Overflow protection switch	Refer to <i>Service</i> - Overflow protection switch for testing procedures. See page 27
	8. Auger drive	Refer to <i>Service</i> - Auger Drive. See page 12

TROUBLESHOOTING (cont.)

PROBLEM

PROBABLE CAUSE

REMEDY

Product will not dispense (cont.)

9. Water strainer

(A) Direction of flow arrow must be pointing towards dispenser.

(B) Remove the strainer and check for obstructions. Clear or replace.

10. Lime build-up

CAUTION - Tank and tank components should be delimed regularly depending on local water conditions. Excessive mineral build-up on stainless steel surfaces can initiate corrosive reactions resulting in serious leaks.

Inspect the tank assembly for excessive lime deposits. Delime as required.

Water is not hot

1. Limit thermostat

CAUTION - Do not eliminate or bypass limit thermostat. Use only BOM replacement part #29329.1000

Refer to *Service* - Limit Thermostat for testing procedures. See page 26

2. Control thermostat

Refer to *Service* - Control Thermostat for testing procedures. See page 16

3. Tank Heater

Refer to *Service* - Tank Heater for testing procedures. See page 32

4. Tank heater switch

Refer to *Service* - Tank Heater Switch for testing procedures. See page 33

Spitting or excessive steaming

1. Lime build-up

CAUTION - Tank and tank components should be delimed regularly depending on local water conditions. Excessive mineral build-up on stainless steel surfaces can initiate corrosive reactions resulting in serious leaks.

Inspect tank assembly for excessive lime deposits. Delime as required.

2. Control thermostat

Refer to *Service* - Control Thermostat for testing procedures. See page 16

TROUBLESHOOTING (cont.)
PROBLEM

PROBABLE CAUSE

REMEDY

Dripping from dispense tip

1. Lime build-up
CAUTION - Tank and tank components should be delimed regularly depending on local water conditions. Excessive mineral build-up on stainless steel surfaces can initiate corrosive reactions resulting in serious leaks.

Inspect the tank assembly for excessive lime deposits. Delime as required.

2. Dispense solenoid valve (Hot or Cold)

Remove the dispense solenoid valve and clear any obstructions. Rebuild or replace the valve if necessary. See page 29 or 30

Water flows into tank continuously

1. Level control board and probe

Refer to *Service* - Level Control Board and Probe for testing procedures. See page 24

2. Solenoid valve (Inlet)

Refer to *Service* - Solenoid Valve (Inlet) for testing procedures. See page 31

3. Overflow Protection Switch

Refer to *Service* - Overflow Protection Switch for testing procedures. See page 27

Product overflows container

1. Dispense switch

Refer to *Service* - Dispense Switch for testing procedures. See page 17

2. Dispense solenoid valve (Hot or Cold)

Remove the solenoid valve and clear any obstructions. Rebuild or replace the valve if necessary. See page 29 or 30

TROUBLESHOOTING (cont.)

PROBLEM

Weak product

PROBABLE CAUSE

1. Water temperature

REMEDY

Place an empty container beneath the dispense tip. Initiate a dispense cycle and check the water temperature immediately below the dispense tip with a thermometer.

(A) Reading for mechanical thermostat models should be 180°F to 200°F (see thermostat temperature settings decal in *USER NOTICES* on page 3.

(B) Reading for electronic thermostat should be 185°F to 190°F.

Adjust the control thermostat to increase or decrease the water temperature. Replace if necessary.

2. Whipper motor

Refer to *Service* - Whipper Motor for testing procedure. See page 19

3. Frother

Refer to *Service* - Frother Components. See page 19

4. Dispense solenoid valve (Hot or Cold)

Refer to *Service* - Dispense Solenoid Valve for test procedures. See page 29 or 30

5. Auger drive

Refer to *Service* - Auger Drive Components. See page 12

6. Auger spring

Refer to *Service* - Auger Drive Components. See page 12

7. Auger motor

Refer to *Service* - Auger Drive Components. See page 14

8. Rinse/Run switch

Refer to *Service* - Rinse/Run Switch for test procedures. See page 28

TROUBLESHOOTING (CONT.)

PROBLEM	PROBABLE CAUSE	REMEDY
Dispenser is making unusual noises	1. Plumbing Lines	Plumbing lines should not be resting on the counter top.
	2. Water Supply	(A) The dispenser must be connected to a cold water line (B) Water pressure to the dispenser must not exceed 90 psi (620 kPa). Install a regulator if necessary to lower the working pressure to approximately 50 psi (345 kPa).
	3. Tank Heater	Remove and clean lime off the tank heater. See page 32
Excess dust	1. Fan	Refer to <i>Service</i> - Fan for testing procedures. See page 18
	2. Hopper Delay Board	Refer to <i>Service</i> -Hopper Delay Board for testing procedures. See page 21
Display not lit	1. Lamp	Refer to <i>Service</i> - Lamp, see page 23 for lamp replacement.
	2. Lamp Holder	Refer to <i>Service</i> - Lamp Holder for testing procedures. See page 23
	3. Starter - Lamp	Refer to <i>Service</i> - Starter for testing procedures. See page 24
	4. Ballast	Refer to <i>Service</i> - Ballast for testing procedures. See page 15

SERVICE

This section provides procedures for testing and replacing various major components used in this dispenser should service become necessary. Refer to *Troubleshooting* for assistance in determining the cause of any problem.

WARNING - Inspection, testing, and repair of electrical equipment should be performed only by qualified service personnel. The dispenser should be unplugged when servicing, except when electrical tests are required and the test procedure specifically states to plug-in the dispenser.

COMPONENT ACCESS

WARNING - Disconnect the dispenser from the power source before the removal of any panel or the replacement of any component.

All components are accessible by opening the door, removal of the door panels, dispenser top covers, hoppers, hopper support plate, splash guard, splash panel w/drip tray, lower front access panel, side and rear access covers.

Contents

Auger Drive Components	12
Auger Motor	14
Ballast	15
Control Thermostat	16
Dispense Switch	17
Fan	18
Frother	19
Hopper Delay Board	21
Hot/Cold Switch	22
Lamp Holder	23
Lamp	23
Lamp Starter and Socket	24
Level Control Board and Level Probe	24
Limit Thermostat	26
Overflow Protection Switch	27
Rinse/Run Switch	28
Solenoid (Cold Drink - Optional)	29
Solenoid (Dispense)	30
Solenoid (Inlet)	31
Tank Heater	32
Tank Heater Switch	33
Whipper Motor	19
Wiring Diagrams	35 & 36

AUGER DRIVE COMPONENTS

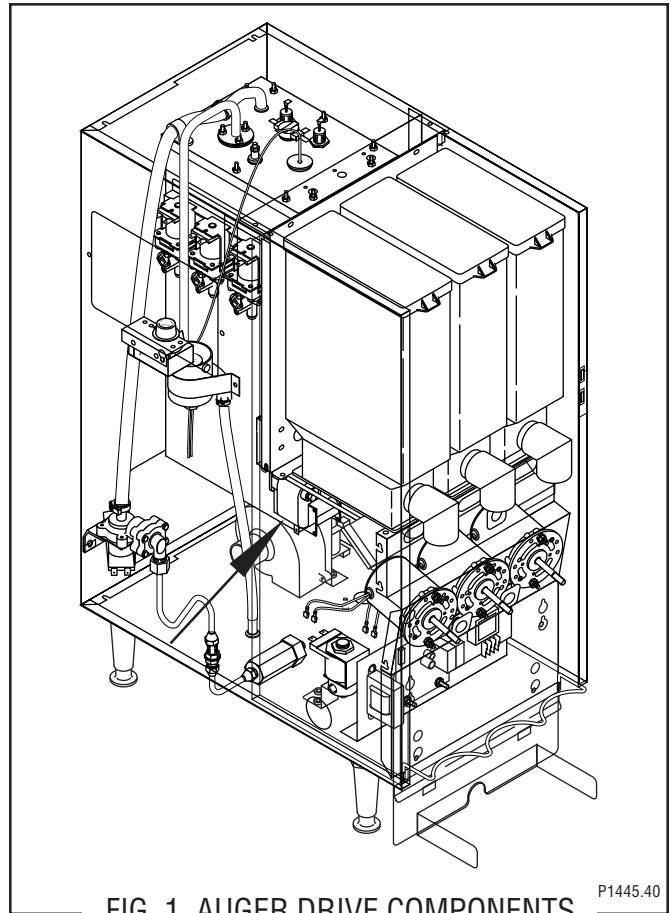

FIG. 1 AUGER DRIVE COMPONENTS

P1445.40

Location

The auger components are located inside the bottom part of the hopper except for the auger drive bracket, washer and locknut, which are located on the outside bottom rear of the hopper. The auger motors are located on the rear of the auger motor mounting panel. Refer to Fig. 2 for disassembly and assembly.

Test Procedures - Auger motors

1. Disconnect the dispenser from the power source.
2. Disconnect the wires from the motor to be tested.
3. Check the voltage across the white/violet wire for the right motor, orange wire for the center motor or the red wire for the left motor and the gray wire with a voltmeter. With the rinse/run switch in the run position press and hold the appropriate dispense switch. Connect the dispenser to the power supply. After a .7 second delay the indication must be :
 - a) 120 volts ac for two wire 120 volt models.
 - b) 120 volts ac for three wire 120/208 volt or 120/240 volt models.
 - c) 240 volts ac for two wire 240 volt models.

SERVICE

AUGER DRIVE COMPONENTS (CONT.)

4. Disconnect the dispenser from the power supply.

If voltage is present as described, proceed to #5.
If voltage is not present as described, refer to the wiring diagrams and check the dispenser wiring harness.

5. With the wires removed from the motor to be tested. Check for continuity across the two terminals on the bottom of the auger motor.

If continuity is present as described, reconnect the wires to the terminals on the bottom of the auger motor, the auger motor is operating properly.

If continuity is not present as described, replace the auger motor.

Removal, Cleaning and Replacement

Hopper & Auger

1. Open the dispenser door and raise the top front cover.
2. Lift the front edge of hopper assy (21) over the tab on hopper support plate (20) and slide hopper assembly out the front of the dispenser.
3. Remove hopper lid (1) and empty product.
4. Pull off the ejector elbow (14).
5. Remove auger disc assy (2) by pulling agitator support rod (4) towards agitator disc assy and lifting agitator disc assy from hopper (10).
6. Remove auger (12) by pulling it out the front of the hopper (10).
7. Remove auger drive shaft (5) by removing the retaining clip (6) from auger drive shaft.
8. Slide washer (8) and auger drive shaft bracket (7) off of the auger drive shaft (5).
9. Slide auger drive shaft (5) from auger drive shaft bushing (3) and remove from hopper (10).
10. Remove locknut (9) from auger drive shaft bushing (3) and remove auger drive shaft bushing from hopper (10).
11. Wash components in a mild solution of dish detergent using a bristle brush when needed.
12. Rinse and dry each item thoroughly.
13. Check for damaged or broken components, replace any if necessary and reassemble hopper assy.

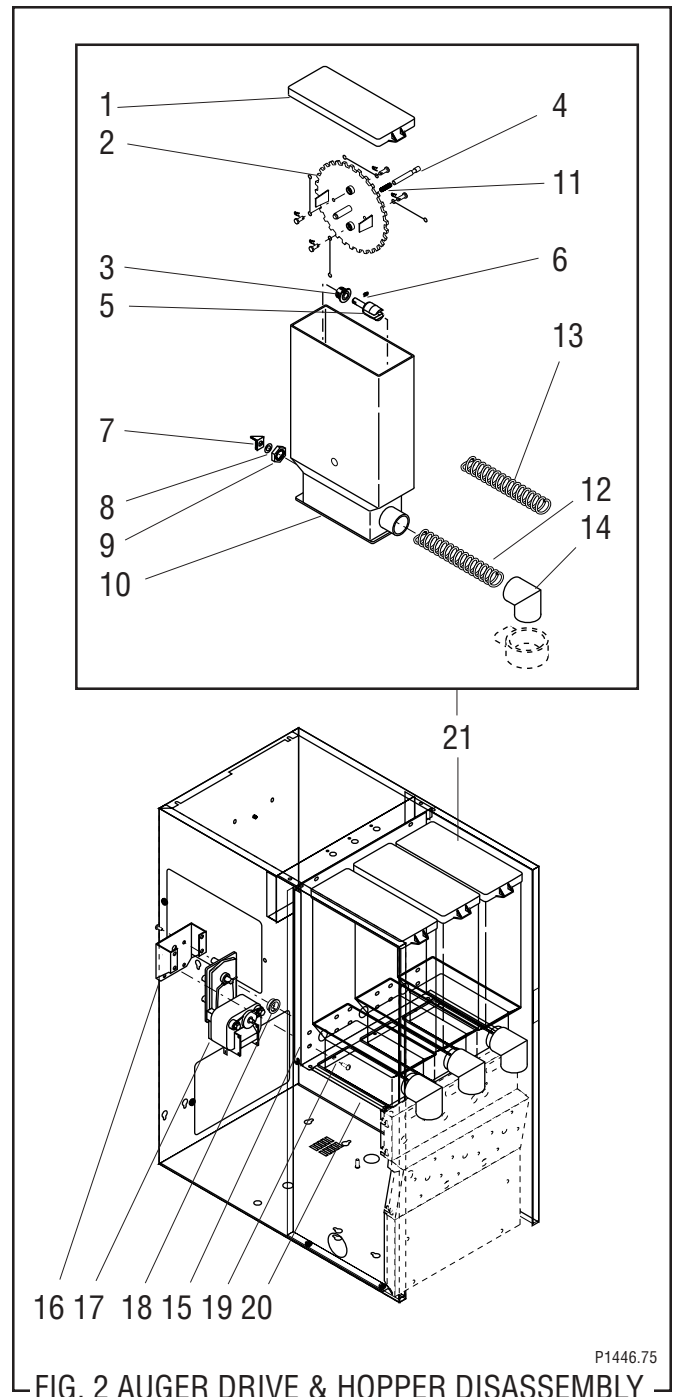

FIG. 2 AUGER DRIVE & HOPPER DISASSEMBLY

- | | |
|------------------------------|--------------------------------------|
| 1. Hopper Lid | 12. Auger Wire |
| 2. Agitator Disc Assy | 13. Auger Wire/Restrictor (Optional) |
| 3. Auger Drive Shaft Bushing | 14. Ejector Elbow |
| 4. Agitator Support Rod | 15. Auger Motor Mounting Panel |
| 5. Auger Drive Shaft | 16. Auger Motor Bracket |
| 6. Retainer Clip | 17. Auger Motor |
| 7. Auger Drive Bracket | 18. Dust Seal |
| 8. Washer | 19. Shoulder Screw |
| 9. Locknut | 20. Hopper Support plate |
| 10. Hopper | 21. Hopper Assy |
| 11. Spring | |

SERVICE (cont.)

AUGER DRIVE COMPONENTS (cont.)

14. Install hopper assy (21) in the dispenser by sliding hopper assy in the guides on the hopper support plate (20) until the slot in the bottom rear the hopper seats against the shoulder screw (19) in the hopper support plate.

Auger Drive Motor (Refer to Fig. 2)

1. Remove hopper assy (21) and set aside for reassembly.
2. Remove the the four #8-32 screws securing the hopper support plate (20), remove plate and set aside for reassembly.
3. Remove the four #8-32 locking screws, located inside the dispenser housing on the front of the auger motor mounting panel (15), securing auger motor mounting bracket (16) and auger motor (17) to the rear of the auger motor mounting panel (15).
4. Disconnect the wires from the auger motor (17) to be removed.
5. Remove auger motor mounting bracket (16), auger motor (17) and dust seal (18) as an assembly.
6. Remove dust seal (18) from auger motor (17).
7. Remove the four #8-32 screws securing the auger motor to the auger motor mounting bracket.
8. Remove auger motor and discard.
9. Using four #8-32 screw install new auger motor (17) on mounting bracket (16).
10. Install dust seal (18) on auger motor shaft.
11. Using four #8-32 locking screws install auger motor, dust seal and mounting bracket to the rear of the auger motor mounting panel (15)
12. Reconnect the wires to the terminals on the bottom of the auger motor.
13. Install hopper support plate (20) and hopper assembly (21).
14. Refer to Fig. 3 when reconnecting wires.

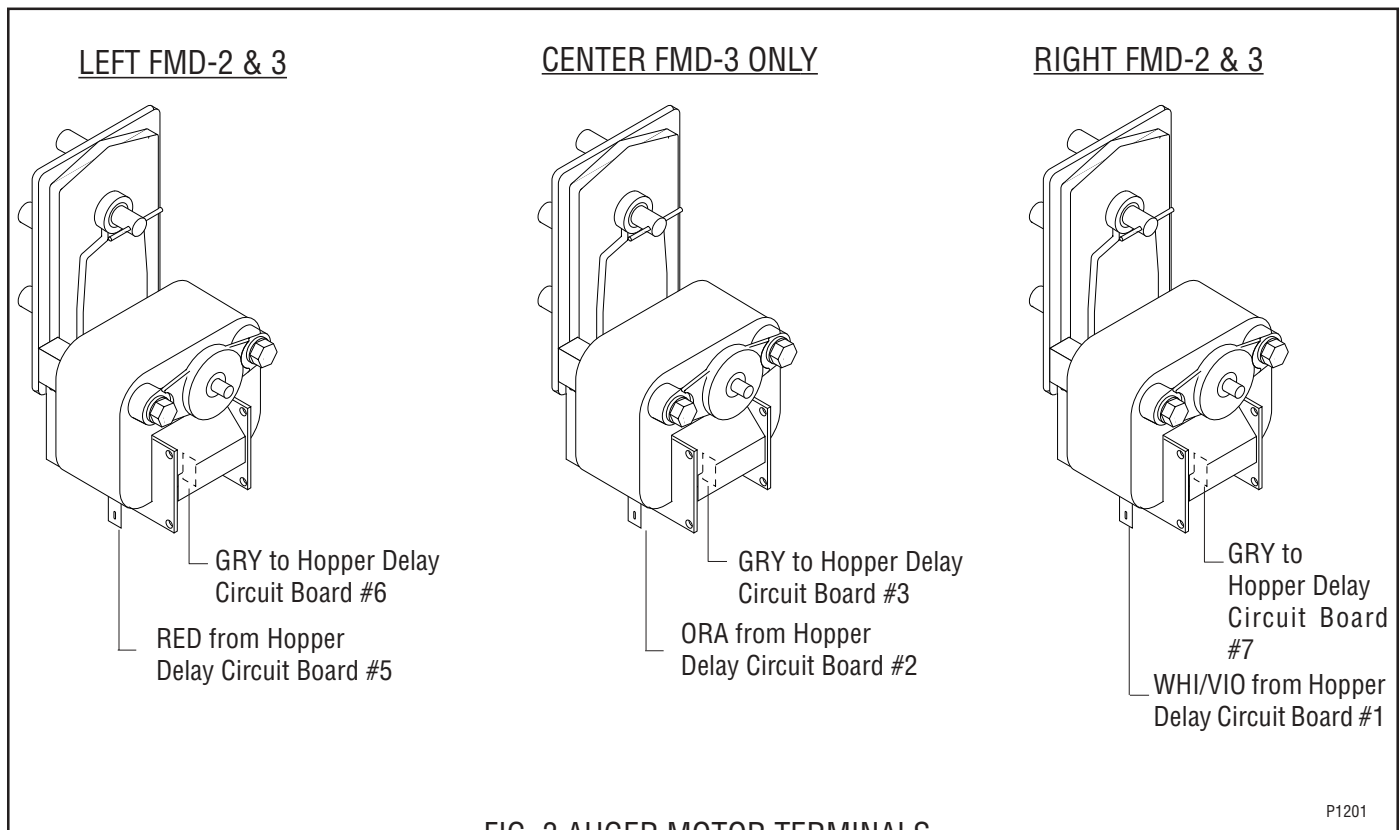

SERVICE (cont.)

BALLAST

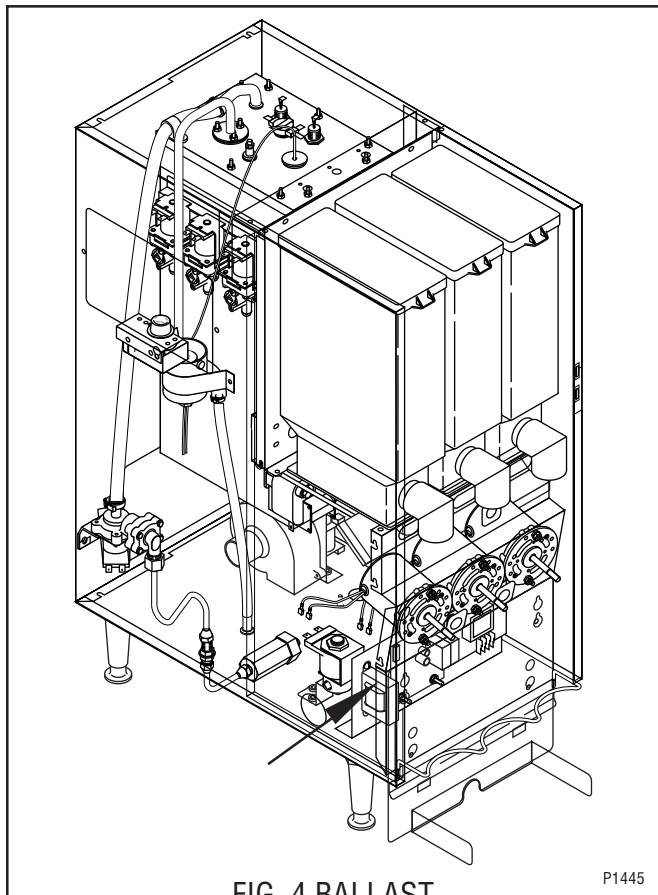

Location

The front door lamp ballast is located behind the front access panel on the left side of the component bracket.

Test Procedure

1. Disconnect the dispenser from the power source.
2. Disconnect the two terminal plug of the door interconnect harness from the main wiring harness.
3. Check the voltage across the white wire and the blue wire terminal of the ballast with a voltmeter. Connect the dispenser to power source. The indication must be:
 - a) 120 volts ac for two wire 120 volt models.
 - b) 120 volts ac for three wire 120/208 volt models or 120/240 volts models.
 - c) 240 volts ac for two wire 240 volt models.

If voltage is present as described the ballast is operating properly.

If voltage is not present as described, replace the ballast.

Removal and Replacement

1. Disconnect the wires from the ballast.
2. Remove the one #8-32 screw securing the ballast to the component bracket.
3. Remove and discard ballast.
4. Install new ballast over the weld pin on the component bracket and secure with one #8-32 screw.
5. Refer to Fig. 5 when reconnecting the wires.

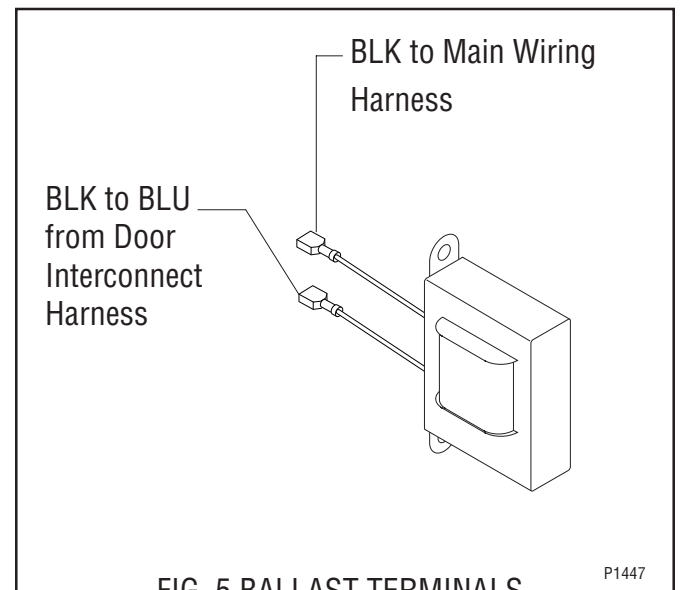

SERVICE (cont.)

CONTROL THERMOSTAT

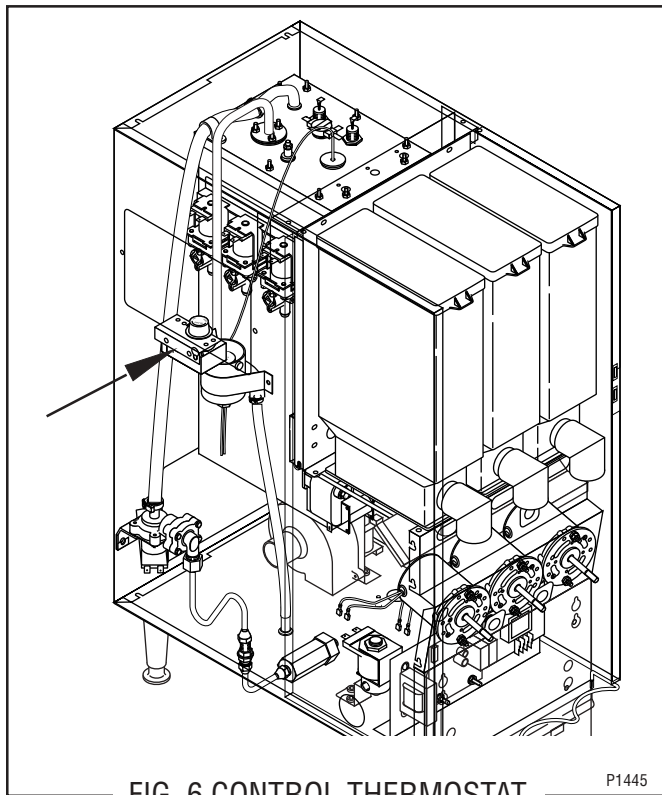

FIG. 6 CONTROL THERMOSTAT

Location

The control thermostat (mechanical or electronic) is located inside the dispenser on the upper left side of the housing.

Test Procedure

Mechanical Thermostat

1. Disconnect the dispenser from the power source.
2. Disconnect the black wire of the control thermostat from the black lead from the limit thermostat.
3. Remove bulb from the tank.
4. Check the voltage across black wire on the control thermostat and the white or red wire on the tank heater with the tank heater switch in the "ON" lower position with a voltmeter. Connect the dispenser to the power source. The indication must be:
 - a) 120 volts ac for two wire 120 volt models.
 - b) 208 volts ac for three wire 120/208 volt or 240 volts ac for 120/240 volt models.
 - c) 240 volts ac for two wire 240 volt models.
5. Disconnect the dispenser from the power source.

If voltage is present as described the control thermostat is operating properly. Reinstall bulb into the tank. If voltage is not present as described, replace the thermostat.

Electronic Thermostat (Optional)

1. Disconnect the dispenser from the power source.
2. Disconnect the black wire of the control thermostat from the black wire from the limit thermostat.
3. Remove temperature probe from the tank.
4. Check the voltage the black wire from the control thermostat and the white or red wire on the tank heater with the tank heater switch in "ON" lower position with a voltmeter. Connect the dispenser to the power source. The indication must be:
 - a) 120 volts ac for two wire 120 volt models.
 - b) 120 volts ac for three wire 120/208 volt or 120/240 volt models.
 - c) 240 volts ac for two wire 240 volt models.

If voltage is present as described the control thermostat is operating properly. Reinstall temperature probe into the tank.

If voltage is not present as described, replace the control thermostat.

Removal and Replacement.

1. Disconnect the wires from the thermostat.
2. Remove the thermostat capillary bulb by firmly pulling-up on the capillary at the tank lid. This will disengage the grommet from the tank lid.
3. Loosen the two #8-32 screws securing the thermostat bracket to the upper left rear of the dispenser housing.
4. Remove thermostat bracket and thermostat as an assembly.
5. Remove the two #6-32 screws securing the thermostat to the thermostat bracket and discard thermostat.
6. Install new thermostat on the thermostat bracket using two #6-32 screws.
7. Install the thermostat and bracket inside the dispenser housing on the upper left rear side and tighten the two #8-32 screws.
8. Slide the grommet to the line 4.5" above the bulb on the new capillary tube.
9. Insert the capillary bulb through the hole in the tank lid and press the grommet firmly and evenly so that the groove in the grommet fits into the tank lid.

SERVICE (cont.)

CONTROL THERMOSTAT (cont.)

10. Carefully bend the capillary tube so that the tube and bulb inside the tank are in the vertical position and away from any electrical connections.

11. Refer to Fig. 7 and reconnect the wires.

NOTE - The capillary tube must be clear of any electrical termination and not kinked.

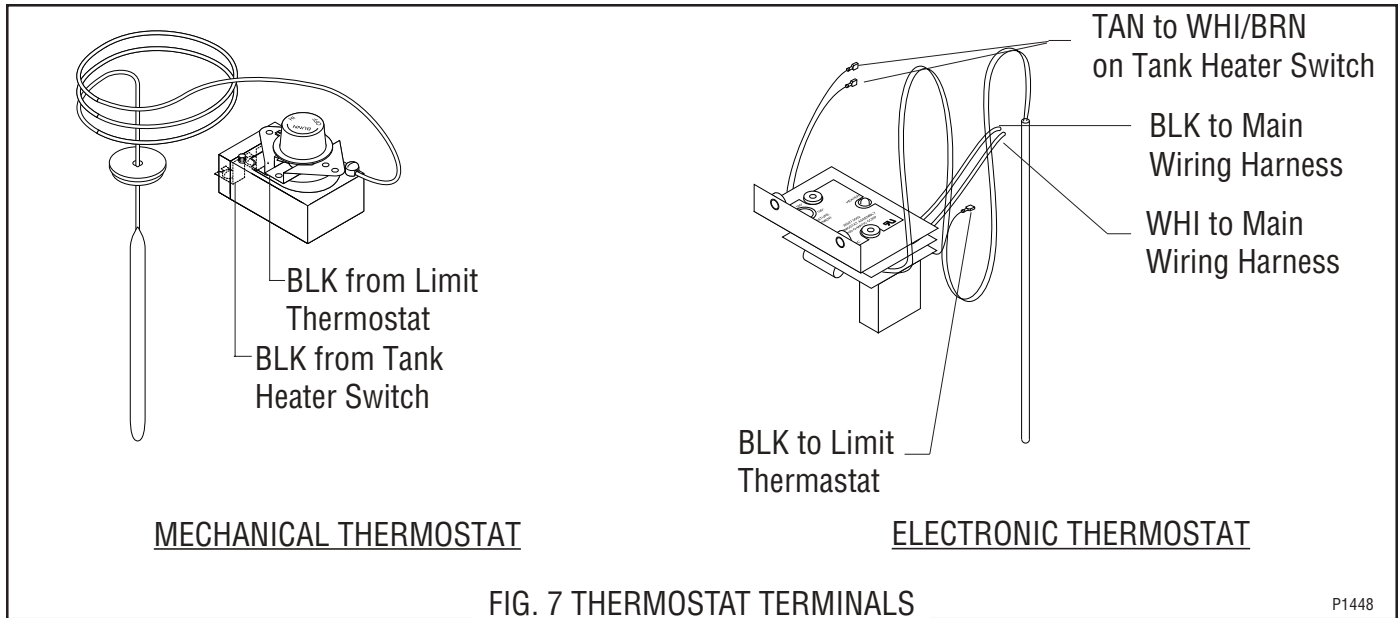

DISPENSE SWITCH

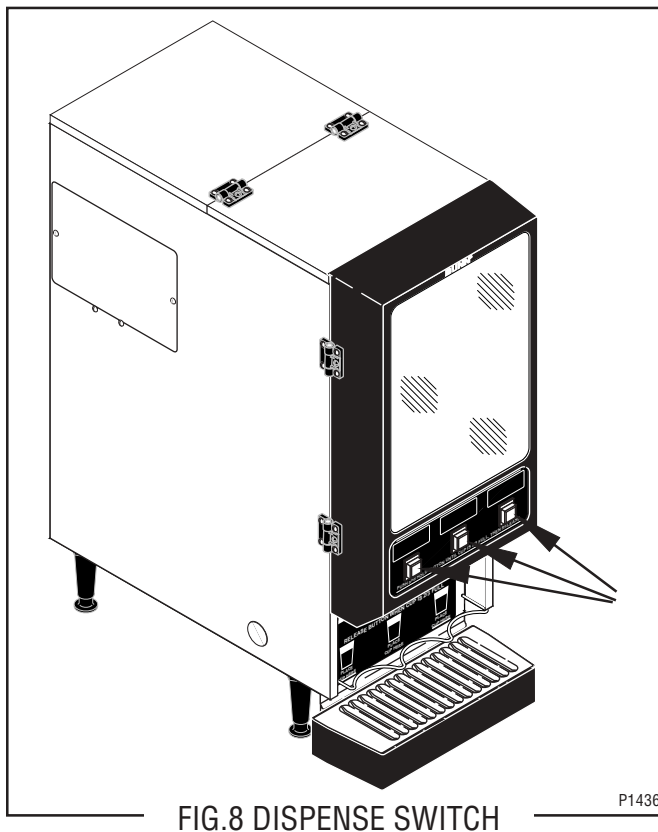

Location:

The dispense switches are located on the lower outside of the dispenser door.

NOTE: The center dispense switch is for FMD-3 Models only.

Test Procedure:

1. Disconnect the dispenser from the power source.
2. Open the dispenser door and remove the bottom door cover.
3. Disconnect the wires from the door interconnect wiring harness to the dispense switch to be tested.
4. Check for voltage across the black and red/black wires for the right dispense switch, black and red/white wires for the center dispense switch or the black and red wires for the left dispense switch from the door interconnect wiring harness. Connect the dispenser to the power supply. The indication must be:
 - a) 120 volts ac for two wire 120 volt models.
 - b) 120 volts ac for three wire 120/208 volt or 120/240 volt models.
 - c) 240 volts ac for two wire 240 volt models.
5. Disconnect the dispenser from the power source.

If voltage is present as described, proceed to #6. If voltage is not present as described, refer to the wiring diagram and check the dispenser wiring harness.

SERVICE (cont.)

DISPENSE SWITCH (cont.)

6. Check for continuity across the terminals on the dispense switch with the switch in the "ON" pressed position. Continuity must not be present when the switch is in the "OFF" released position.

If continuity is present as described, reconnect the connector to the door interconnect wiring harness, the switch is operating properly.

If continuity is not present as described, replace the switch.

Removal and Replacement

1. Open the dispenser door.
2. Remove the five #6-32 screws securing the bottom door cover and remove cover.
3. Disconnect the wires on the dispense switch to be removed from the door interconnect wiring harness.
4. Compress the clips inside the door on the dispense switch and gently push the switch through the opening.
5. Push new switch into the opening and spread the clips to hold the switch in the door.
6. Reconnect the wires to the dispense switch from door interconnect wiring harness.
7. Reinstall the door bottom cover using five #6-32 screws.
8. Refer to Fig. 9 when reinstalling wires.

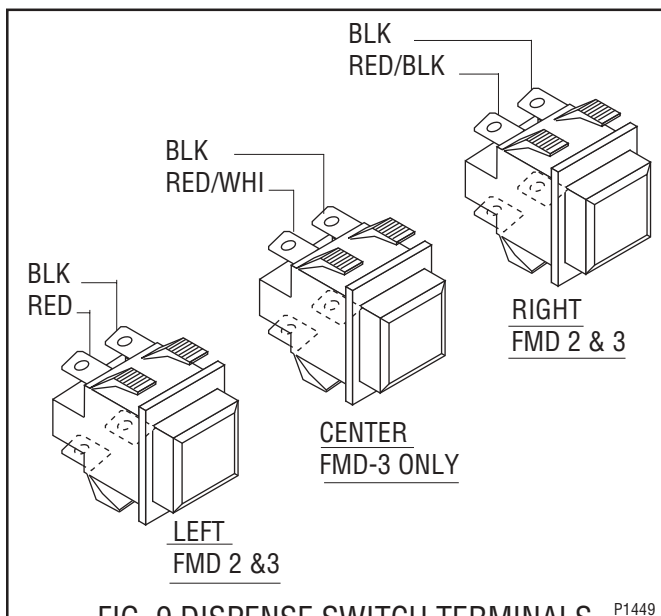
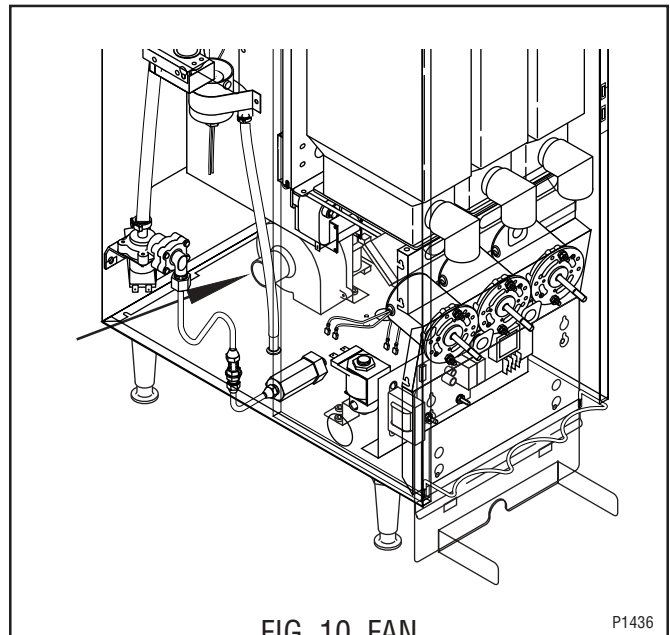

FIG. 9 DISPENSE SWITCH TERMINALS P1449

FAN



Location:

The fan is located inside the dispenser housing on the right rear of the dispenser base plate.

Test Procedures:

1. Disconnect the dispenser from the power source.
2. Disconnect the black and white wires from the fan terminals.
3. Check the voltage across the black and white wires with a voltmeter. Connect the dispenser to the power source. The indication must be:
 - a) 120 volts ac for two wire 120 volts models.
 - b) 120 volts ac for three wire 120/208 volt or 120/240 volt models.
 - c) 240 volts ac for two wire 240 volt models.

If voltage is present as described, replace the fan. If voltage is not present as described, refer to wiring diagram and check the dispenser wiring harness.

Removal and Replacement:

1. Disconnect the vacuum hose from the fan.
2. Remove the two #8-32 locking screws securing the fan to the dispenser housing base plate.
3. Disconnect the wires from the fan terminals and discard the fan.
4. Refer to Fig. 11 and connect the wires to the new fan.
5. Install new fan through the rear access hole and secure to the dispenser housing base plate using two #8-32 locking screws.

SERVICE (cont.)

FAN (cont.)

6. Reconnect the vacuum hose to the fan.

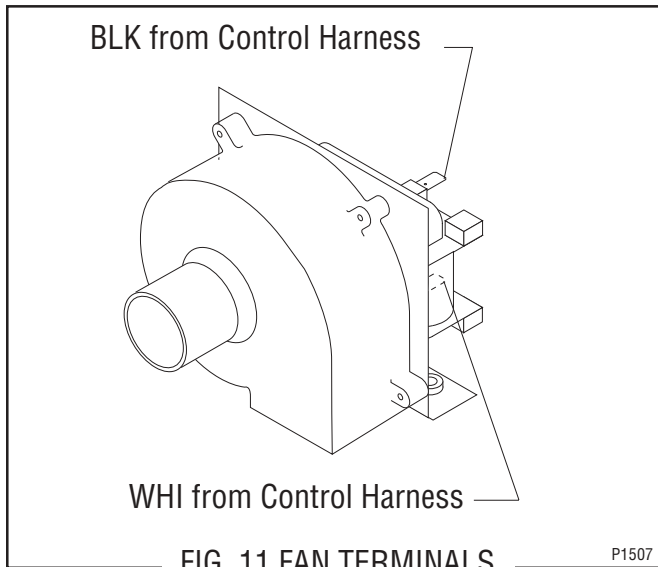

FROTHER AND WHIPPER MOTOR

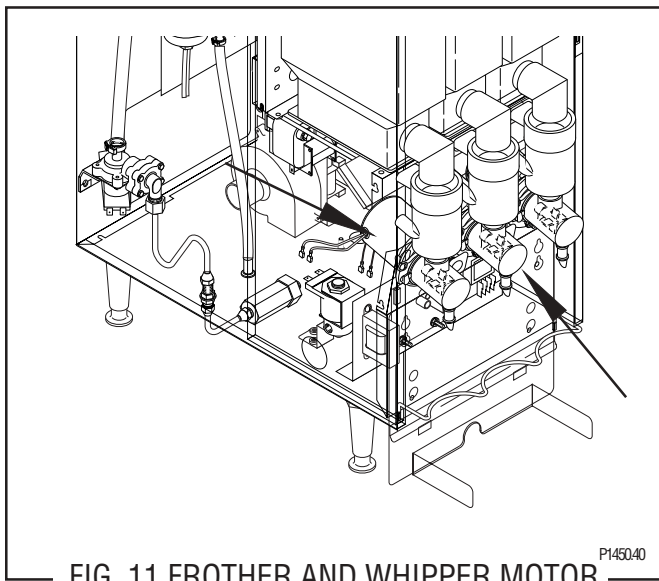

Location:

The frothers are located behind the dispenser door, mounted on the whipper motor shaft inside the whipper chamber.

The whipper motors are located on the back side of the whipper motor mounting panel.

NOTE: The center position is for FMD-3 Models only.

Test Procedure:

1. Disconnect the dispenser from the power source.
2. Disconnect the white/violet and white wires on the right motor, orange and white wires on the center motor or the red and white wires on the left motor from the black leads on the motors.

3. Press and hold the appropriate dispense switch and check the voltage across the disconnected harness wires with a voltmeter. Connect the dispenser to the power source. The reading must be:
 - a) 120 volts ac for two wire 120 volt models.
 - b) 120 volts ac for three wire 120/208 volt or 120/240 volt models.
 - c) 240 volts ac for two wire 240 volt models.
4. Disconnect the dispenser from the power source.

If voltage is present as described, replace the motor. If voltage is not present as described, refer to the wiring diagrams and check the dispenser wiring harness.

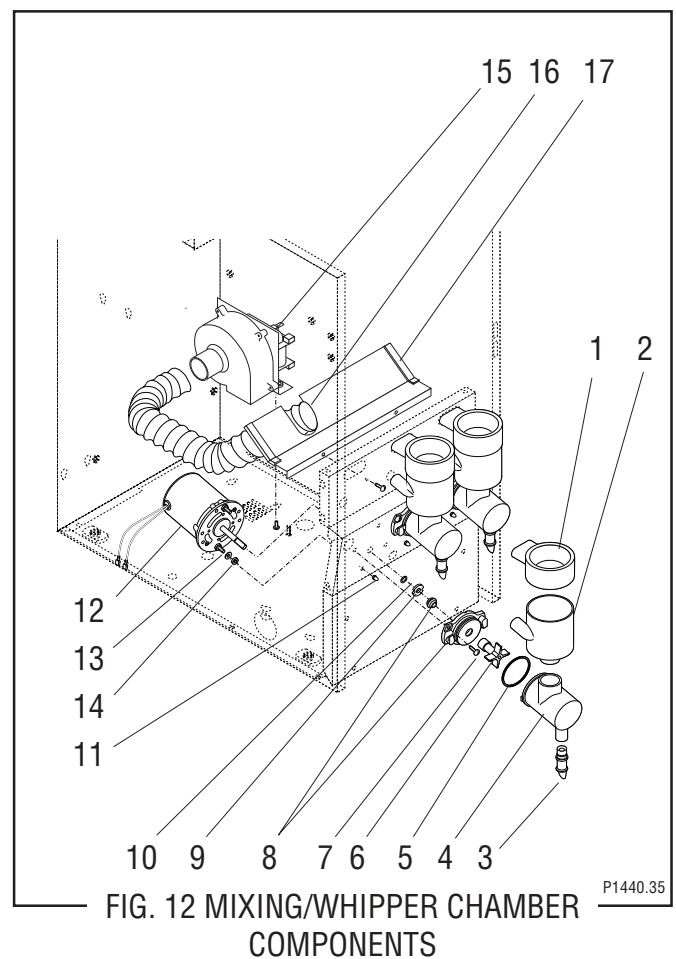

- | | |
|----------------------|---------------------|
| 1. Steam Collector | 10. O-Ring |
| 2. Mixing Chamber | 11. #8-32 Acorn Nut |
| 3. Dispense Tip | 12. Motor Assy. |
| 4. Whipper Chamber | 13. Washer |
| 5. O-Ring | 14. Nut |
| 6. Frother | 15. Fan |
| 7. #6-32 Screw | 16. Vacuum Hose |
| 8. Receptical w/Seal | 17. Baffle |
| 9. Teflon Washer | |

SERVICE (cont.)

FROTHER AND WHIPPER MOTOR (cont.)

Removal, Cleaning and Replacement (Refer to Fig. 12):

1. Open the dispenser door and raise the top front cover.
2. Lift the front edge of the each hopper assembly over the tab on the hopper support panel and slide each hopper assembly out the front of the dispenser. Set aside for reassembly.
3. Remove the four #8-32 screws securing the hopper support panel to auger motor mounting panel and the whipper motor mounting panel. Set aside for reassembly.
4. Disconnect vacuum hose (16) from fan baffle (17).
5. Remove the two #4-40 x .25" screws securing the fan baffle(17) to the whipper motor mouting panel and remove fan baffle. Set aside for reassembly.
6. Remove the steam collector (1) by pulling it forward and at the same time twisting it clockwise.
7. Pull the mixing chamber (2) out of the whipper chamber (4).
8. Remove dispense tip (3) and twist the whipper chamber (4) clockwise and pull it off the whipper chamber receptacle (8).
9. Pull the frother (6) off the motor shaft. Notice the flat side on the shaft and the matching flat inside the frother. It is important that these two flats are lined up when reassembling.
10. Slip the o-ring (5) off the whipper chamber receptical (8).
11. Remove the two #6-32 screws (7) securing whipper chamber receptical (8) to the front panel.
12. Slide the receptical w/seal off of the motor shaft.
13. Slide teflon washer (9) and o-ring (10) off of the motor shaft.
14. Disconnect the black leads on the motor (12) from the main wiring harness.
15. Remove the two #8-32 acorn nuts (11) securing the motor (12) to the rear of front panel.
16. Remove motor and discard.
17. Install new motor (12) on rear of front panel and secure with two #8-32 acorn nuts (11) and connect black leads on the motor to the main wiring harness. Refer to FDig. 13 when reconnecting wires
18. Slide o-ring (10) onto the motor shaft to approximately 1/16" of the front panel.
19. Wash remaining components in a mild solution of dish detergent using a bristle brush.
20. Rinse thoroughly and allow to dry before reinstalling in the dispenser.
21. Place teflon washer into back opening of whipper chamber receptical and align one notch with bump in the opening.
22. Slide whipper chamber receptacle w/seal on to the motor shaft and secure to the front panel using two #6-32 screws (7).
23. Slip o-ring (5) onto the whipper chamber receptical (8).
24. Push frother (6) onto the motor shaft, making sure the flat in the frother (6) lines up with the flat on the motor shaft.
25. Install whipper chamber (4) on the whipper chamber receptical (8) by twisting counterclockwise until the tabs on the whipper chamber (4) lock with the tabs on the whipper chamber receptical (8). Be sure dispense port is pointing down.
26. Install dispense tip (3) into the bottom of the whipper chamber (4). Be sure the cutout part of the dispense tip is facing the outside of the dispenser.
27. Using two #4-40 screws secure the fan baffle to the to the whipper motor mounting panel.
28. Install vacuum hose (16) on fan baffle (17).
29. Install hopper support panel using four #8-32 screws.
30. Slip the mixing chamber (2) onto the mixing chamber water inlet tube far enough so the mixing chamber (2) will seat inside the whipper chamber (4).
31. Install the steam collector (1) onto the mixing chamber (2) by pushing down and toward the dispenser while twisting until the flange on the steam collector lines-up with the slot in the front panel.
32. Install hopper assembly in the dispenser by sliding hopper assembly on the hopper support panel until the slot in the bottom rear of the hopper seats against the shoulder screw in the hopper support panel.

SERVICE (cont.)

FROTHER AND WHIPPER MOTOR (cont.)

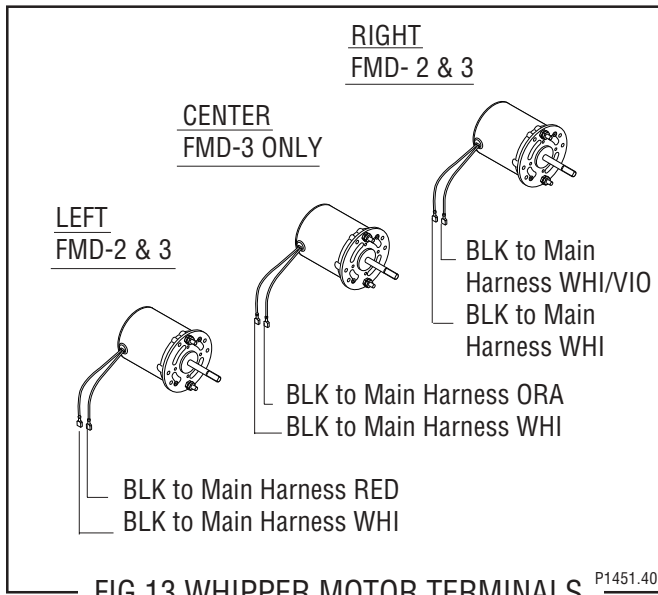

HOPPER DELAY BOARD

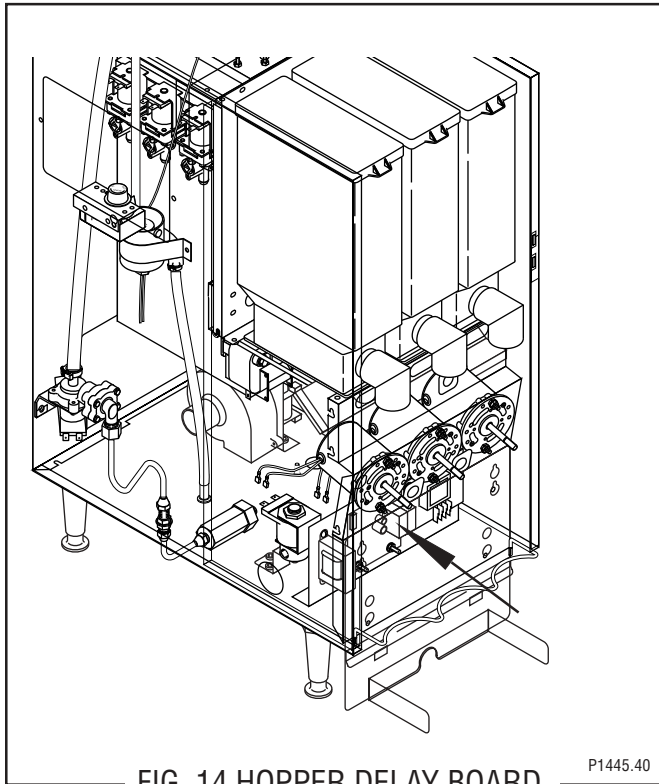

Location

The hopper delay board is located behind the lower front access panel mounted in the center of the component bracket.

Test Procedures:

1. Disconnect the dispenser from the power source.
2. Disconnect the eight pin plug on the main wiring harness from the eight pin connector on the hopper delay board.
3. With the rinse/run switch in the "Run", lower position, check the voltage across the white and black wires of the main wiring harness with a voltmeter. Connect the dispenser to the power source. The indication must be:
 - a) 120 volts ac for two wire 120 volt models.
 - b) 120 volts ac for three wire 120/208 volt or 120/240 volt models.
 - c) 240 volts ac for two wire 240 volt models.
4. Disconnect the dispenser from the power source.

If voltage is present as described, proceed to #5. If voltage is not present as described, refer to the wiring diagram and check the dispenser wiring harness.

5. Reconnect the eight pin connector of the hopper delay board to the main harness.
6. Check the voltage across the terminals on the auger motor with a voltmeter. Press and hold the appropriate dispense switch. Connect the dispenser to the power source. After a delay of .7 seconds the indication must be:
 - a) 120 volts ac for two wire 120 volt models.
 - b) 120 volts ac for three wire 120/208 volt or 120/240 volt models.
 - c) 240 volts ac for two wire 240 volt models.
7. Disconnect the dispenser from the power source.

If voltage is present as described the hopper delay board is operating properly.

If voltage is not present as described, replace the hopper delay board.

Removal and Replacement:

1. Disconnect the eight pin plug from the hopper delay board.
2. Remove the two #8-32 keps nuts securing the hopper delay board to the component bracket.
3. Remove hopper delay board and discard.
4. Install new delay board on the component bracket using two #8-32 keps nuts.
5. Reconnect the eight pin connector to the hopper delay board.

SERVICE (cont.)

HOT/COLD SWITCH (Optional)

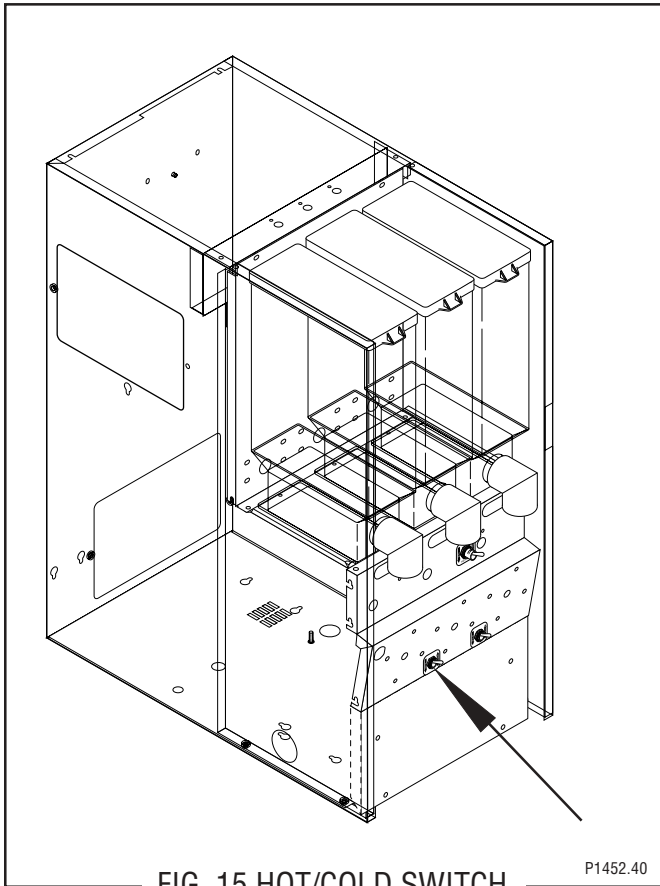

FIG. 15 HOT/COLD SWITCH

Location:

The hot/cold switch is located on the left side of the whipper motor mounting panel.

Test Procedure:

1. Disconnect the dispenser from the power source.
2. Disconnect the four pin plug from the hot/cold switch and the four pin connector on the main wiring harness.
3. Press the left dispense switch on the door and check the voltage across the white wire (P4) and red wire (P2) in the four pin connector on the main wiring harness with a voltmeter. Connect the dispenser to the power source. The indication must be:
 - a) 120 volts ac for two wire 120 volt models.
 - b) 120 volts ac for three wire 120/208 volt or 120/240 volt models.
 - c) 240 volts ac for two wire 240 volt models.
4. Disconnect the dispenser from the power source.

If voltage is present as described, reconnect the four pin plugs and proceed to #5.

If voltage is not present as described, refer to the wiring diagram and check the main wiring harness.

5. Disconnect the wires from the switch terminals.
6. With the switch in the upper "Cold" position check for continuity between the center terminal and the bottom terminal. With the switch in the down "Hot" position check for continuity between the center terminal and the upper terminal.

If continuity is present as described, the hot/cold switch is operating properly.

If continuity is not present as described, replace the switch.

Removal and Replacement:

1. Remove all wires from the switch terminals.
2. Remove the mounting nut on the front of the whipper motor mounting panel.
3. Remove the hot/cold switch from the rear of the front panel and discard.
4. Reconnect the wires to the terminals on the rear of the new switch.
5. Push new hot/cold switch through the hole on the left side of the whipper motor mounting panel and secure with mounting nut.
6. Refer to Fig. 16 when reconnecting the wires.

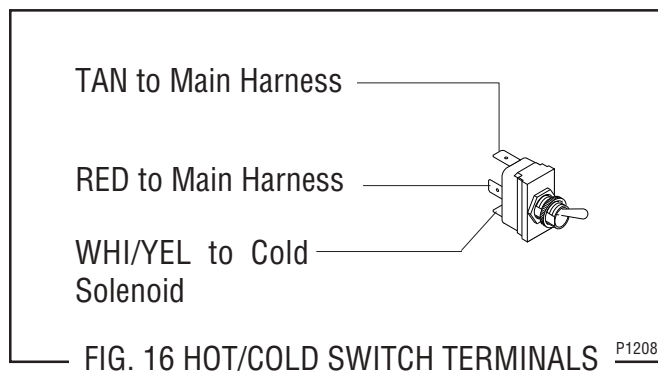
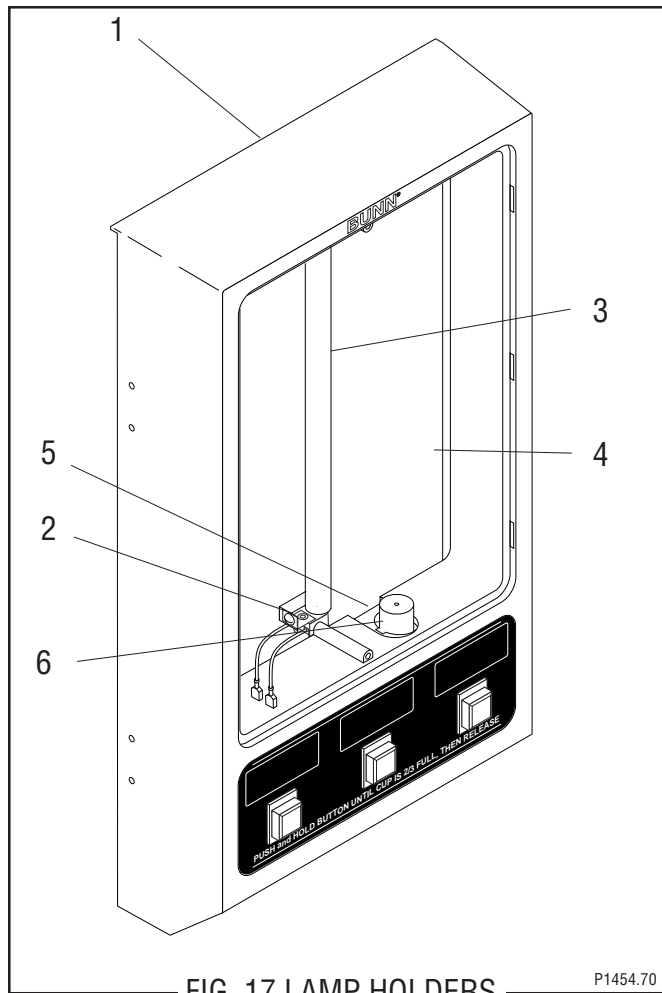

FIG. 16 HOT/COLD SWITCH TERMINALS

SERVICE (cont.)

LAMP HOLDER



- | | |
|-----------------|---------------------|
| 1. Door Assy | 4. Upper Panel |
| 2. Lamp Holders | 5. Lower Panel |
| 3. Lamp | 6. Starter W/Socket |

Location:

The lamp holders are located on the front of the upper panel behind the display panel.

Test Procedure:

1. Disconnect the dispenser from the power source.
2. Remove upper door panel (4) and disconnect the door wiring harness from the leads on the lamp holders.
3. Remove lamp from lamp holders.
4. Check for continuity on each lead of the lamp holders.

If continuity is present as described, lamp holders are operating properly.

If continuity is not present as described replace the lamp holder.

Removal and Replacement:

1. Open dispenser door (1).
2. Remove the five #6-32 screws securing lower door panel (5) to the door (1) and remove cover.
3. Disconnect the door wiring harness from the door interconnect wiring harness.
4. Remove five #6-32 screws securing the upper door panel (4) to the door.
5. Remove the upper door cover (4), lamp (3), lamp holders (2) and door wiring harness as an assembly.
6. Disconnect the wires from the lamp holder to be replaced from the door wiring harness.
7. Rotate lamp (3) 90° and remove from lamp holders (2).
8. Remove the #6-32 screw securing the lamp holder (2) to be removed, remove lamp holder (2) and discard.
9. Install new lamp holder (2) and secure with a #6-32 screw.
10. Connect the wires on the new lamp holder to the door wiring harness.
11. Install lamp (3) into lamp holders (2) and turn 90° until the pins snap in place.
12. Install upper door panel (4), lamp (3), lamp holders (2) and door wiring harness as a assembly using five #6-32 screws.
13. Reconnect the plug on the door wiring harness to the connector on the door interconnect wiring harness.
14. Install the door lower panel (5) using five #6-32 screws.

LAMP REPLACEMENT (Refer to Fig. 17)

1. Remove the outside window and display graphic.
2. Remove the two #4-40 screws securing the inside window to the door and remove window.
3. Rotate lamp (3) 90° and remove from the lamp holders (2).
4. Insert new lamp (3) into lamp holders (2) and turn 90° until the pins snap in place.
5. Using two #4-40 screws secure the inside window to the door.
6. Install outside window and slide display graphic down between the inside window and the outside window.

SERVICE (cont.)

LAMP STARTER and SOCKET

Location:

The lamp starter (6) is located inside the door assy (1) on the top of the door lower panel (5).

Test Procedures:

1. Disconnect the dispenser from the power source.
2. Disconnect the starter leads from the door wiring harness.
3. Remove lamp starter from starter socket.
4. Check for continuity on each lead of the starter socket.

If continuity is present as described the starter socket is operating properly.

If continuity is not present as described replace the the starter socket.

6. Remove starter (6) from starter socket.
7. Check for continuity across the pins on the bottom of the starter (6).

If continuity is present as described , replace the starter.

If continuity is not present as described, starter is operating properly.

Note: If continuity tests are both as described and lamp does not light, replace the starter socket.

Removal and Replacement (Refer to Fig.17):

1. Open dispenser door assy (1)
2. Remove the five #6-32 screws securing the door lower panel (5) to the door assy (1).
3. Disconnect the leads on the starter socket from the door wiring harness.
4. Remove lower door panel (5) and starter w/socket (6) as assembly.
5. Compress the spring tabs on the socket and remove socket from the door bottom cover (5).
6. Rotate starter 90° and remove from the starter socket.
7. Insert new starter (6) into socket and turn 90° until the pins snap in place.
8. Install new socket by compressing spring tabs on the socket and pushing the socket up through the hole in the lower door panel (5) and releasing spring tabs.

9. Connect the sockets leads to the door wiring harness.
10. Install door lower panel (5) with starter and starter socket on door assy (1) using five #6-32 screws.

LEVEL CONTROL BOARD AND LEVEL PROBE

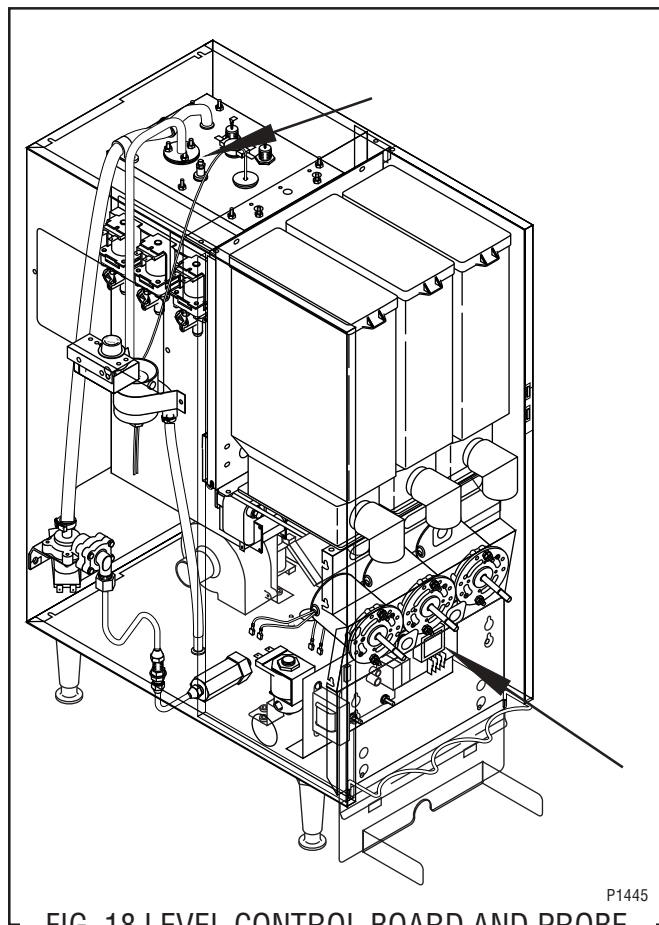

FIG. 18 LEVEL CONTROL BOARD AND PROBE

Location:

The level control board is located behind the lower access panel mounted on the right side of the component bracket.

The Level probe is located on the left center of the tank lid just in front of the overflow tube.

Test Procedure:

1. Disconnect the dispenser from the power source.
2. Remove the violet wire from terminal 1 & pink wire from terminal 4 of the circuit board.
3. Check the voltage across terminals 2 & 3 with a voltmeter. Connect the dispenser to the power source. The indication must be 120 volts ac for two wire 120 volt models, three wire 120/208 volt models, three wire 120/240 volt models and 240 volts ac for two wire 240 volt models.
4. Disconnect the dispenser from the power source.

SERVICE (cont.)

LEVEL CONTROL BOARD AND LEVEL PROBE (cont.)

If voltage is present as described, proceed to #5.
If voltage is not present as described, refer to the wiring diagram and check the dispenser wiring harness.

5. Reconnect the violet wire to terminal 1.
6. Carefully connect a piece of insulated jumper wire to terminal 4. Keep the other end of this wire away from any metal surface of the dispenser.
7. Check the voltage across terminals 1 & 3 with a voltmeter. Connect the dispenser to the power source. The indication must be 120 volts ac for two wire 120 volt models, three wire 120/208 volt models, three wire 120/240 volt models and 240 volts ac for two wire 240 volt models after a delay of approximately 5 seconds.
8. Touch the free end of jumper wire to the dispenser housing. The indication must be 0.
9. Move the jumper wire away from the dispenser housing. The indication must again be 120 volts ac for two wire 120 volt models, three wire 120/208 volt models, three wire 120/240 volt models and 240 volts ac for two wire 240 volt models after a delay of approximately 5 seconds.
10. Disconnect the dispenser from the power source and remove the jumper wire from terminal 4.

If voltage is present as described, the level control board is operating properly, proceed to #11.
If voltage is not present as described, replace the level control board.

11. Reconnect the pink wire to terminal 4.
12. Gently pull the probe out of the tank lid and inspect for corrosion. Replace it if necessary.
13. Place the probe so that neither end is in contact with any metal surface of the dispenser.
14. Check the voltage across terminals 1 & 3 with a voltmeter. Connect the dispenser to the power source. The indication must be 120 volts ac for two wire 120 volt models, three wire 120/208 volt models, three wire 120/240 volt models and 240 volts ac for two wire 240 volt models after a delay of approximately 5 seconds.
15. Move the probe's flat end to the dispenser housing. The indication must be 0.

16. Move the probe's flat end away from the dispenser housing. The indication should again be 120 volts ac for two wire 120 volt models, three wire 120/208 volt models, three wire 120/240 volt models and 240 volt ac for two wire 240 volt models after a delay of approximately 5 seconds.

If voltage is present as described, reinstall the probe, the level control board and level probe are operating properly.

If voltage is not present as described, check the pink probe wire for continuity.

Removal and Replacement:

1. Remove all wires from the level control board.
2. Remove two #8-32 keps nuts holding level control board to right side of the component bracket.
3. Remove level control board and spacers.
3. Install the new level control board and spacers to the right side of the component bracket using two #8-32 keps nuts.
4. Refer to Fig. 19 when reconnecting the wires.

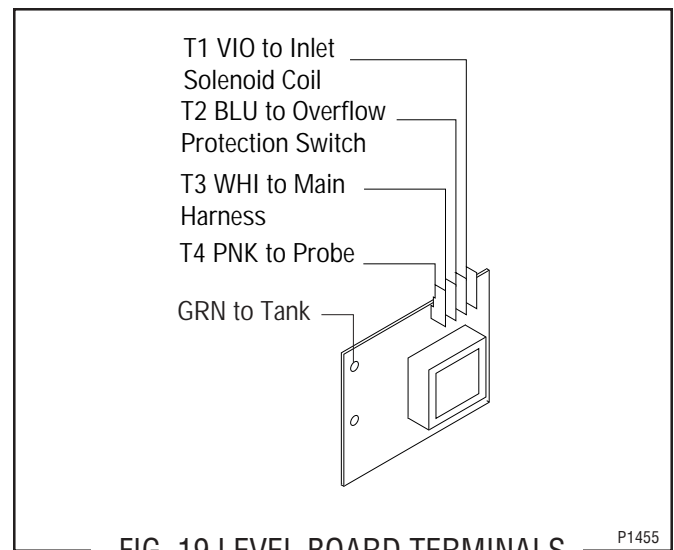

FIG. 19 LEVEL BOARD TERMINALS

P1455

SERVICE (cont.)

LIMIT THERMOSTAT

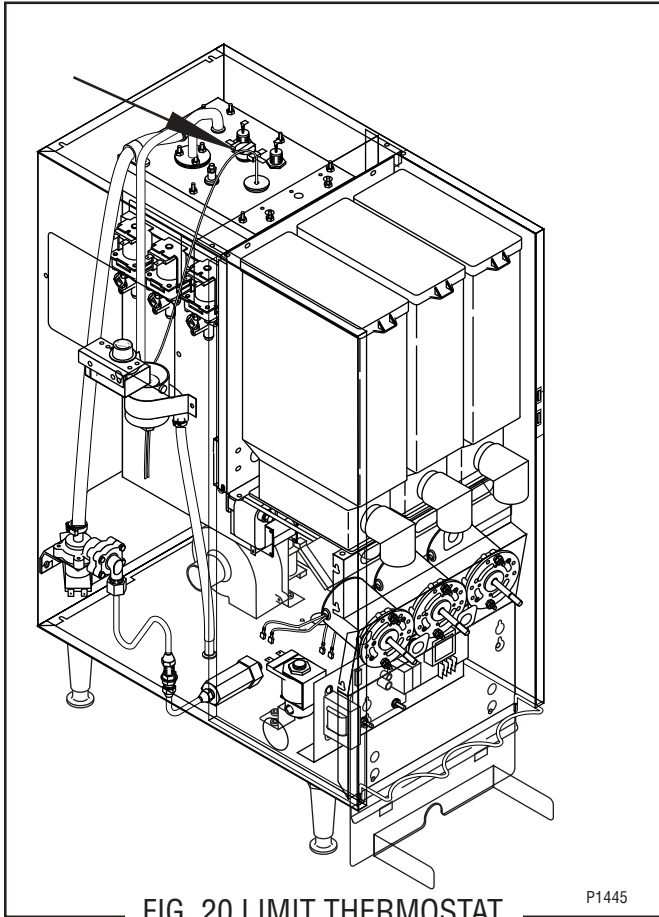

FIG. 20 LIMIT THERMOSTAT

P1445

Location:

The limit thermostat is located in the center of the tank lid.

Test Procedures:

1. Disconnect the dispenser from the power source.
2. Disconnect both black wires from the limit thermostat.
3. Check for continuity across the limit thermostat terminals.

If continuity is present as described, the limit thermostat is operating properly.

If continuity is not present as described, replace the limit thermostat.

Removal and Replacement:

1. Remove all wires from the limit thermostat terminals.
2. Carefully slide the limit thermostat out from under the retaining clip and remove the limit thermostat.
3. Carefully slide the new limit thermostat into the retaining clip.
4. Refer to Fig. 21 when reconnecting the wires.

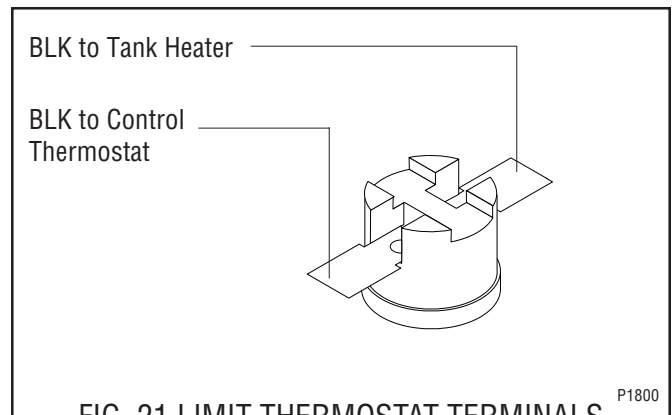

FIG. 21 LIMIT THERMOSTAT TERMINALS

P1800

SERVICE (cont.)

OVERFLOW PROTECTION SWITCH

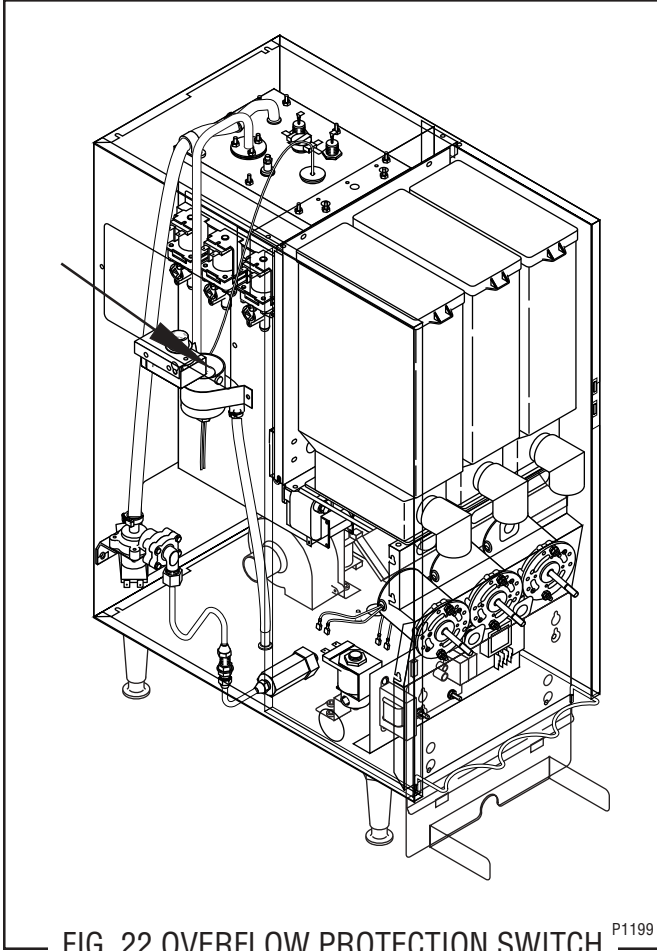

FIG. 22 OVERFLOW PROTECTION SWITCH P1199

Location:

The overflow protection switch is located inside the copper overflow cup on the left side of the tank.

Test Procedures:

1. Disconnect the dispenser from the power source.
2. Remove the wire nuts connecting the red wires from the overflow protection switch to the black wire from the main harness and blue wire from the liquid level board.
3. Check for continuity across the safety overflow switch red wires only until the plastic float is raised and check that continuity returns when the plastic float is again lowered.

If continuity is present as described, reconnect the red wires to the black wire from the main harness and the blue wire from the liquid level board.

If continuity is not present as described, replace the overflow protection switch.

Removal and Replacement:

1. Disconnect the red leads from the overflow protection switch from the black wire from the main harness and the blue wire from the liquid level board.
2. Remove the nut beneath the copper overflow cup.
3. Remove the entire switch assembly from the cup.
4. Place the new switch assembly into the cup, wires first. Make sure that a gasket is in place around the threaded switch stem.

NOTE - The magnets must be at the top of float and there must be NO adjusting washers installed for the overflow protection switch to operate properly.

5. Install the nut beneath the copper overflow cup. Be sure not to overtighten.
6. Refer to Fig. 23 when reconnecting wires.

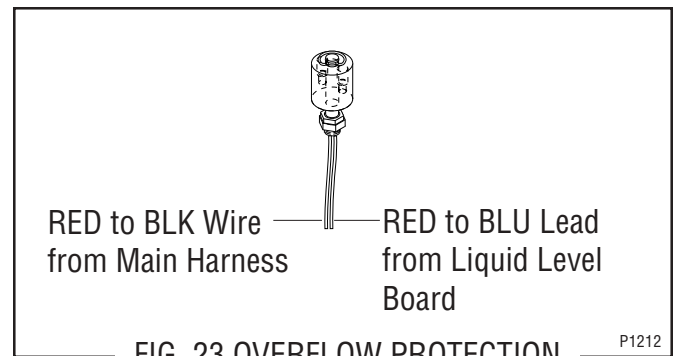
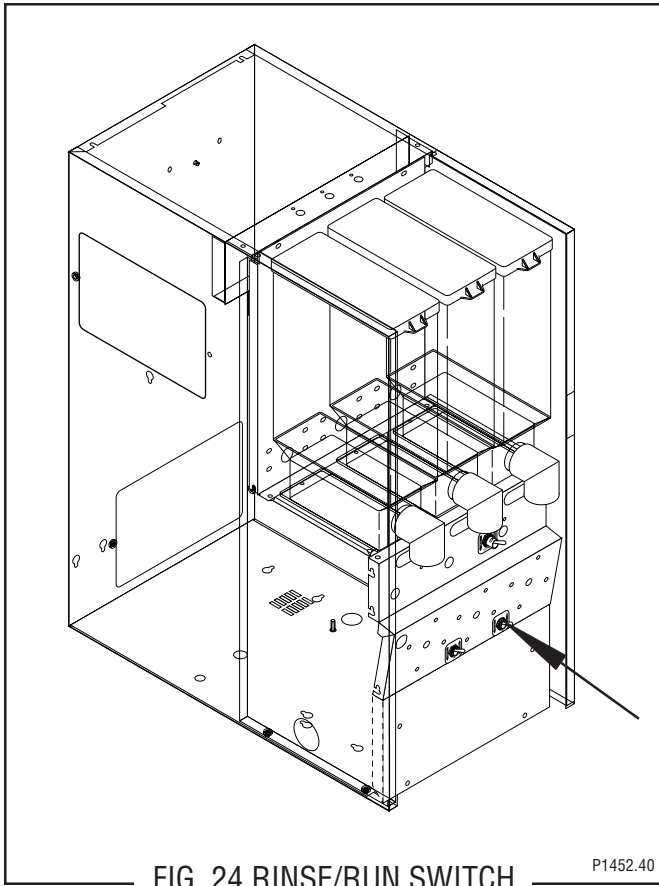

FIG. 23 OVERFLOW PROTECTION SWITCH LEADS P1212

SERVICE (cont.)

RINSE /RUN SWITCH



3. Remove switch with wires attached from the back side of the whipper motor mounting panel.
4. Disconnect the wires from the switch and discard the switch.
5. Refer to Fig. 25 when connecting the wires to the new switch.
6. Install new switch with wires attached through the hole in the whipper motor mounting panel and secure with facenut.

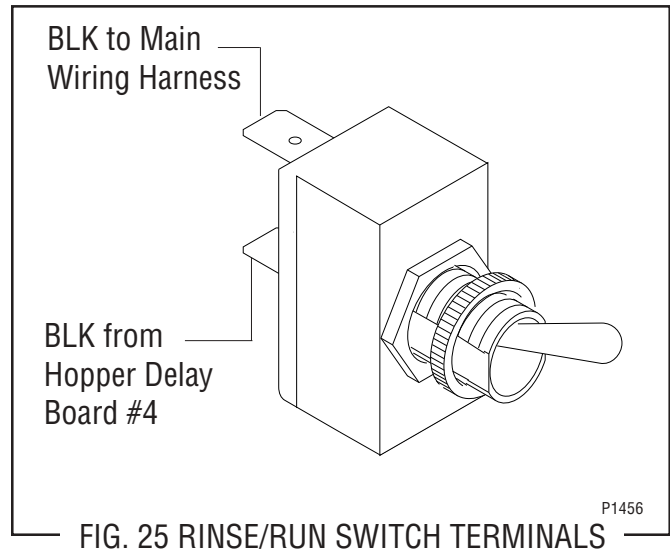

Location:

The rinse/run switch is located on the right side of the whipper motor mounting panel.

Test Procedures:

1. Disconnect the dispenser from the power source.
2. Check for continuity between center terminal and the upper terminal with the switch in the "RUN" lower position. Continuity must not be present with the switch in the "RINSE" upper position.

If continuity is present as described, the switch is operating properly.

If continuity is not present as described, replace the switch.

Removal and Replacement:

1. Open the dispenser door.
2. Remove the facenut securing the run/rinse switch to the whipper motor mounting panel.

SERVICE (cont.)

SOLENOID VALVE (COLD WATER - OPTIONAL)

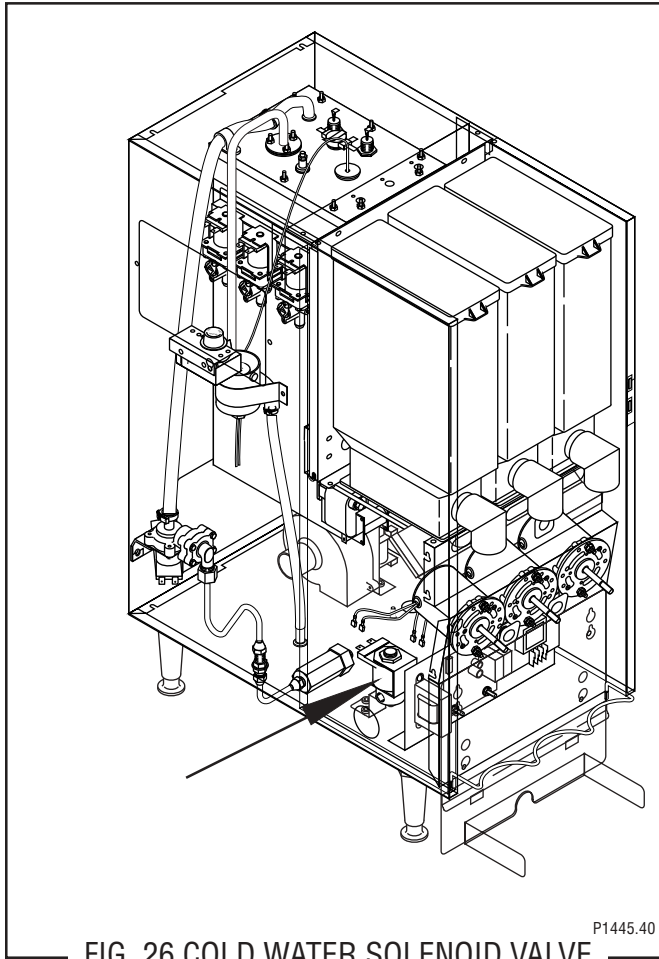

FIG. 26 COLD WATER SOLENOID VALVE

Location:

The cold water solenoid valve is located on the left side of the dispenser base just behind the component bracket.

Test Procedures:

1. Disconnect the dispenser from the power source.
2. Disconnect the white and white/yellow wires from the solenoid valve. With the "HOT/COLD" switch in the "COLD" upper position press the left dispense switch on front of the door.
3. Check the voltage across the white and white/yellow wires with a voltmeter. Connect the dispenser to the power source. The indication must be 120 volts ac for two wire 120 volt models, three wire 120/208, 120/240 volt models and 240 volts ac for two wire 240 volt models.
4. Disconnect the dispenser from the power source.

If voltage is present as described, proceed to #5

If voltage is not present as described, refer to wiring diagram and check dispenser wiring harness.

5. Check for continuity across the solenoid valve coil terminals.

If continuity is present as described, reconnect the white and white/yellow wires to the solenoid.

If continuity is not present as described, replace the solenoid valve.

6. Check the solenoid valve for coil action. Connect the dispenser to the power source. With "HOT/COLD" switch in the "COLD" upper position press the left dispense switch and listen carefully in the vicinity of the solenoid valve for a "clicking" sound as the coil magnet attracts.
7. Disconnect the dispenser from the power source.

If the sound is heard as described and water will not pass through the solenoid valve, there may be a blockage in the water line before the solenoid valve or, the solenoid valve may require inspection for wear, and removal of waterborne particles.

If the sound is not heard as described, replace the solenoid valve.

Removal and Replacement:

1. Loosen the two screws securing the component bracket to the dispenser base. Lift the component bracket off of the base and move to the right.
1. Remove the white and white/yellow wires from the solenoid valve.
2. Turn-off the water supply to the dispenser.
3. Disconnect the water lines to and from the solenoid valve.
4. Loosen the two #8-32 screws and washers securing the solenoid mounting bracket to the base. Remove solenoid bracket and solenoid valve as an assembly.
5. Remove the two #10-32 screws and lockwashers securing the solenoid valve to the solenoid bracket.
6. Using two #10-32 screws and lockwashers install new solenoid valve on solenoid mounting bracket.
7. Install the solenoid valve and bracket on the dispenser base and tighten the two #8-32 screws.

SERVICE (cont.)

SOLENOID VALVE (COLD WATER - OPTIONAL) (cont.)

8. Securely fasten the water lines to and from the solenoid valve.
9. Refer to Fig. 27 when reconnecting the wires.

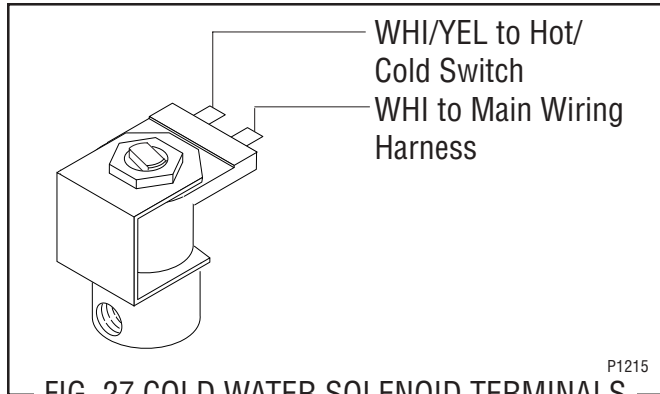

SOLENOID VALVES (DISPENSE)

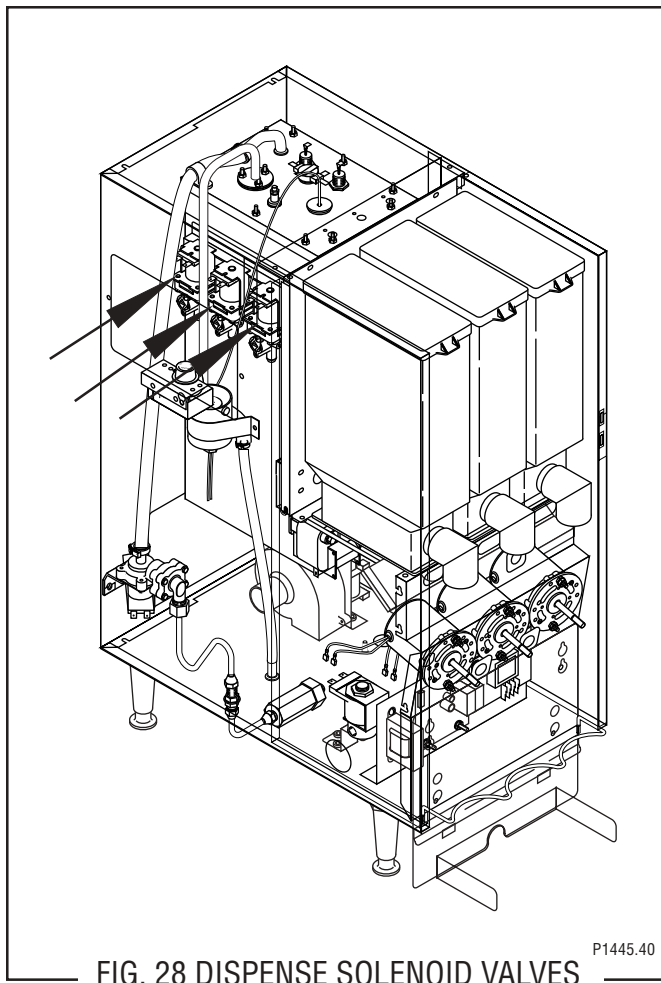

Location:

The dispense solenoids are located on the upper left side of the tank.

Test Procedures:

1. Disconnect the dispenser from the power source.
2. Disconnect the white and white/violet, orange or tan wires from the solenoid valve. With the "RUN/RINSE" switch in the "RINSE" upper position press the appropriate dispense switch on front of the door.
3. Check the voltage across the white and white/violet, orange or tan wires with a voltmeter. Connect the dispenser to the power source. The indication must be 120 volts ac for two wire 120 volt models, three wire 120/208, 120/240 volt models and 240 volts ac for two wire 240 volt models.
4. Disconnect the dispenser from the power source,

If voltage is present as described, proceed to #5

If voltage is not present as described, refer to wiring diagram and check dispenser wiring harness.

5. Check for continuity across the solenoid valve coil terminals.

If continuity is present as described, reconnect the white and white/violet, orange or tan wires to the solenoid.

If continuity is not present as described, replace the solenoid valve.

6. Check the solenoid valve for coil action. Connect the dispenser to the power source. With "RUN/RINSE" switch in the "RINSE" upper position press the appropriate dispense switch and listen carefully in the vicinity of the solenoid valve for a "clicking" sound as the coil magnet attracts.
7. Disconnect the dispenser from the power source.

If the sound is heard as described and water will not pass through the solenoid valve, there may be a blockage in the tank water outlet before the solenoid valve or, the solenoid valve may require inspection for wear, and removal of waterborne particles.

If the sound is not heard as described, replace the solenoid valve.

Removal and Replacement:

1. Remove the white and white/violet, orange or tan wires from the solenoid valve.
2. Turn-off the water supply to the dispenser.

SERVICE (cont.)

SOLENOID VALVES (DISPENSE) (cont.)

3. Drain enough water from the tank (approximately 1.0 gallon) so the water level is below the dispense valve mounting hole.

NOTE: Bunn-O-Matic has a syphon assembly, #12440.0000. available for this purpose.

4. Disconnect the water line from the solenoid valve.
5. Remove the #10-32 screw securing the solenoid valve to side of the tank. Remove solenoid valve.
6. Using the #10-32 screw install new solenoid valve on side of the tank
7. Push the water line onto the tube on bottom of solenoid valve.
8. Refer to Fig. 29 when reconnecting the wires.

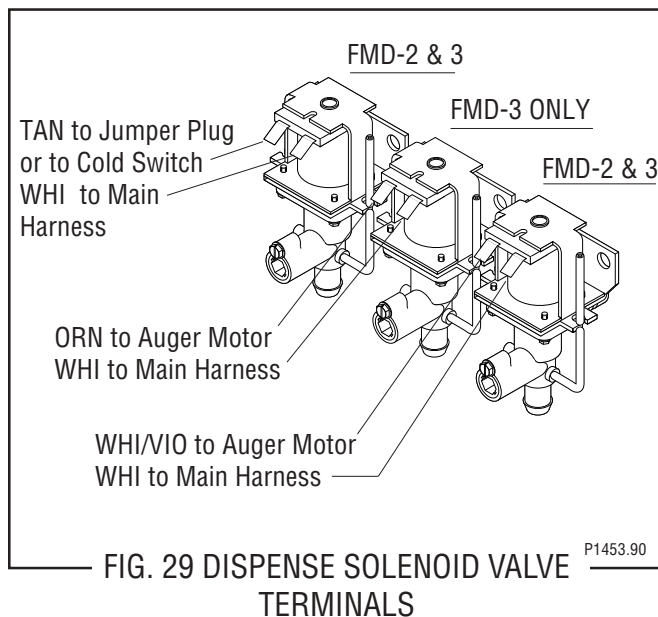

SOLENOID VALVE (INLET)

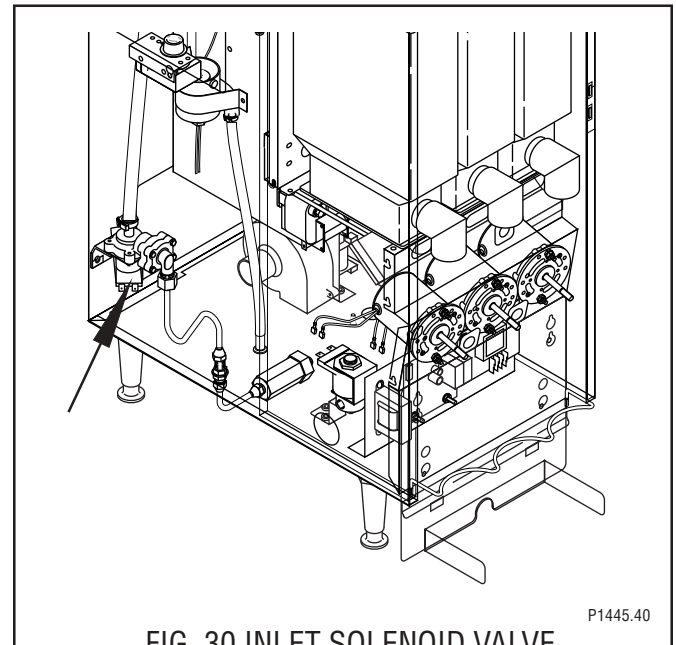

Location:

The inlet solenoid is located inside on the left rear of the dispenser housing.

Test Procedures:

1. Disconnect the dispenser from the power source.
2. Disconnect the white and violet wires from the solenoid valve.
3. Check the voltage across the white and violet wires with a voltmeter. Connect the dispenser to the power source. The indication must be 120 volts ac for two wire 120 volt models, three wire 120/208, 120/240 volt models and 240 volts ac for two wire 240 volt models.
4. Disconnect the dispenser from the power source,

If voltage is present as described, proceed to #5
If voltage is not present as described, refer to the wiring diagram and check dispenser wiring harness.

5. Check for continuity across the solenoid valve coil terminals.

If continuity is present as described, reconnect the white and violet wires to the solenoid.

If continuity is not present as described, replace the solenoid valve.

6. Check the solenoid valve for coil action. Connect the dispenser to the power source. Listen care-

SERVICE (cont.)

SOLENOID VALVE (INLET) (cont.)

fully in the vicinity of the solenoid valve for a "clicking" sound as the coil magnet attracts.

7. Disconnect the dispenser from the power source.

If the sound is heard as described and water will not pass through the solenoid valve, there may be a blockage in the water line before the solenoid valve or, the solenoid valve may require inspection for wear, and removal of waterborne particles.

If the sound is not heard as described, replace the solenoid valve.

Removal and Replacement:

1. Remove the white and violet wires from the solenoid valve.
2. Turn-off the water supply to the dispenser.
3. Disconnect the water lines to and from the solenoid valve.
4. Loosen the two #8-32 screws securing the solenoid to the rear dispenser housing. Remove solenoid.
5. Remove the two #8-32 U-Type fasteners from the solenoid bracket.
6. Install the two #8-32 U-Type fasteners and the two #8-32 screws on the new solenoid.
5. Install new solenoid valve on rear of dispenser housing and tighten the two screws.
6. Securely fasten the water lines to and from the solenoid valve.
7. Refer to Fig. 31 when reconnecting the wires.

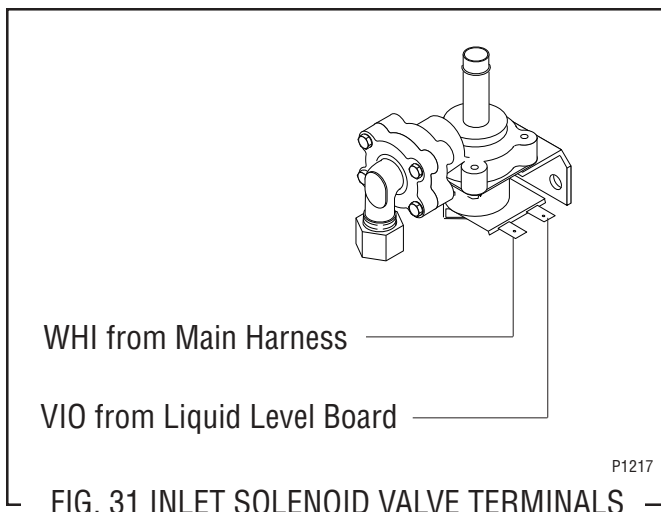

TANK HEATER

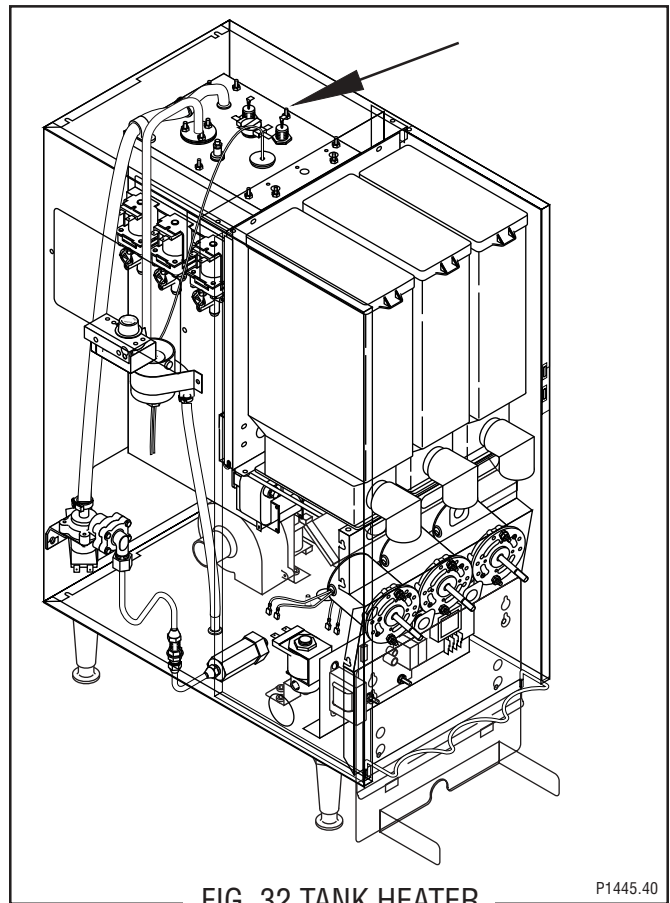

Location:

The tank heater is located inside the tank and secured to the tank lid.

Test Procedure:

1. Disconnect the dispenser from the power source.
2. Check the voltage across the black and white wires 120 volt or 240 volt models or black and red wires for 120/208 volt models or 120/240 volt models with a voltmeter. Connect the dispenser to the power source. The indication must be:
 - a) 120 volts ac for two wire 120 volt models;
 - b) 208 volts ac for three wire 120/208 volt models.
 - c) 240 volts ac for three wire 120/240 volt models and two wire 240 volt models.
3. Disconnect the dispenser from the power source.

If voltage is present as described, proceed to #4. If voltage is not present as described, refer to the dispenser wiring diagram and check the wiring harness.

4. Disconnect the black wire and the white or red wire from the tank heater terminals.

SERVICE (cont.)

TANK HEATER (cont.)

5. Check for continuity across the tank heater terminals.

If continuity is present as described, reconnect the wires, the tank heater is operating properly. If continuity is not present as described, replace the tank heater.

NOTE - If the tank heater remains unable to heat, remove and inspect heater for cracks in the sheath.

Removal and Replacement:

1. Shut-off water supply to the dispenser.
2. Disconnect the water supply tube on the tank lid.
3. Disconnect the black wires on the limit thermostat.
4. Disconnect the black wire and the white or red wire from the tank heater terminals.
5. Disconnect the pink wire from the liquid level probe.
6. Disconnect the green wire from the tank.
7. Remove the thermostat capillary bulb by firmly pulling-up on the capillary at the tank lid. This will disengage the grommet from the tank lid.
8. Remove the ten #8-32 nuts securing the tank lid to the tank.
9. Remove tank lid with limit thermostat, liquid level probe and tank heater as an assembly.
10. Remove the two hex nuts securing the tank heater to the tank lid. Remove tank heater with gaskets and discard.
11. Install new tank heater with gaskets on the tank lid and secure with two hex nuts.
12. Install tank lid with limit thermostat, liquid level probe and tank heater on the tank and secure with ten #8-32 hex nuts.
13. Connect water inlet line to the tank lid.
14. Reconnect the black wires to limit thermostat, the pink wire to the liquid level probe and the green wire to the tank. Refer to the limit thermostat and the liquid level board and probe sections in this manual when reconnecting wires.
15. Refer to Fig. 33 when reconnecting the wires to the tank heater.

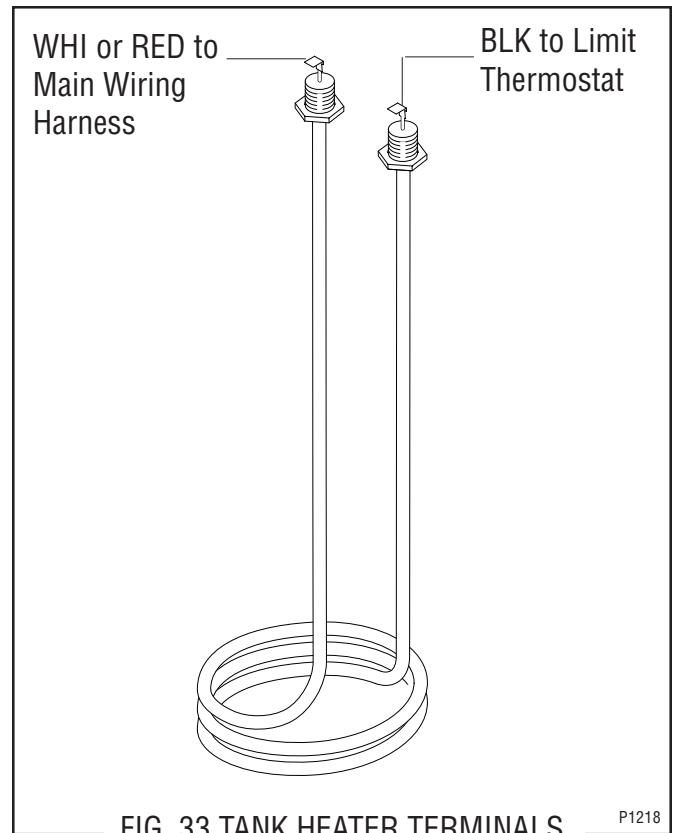

TANK HEATER SWITCH

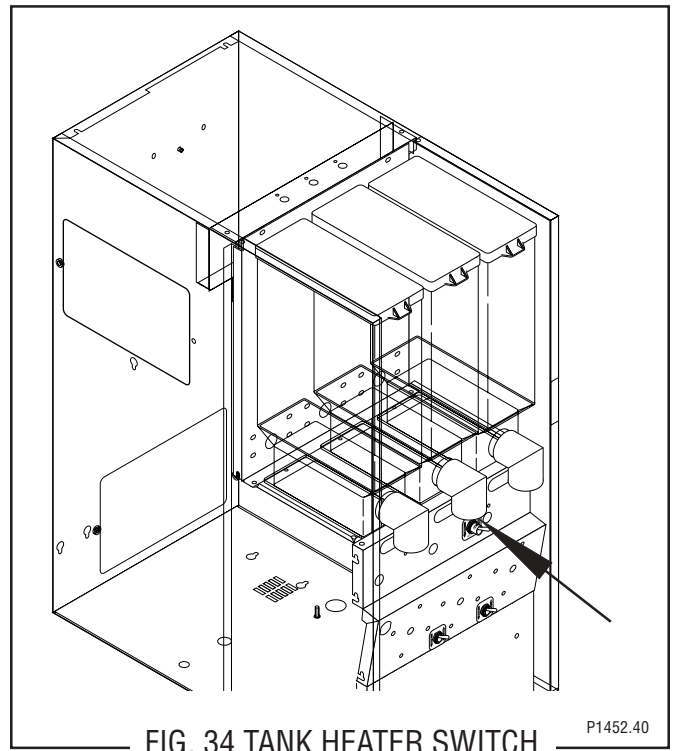

Location:

The tank heater switch located inside the dispenser on the upper right of the whipper motor mounting panel.

SERVICE (cont.)

TANK HEATER SWITCH (cont.)

Test Procedure:

1. Disconnect the dispenser from the power source.
2. Disconnect the black wire from the power supply and the black wire from the control thermostat.
3. With the switch in the “ON” lower position check for continuity between the center and the upper terminal. With the switch in the “OFF” upper position no continuity should be present between center and upper terminals.

If continuity is present as described, the heater “ON/OFF” switch is operating properly.

If continuity is not present as described, replace the switch.

Removal and Replacement:

1. Refer to the hopper section in this manual and remove the hopper assemblies and the hopper support plate.
2. Remove the switch mounting nut on the front of the front panel.
3. Remove switch with wires attached from the rear of the front panel.
4. Remove the wires from the switch terminals and discard switch.
5. Connect the wires to the new switch, refer to fig. 35.
5. Push new switch through hole in the front panel and secure with face nut.
7. Refer to the hopper section in this manual and install the hopper support plate and the hopper assemblies.

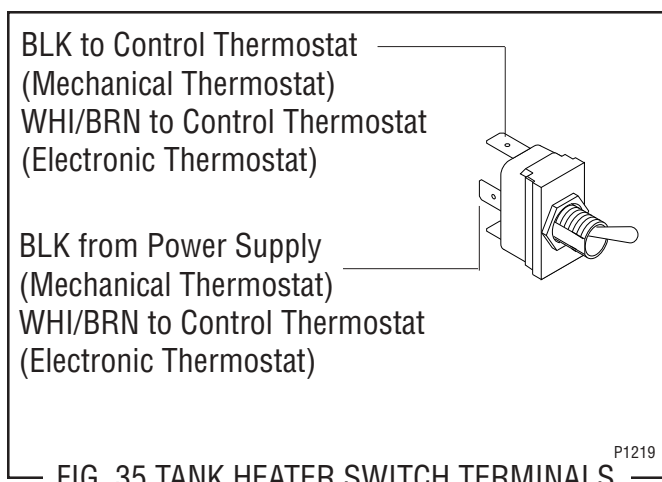
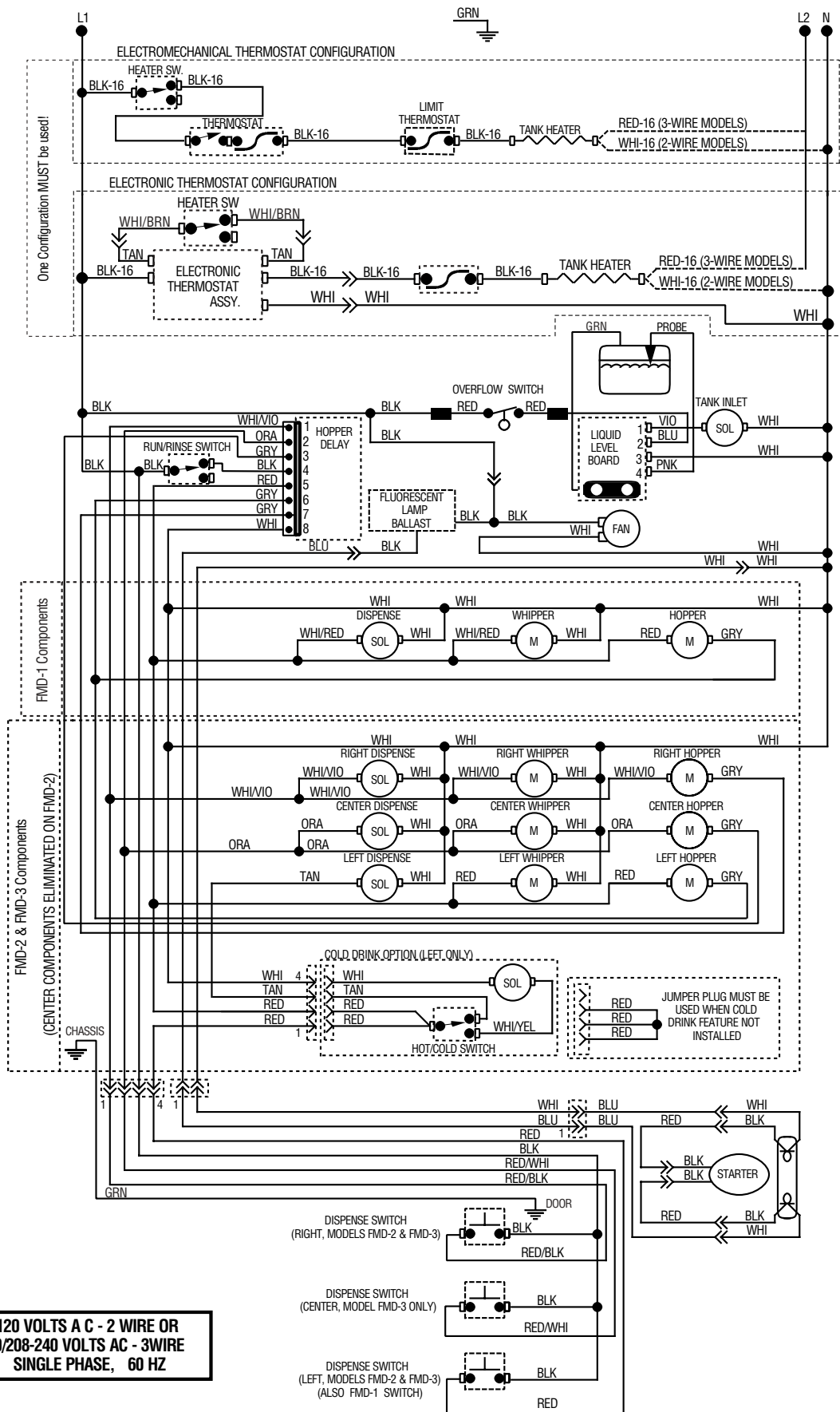

FIG. 35 TANK HEATER SWITCH TERMINALS

SCHEMATIC WIRING DIAGRAM FMD-1, FMD-2, & FMD-3



SCHEMATIC WIRING DIAGRAM FMDA-1, FMDA-2, & FMDA-3

