

BUNN®

OL & RL

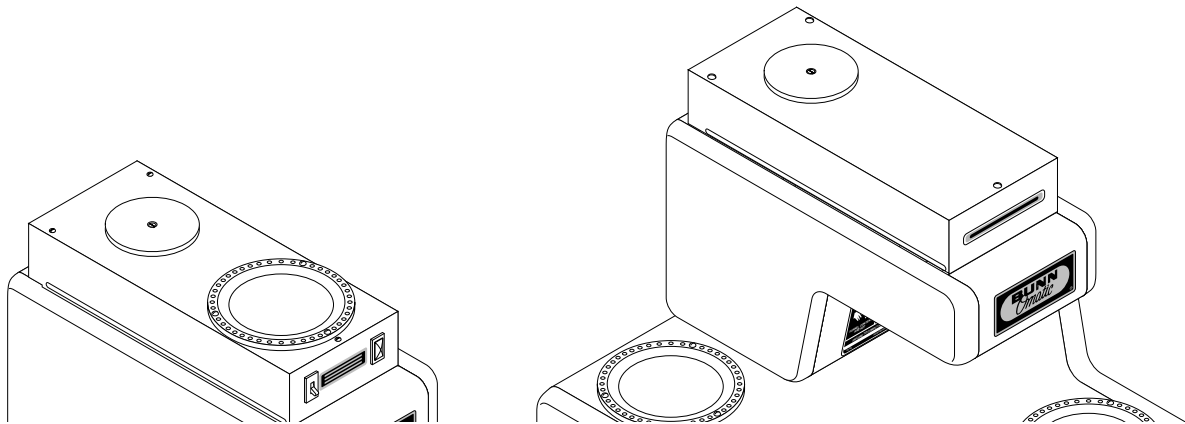

DISCONTINUED VERSION

**The information in this manual
is no longer current.**

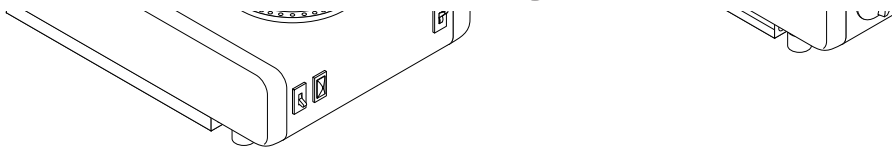

OPERATING & SERVICE MANUAL

BUNN-O-MATIC CORPORATION

POST OFFICE BOX 3227

SPRINGFIELD, ILLINOIS 62708-3227

PHONE: (217) 529-6601 FAX: (217) 529-6644

CONTENTS

Introduction	2
User Notices	3
Electrical Requirements	4
Plumbing Requirements	4
Initial Set-Up	5
Operating Controls	6
Coffee Brewing	7
Cleaning	7
Troubleshooting	8
Service	12
Wiring Diagrams	26

INTRODUCTION

This equipment will brew a half-gallon batch of coffee into an awaiting decanter at the press of a button. The OL has two and the RL has five warmers to keep the beverage at the right temperature, on the RL one of which is capable of heating water to boiling. The brewer is only for indoor use on a sturdy counter or shelf.

WARRANTY

Bunn-O-Matic Corp. ("Bunn") warrants the equipment manufactured by it to be commercially free from defects in material and workmanship existing at the time of manufacture and appearing within one year from the date of installation. In addition:

- 1.) Bunn warrants electronic circuit and/or control boards to be commercially free from defects in material and workmanship for two years from the date of installation.
- 2.) Bunn warrants the compressor on refrigeration equipment to be commercially free from defects in material and workmanship for two years from the date of installation.
- 3.) Bunn warrants that the grinding burrs on coffee grinding equipment will grind coffee to meet original factory screen sieve analysis for three years from date of installation or for 30,000 pounds of coffee, whichever comes first.

This warranty does not apply to any equipment, component or part that was not manufactured by Bunn or that, in Bunn's judgement, has been affected by misuse, neglect, alteration, improper installation or operation, improper maintenance or repair, damage or casualty.

THE FOREGOING WARRANTY IS EXCLUSIVE AND IS IN LIEU OF ANY OTHER WARRANTY, WRITTEN OR ORAL, EXPRESS OR IMPLIED, INCLUDING, BUT NOT LIMITED TO, ANY IMPLIED WARRANTY OF EITHER MERCHANTABILITY OR FITNESS FOR A PARTICULAR PURPOSE. The agents, dealers or employees of Bunn are not authorized to make modifications to this warranty or to make additional warranties that are binding on Bunn. Accordingly, statements by such individuals, whether oral or written, do not constitute warranties and should not be relied upon.

The Buyer shall give Bunn prompt notice of any claim to be made under this warranty by telephone at (217) 529-6601 or by writing to Post Office Box 3227, Springfield, Illinois, 62708-3227. If requested by Bunn, the Buyer shall ship the defective equipment prepaid to an authorized Bunn service location. If Bunn determines, in its sole discretion, that the equipment does not conform to the warranty, Bunn shall repair the equipment with no charge for parts during the warranty period and no charge for labor by a Bunn Authorized Service Representative during the warranty period. If Bunn determines that repair is not feasible, Bunn shall, at its sole option, replace the equipment or refund the purchase price for the equipment.

THE BUYER'S REMEDY AGAINST BUNN FOR THE BREACH OF ANY OBLIGATION ARISING OUT OF THE SALE OF THIS EQUIPMENT, WHETHER DERIVED FROM WARRANTY OR OTHERWISE, SHALL BE LIMITED, AS SPECIFIED HEREIN, TO REPAIR OR, AT BUNN'S SOLE OPTION, REPLACEMENT OR REFUND.

In no event shall Bunn be liable for any other damage or loss, including, but not limited to, lost profits, lost sales, loss of use of equipment, claims of Buyer's customers, cost of capital, cost of down time, cost of substitute equipment, facilities or services, or any other special, incidental or consequential damages.

USER NOTICES

Carefully read and follow all notices on the equipment and in this manual. They were written for your protection. All notices on the equipment should be kept in good condition. Replace any unreadable or damaged labels.

00831.0000

⚠ WARNING
<ul style="list-style-type: none"> ◆ Fill water tank before turning -on thermostat or connecting appliance to power source. ◆ Use only on a properly protected circuit capable of the rated load. ◆ Electrically ground the chassis. ◆ Follow national/local electrical codes. ◆ Do not use near combustibles.
FAILURE TO COMPLY RISKS EQUIPMENT DAMAGE, FIRE, OR SHOCK HAZARD
READ THE ENTIRE OPERATING MANUAL BEFORE BUYING OR USING THIS PRODUCT
THIS APPLIANCE IS HEATED WHENEVER CONNECTED TO A POWER SOURCE
<small>00831.0000F 3/98 © 1988 BUNN-O-MATIC CORPORATION</small>

00658.0000

⚠ WARNING	
 <p>FUNNEL CONTENTS ARE HOT</p>	<p>DISCARD DECANTER IF:</p> <ul style="list-style-type: none"> • CRACKED • SCRATCHED • BOILED DRY • HEATED WHEN EMPTY • USED ON HIGH FLAME OR EXPOSED ELECTRIC ELEMENTS
<p>READ THE ENTIRE OPERATING MANUAL BEFORE USING THIS PRODUCT</p> <p>FAILURE TO COMPLY RISKS INJURY</p>	
<small>PN: 00658.0000F 6/98 © 1985 BUNN-O-MATIC CORPORATION</small>	

This equipment is to be installed to comply with the Basic Plumbing Code of the Building Officials and Code Administrators International, Inc. (BOCA) and the Food Service Sanitation Manual of the Food and Drug Administration (FDA).

00656.0000

⚠ WARNING
<p>HIGH HEAT WARMER</p> <p>DO NOT BOIL DECANTER DRY KEEP COMBUSTIBLES AWAY</p> <p>FAILURE TO COMPLY RISKS GLASS FAILURE/HOT LIQUID BURNS AND FIRE HAZARD</p>

00688.0000

ELECTRICAL REQUIREMENTS

CAUTION - Do not connect the brewer to the power source until specified in Initial Set-Up.

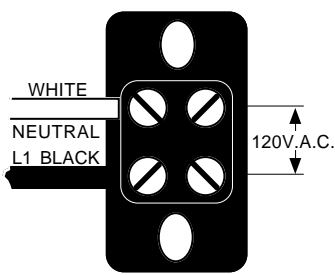

MODELS OL15 & 20 require 2-wire, grounded service rated 120 volts ac, 15 or 20 amp respectively, single phase, 60 Hz.

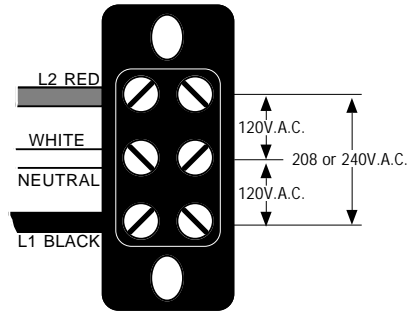

MODELS OL35 & RL35 require 3-wire, grounded service rated 120/208 or 120/240 volts ac, 20 amp, single phase, 60 Hz.

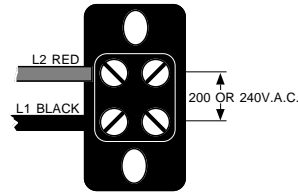

MODELS OLA, RLA, OL35B & RL35B require 2-wire, grounded service rated 240 volts ac or 200 volts ac, 20 amp single phase, 50 Hz.

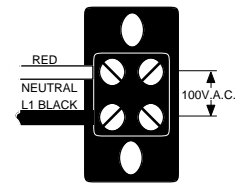

MODEL OL25B & RL25B requires 2-wire, grounded service rated 100 volts ac, 20 amp single phase, 50 Hz.

Electrical Hook-Up

Model OL15 has an attached cordset.

Models OL20, OL35, & RL35, proceed as follows:

CAUTION – Improper electrical installation will damage electronic components.

1. An electrician must provide electrical service as specified.
2. Using a voltmeter, check the voltage and color coding of each conductor at the electrical source.
3. Remove the top panel and rotate the control thermostat knob fully counterclockwise to the "OFF" position and replace the panel.
4. Remove the rear panel, feed the cord through the strain relief, and connect it to the terminal block.
5. Connect the brewer to the power source and verify the voltage at the terminal block before proceeding. Replace the rear panel.
6. If plumbing is to be hooked-up later be sure the brewer is disconnected from the power source. If Plumbing has been hooked-up, the brewer is ready for Initial Set-Up.

PLUMBING REQUIREMENTS

This brewer must be connected to a **cold** water system with operating pressure between 20 and 90 psi from a 1/2" or larger supply line. A shut-off valve should be installed in the line before the brewer. Install a regulator in the line when pressure is greater than 90 psi to reduce it to 50 psi. The water inlet fitting is 1/4" flare.

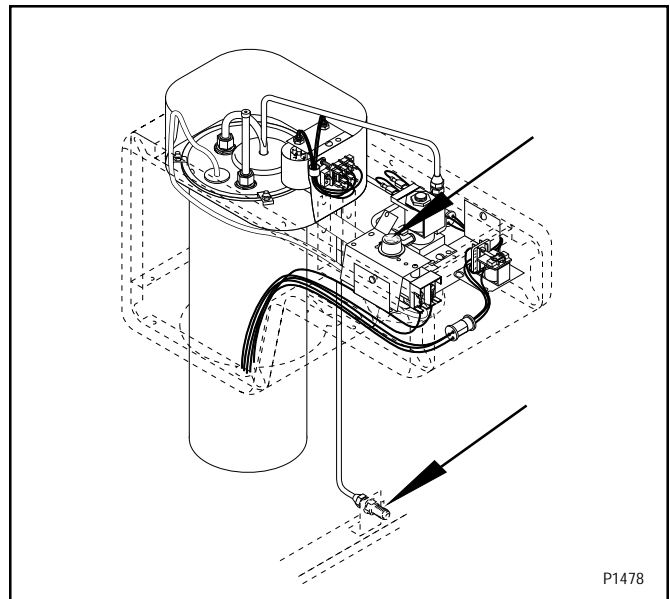

NOTE - Bunn-O-Matic recommends 1/4" copper tubing for installations of less than 25 feet and 3/8" for more than 25 feet from the 1/2" water supply line. A tight coil of copper tubing in the water line will facilitate moving the brewer to clean the counter top. Bunn-O-Matic does not recommend the use of a saddle valve to install the brewer. The size and shape of the hole made in the supply line by this type of device may restrict water flow.

This equipment must be installed to comply with the Basic Plumbing Code of the Building Officials and Code Administrators International, Inc. (BOCA) and the Food Service Sanitation Manual of the Food and Drug Administration (FDA).

PLUMBING REQUIREMENTS (Cont.)

Plumbing Hook-Up

Model OL15 has an attached water strainer, proceed to step 2.

Models OL20, OL35, & RL35, proceed as follows:

1. Remove the rear panel and bottom pan. Run the long piece of tubing from the strainer (supplied) under the brewer and attach it to the water inlet fitting on the bottom bracket. Reinstall the bottom pan and rear panel.
2. Flush the water line and securely attach it to the 1/4" flare fitting on the strainer.
3. Turn on the water supply.

INITIAL SETUP

CAUTION - The brewer must be disconnected from the power source throughout the initial setup, except when specified in the instructions.

1. Remove the top panel.
2. Rotate the control thermostat knob fully counterclockwise to the "OFF" position and replace the panel.
3. Insert an empty funnel into the funnel rails.
4. Place a decanter containing a small amount of water on the warmer beneath the funnel.
5. Connect the brewer to the power source, place the On/Off brew station warmer switch the upper position, and momentarily press the start switch. Water will begin flowing into the tank. When water stops flowing into the tank, initiate a second and a third brew cycle. During this third brew cycle the tank will fill to its capacity and the excess will flow from the sprayhead, out of the funnel, and into the decanter.
6. Place the On/Off brew station warmer switch in the lower position.
7. Disconnect the brewer from the power source.
8. Remove the top panel.
9. Rotate the control thermostat knob fully clockwise to the "ON" position and replace the panel.
10. Connect the brewer to the power source and wait approximately twenty minutes for the water in the tank to heat to the proper temperature. Some water will drip from the funnel during this time; this is due to expansion and should not occur thereafter.
11. Place an empty decanter under the funnel.
12. Place the On/Off brew station warmer switch in the upper position and momentarily press the start switch. Empty the decanter after water has stopped flowing from the funnel.
13. Allow the water in the tank to reheat to the proper temperature.
14. Place an empty decanter on the warmer and press the start switch. Check the water volume in the decanter after water has stopped flowing from the funnel. It should be 64 ounces.
15. If not, disconnect the brewer from the power source and remove the top panel.
16. Add or remove washers to the float on the level switch as required. Adding washers increases the volume, removing washers decreases it. Replace the top panel, connect the brewer to the power source, start, and measure another brew cycle.
17. Repeat steps 13-16 until 64 oz water volume is achieved.

NOTE - The On/Off brew station warmer switch must be in the upper position to initiate and complete a brew cycle.

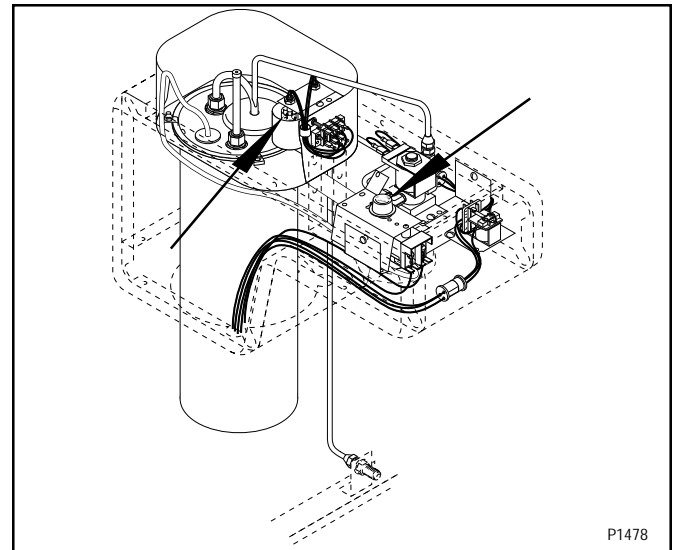
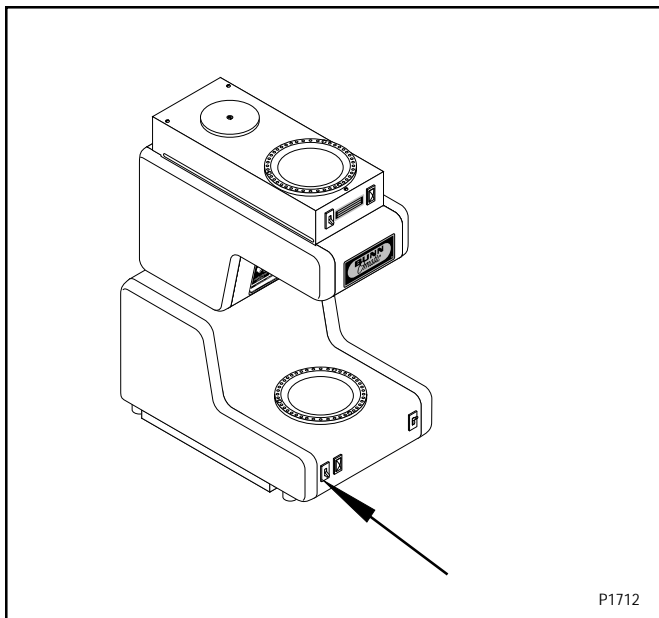

OPERATING CONTROLS

A. On/Off Brew Station Warmer Switch

Placing the switch in the upper position supplies power to the brew station warmer and enables brewing. Placing the switch in the lower position cuts power to the brew station warmer and stops brewing. Stopping a brew cycle after it has been started will not stop the flow of water into the funnel until the tank syphons down to its proper level.

NOTE - The On/Off brew station warmer switch must be in the upper position to initiate and complete a brew cycle.

B. On/Off Brew Station Warmer Indicator Lamp

Glowes whenever the On/Off brew station warmer switch is in the upper position showing that the warmer is on and that the automatic brew cycle can be started.

C. Start Switch

Starts a brew cycle when the On/Off brew station warmer switch is in the upper position.

MODEL OL

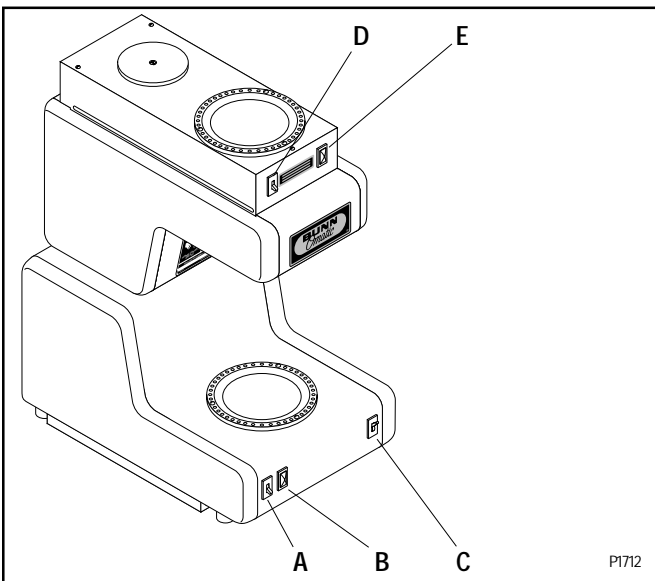

D. Upper Warmer Switch

Placing the switch in the upper position supplies power to the upper warmer. Placing the switch in the lower position cuts power to the upper warmer.

E. Upper Warmer Indicator Lamp

Glowes whenever the upper warmer switch is in the upper position showing that the warmer is on.

F. Left Rear Warmer Rotary Switch

Rotating the knob to the "ON" position supplies power to the left rear warmer. Rotating the knob to the "OFF" position cuts power to the left rear warmer.

G. Left Front Warmer Rotary Switch

Rotating the knob to the "ON" position supplies power to the left front warmer. Rotating the knob to the "OFF" position cuts power to the left front warmer.

H. Right Front Warmer Rotary Switch

Rotating the knob to the "ON" position supplies power to the right front warmer. Rotating the knob to the "OFF" position cuts power to the right front warmer.

I. Right Rear Warmer Three Heat Rotary Switch

Rotating the knob to the "LO", "MED", or "HIGH" positions supply power to the right rear warmer. Rotating the knob to the "OFF" position cuts power to the right rear warmer. The "HIGH" position of this switch makes the warmer capable of boiling water.

MODEL RL

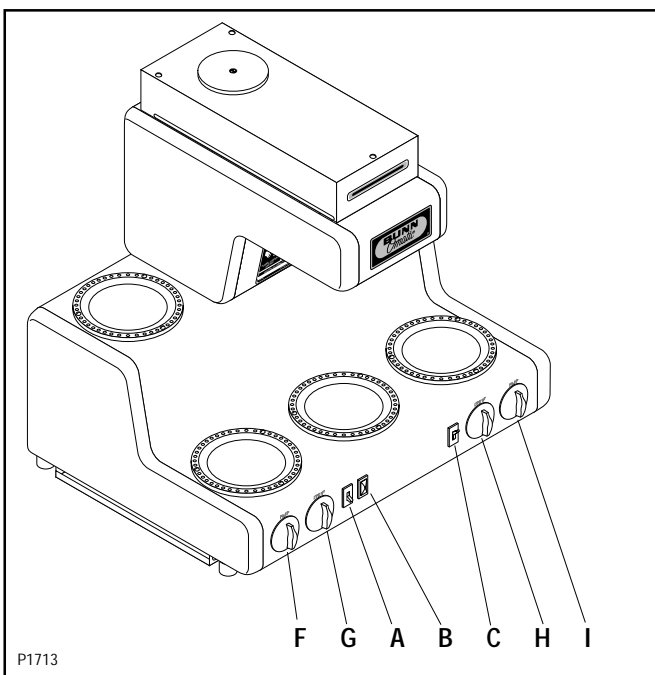

COFFEE BREWING

Start each brew cycle with an empty, clean, half-gallon decanter.

1. Insert a BUNN® filter into the funnel.
2. Pour the fresh coffee into the filter and level the bed of grounds by gently shaking.
3. Slide the funnel into the funnel rails.
4. Place the On/Off brew station warmer switch in the upper position.
5. Momentarily press the start switch.
6. When brewing is completed, simply discard the grounds and filter.

CLEANING

1. The use of a damp cloth rinsed in any mild, non-abrasive, liquid detergent is recommended for cleaning all surfaces on Bunn-O-Matic equipment.
2. Check and clean the sprayhead. The sprayhead holes must always remain open.
3. With the sprayhead removed, insert the deliming spring (provided) all the way into the sprayhead tube. When inserted properly, no more than two inches of spring should be visible. Saw back and forth five or six times.

NOTE - In hard water areas, this may need to be done daily. It will help prevent liming problems in the brewer and takes less than a minute.

TROUBLESHOOTING

A troubleshooting guide is provided to suggest probable causes and remedies for the most likely problems encountered. If the problem remains after exhausting the troubleshooting steps, contact the Bunn-O-Matic Technical Service Department.

- Inspection, testing, and repair of electrical equipment should be performed only by qualified service personnel.
- All electric components have 120 volt ac voltage on their terminals. Shorting of terminals or the application of external voltages may result in equipment failure.
- Intermittent operation of electronic equipment is unlikely. Component failure will normally be permanent. If an intermittent condition is encountered, the cause will likely be a switch contact or a loose connection at a terminal or crimp.
- Solenoid removal requires interrupting the water supply to the valve. Damage may result if solenoids are energized for more than ten minutes without a supply of water.
- The use of two wrenches is recommended whenever plumbing fittings are tightened or loosened. This will help to avoid twists and kinks in the tubing.
- Make certain that all plumbing connections are sealed and electrical connections tight and isolated.
- This brewer is heated at all times unless disconnected from the power source. Keep away from combustibles.

WARNING

- Exercise extreme caution when servicing electrical equipment.
- Disconnect the brewer from the power source when servicing, except when electrical tests are specified.
- Follow recommended service procedures
- Replace all protective shields or safety notices

Problem	Probable Cause	Remedy
Equipment will not operate.	1. No power or incorrect voltage	(A) Connect the brewer to the power source. (B) Check the terminal block for the proper voltages. (C) Check circuit breaker/fuse.
	2. Water Strainer	(A) Direction of flow arrow must be pointing towards brewer. (B) Remove the strainer and check for obstructions. Clear or replace.
	3. Water Level Switch and Overflow Safety Switch	Refer to Service - Water Level Switch and Overflow Safety Switch for testing procedures. See page 25.
Brew cycle will not start.	1. No water	Check plumbing and shut-off valves.

TROUBLESHOOTING (cont.)

Problem	Probable Cause	Remedy
Brew cycle will not start. (cont.)	4. On/Off Brew Station Warmer Switch	Refer to Service - On/Off Brew Station Warmer Switch for testing procedures. See page 16.
	5. Start Switch	Refer to Service - Start Switch for testing procedures. See page 19.
	6. Relay	Refer to Service - Relay for testing procedures. See page 23.
	7. Solenoid Valve	Refer to Service - Solenoid Valve for testing procedures. See page 22.
Water flows into fill basin continuously (On/Off brew station warmer switch "OFF").	1. Solenoid Valve	Refer to Service - Solenoid Valve for testing procedures. See page 22.
Water flows into fill basin continuously (On/Off brew station warmer switch "ON").	1. Start Switch	Refer to Service - Start Switch for testing procedures. See page 19.
Water is not hot.	1. Limit Thermostat	Refer to Service - Limit Thermostat for testing procedures. See page 21.
	CAUTION Do not eliminate or bypass limit thermostat. Use only B.O.M. replacement part #29329.1000	
	2. Control Thermostat	Refer to Service - Control Thermostat for testing procedures. See page 13.
	3. Tank Heater	Refer to Service - Tank Heater for testing procedures. See page 24.
Decanter warmer is not hot.	1. Warmer Switches	(A) The Warmer Switch(es) must be in the "ON" position for the warmer to operate. (B) Refer to Service - Warmer Switch(es) for testing procedures. See pages 16,17, & 18.
	2. Decanter Warmers	Refer to Service - Warmers for testing procedures. See pages 14 & 15.

TROUBLESHOOTING (cont.)

Problem	Probable Cause	Remedy
Spitting or unusual steaming from sprayhead.	1. Control Thermostat	Refer to Service - Control Thermostat for testing procedures. See page 13.
	2. Lime build-up CAUTION Tank and tank components should be delimed regularly depending on local water conditions. Excessive mineral build-up on stainless steel surfaces can initiate corrosive reactions resulting in serious leaks.	Inspect the tank assembly for excessive lime deposits. Delime as required.
Warmer plates too hot, solenoid coil smoking, or water in tank heats excessively fast.	1. Brewer wired to wrong voltage	Refer to Electrical Requirements - Page 4.
Inconsistent beverage level in decanter.	1. Improper water pressure	Check the operating water pressure to the brewer. It must be between 20 and 90 psi.
	2. Syphon system	Water should flow freely from the sprayhead and then stop abruptly. The brewer must be level from front-to-back to syphon properly.
Dripping from sprayhead.	1. Syphon system	Water should flow freely from the sprayhead and then stop abruptly. The brewer must be level from front-to-back to syphon properly.
	2. Solenoid Valve	Refer to Service - Solenoid Valve for testing procedures. See page 22.

TROUBLESHOOTING (cont.)

Problem	Probable Cause	Remedy
Beverage overflows decanter.	1. Beverage left in decanter	The brew cycle should be started only with an empty decanter under the funnel.
Weak beverage.	1. Type of paper filters	BUNN® paper filters should be used for proper extraction.
	2. Coffee	A sufficient quantity of fine or drip grind coffee should be used for proper extraction.
	3. Sprayhead	B.O.M. sprayhead #01082.0000 should be used to properly wet the bed of ground coffee in the funnel.
	4. Funnel loading	The BUNN® paper filter should be centered in the funnel and the bed of coffee leveled by gentle shaking.
	5. Water temperature	Place a funnel over an empty decanter on the warmer beneath the sprayhead. Place the On/Off brew station warmer switch in the upper position, press the start switch, and check the water temperature immediately below the sprayhead with an accurate thermometer. The reading should not be less than 195° F. Adjust the control thermostat slightly clockwise to increase the water temperature.
Brewer is making unusual noises.	1. Solenoid Valve	The nut on top of the solenoid valve must be tight or it will vibrate during operation.
	2. Plumbing lines	Plumbing lines should not rest on the counter top.
	3. Water supply	(A) The brewer must be connected to a cold water line. (B) Water pressure to the brewer must not be higher than 90 psi. Install a regulator if necessary to lower the working pressure to approximately 50 psi.

SERVICE

This section provides procedures for testing and replacing various major components used in this brewer should service become necessary. Refer to Troubleshooting for assistance in determining the cause of any problem.

Component Access

WARNING - Disconnect the brewer from the power source before the removal of any panel or the replacement of any component.

The control thermostat, solenoid valve and relay are located under the top cover or top warmer housing, FIG. 1, attached with three #8-32 slotted-head screws.

The base warmer(s), switch(es), indicator lamp, start switch, tank "keep warm" heater and terminal block are located in the base. Access is gained by removing the rear panel, FIG. 1 attached with two #8-32 slotted-head screws

The limit thermostat and tank heater are located on the tank assembly. Access is gained by removing the rear panel, FIG. 1 attached with two #8-32 slotted head screws.

On the model OL, the upper warmer, switch, and associated indicator lamp are located on the removable top warmer housing, FIG. 1.

WARNING - Inspection, testing, and repair of electrical equipment should be performed only by qualified service personnel. The brewer should be disconnected from the power source when servicing, except when electrical tests are required and the test procedure specifically states to connect the brewer to the power source.

Contents

Control Thermostat	13
Warmer(s)	
OL: Brew Station & Upper	14
RL: Left Rear, Left Front, Brew Station, & Right Front ..	14
RL: Right Rear Three Heat	15
Warmer Switch(es)	
OL: On/Off Brew Station & Upper	16
RL: On/Off Brew Station	16
RL: Left Rear, Left Front, & Right Front Rotary	17
RL: Right Rear Three Heat Rotary	18
Start Switch	19
Indicator Lamp(s)	20
Limit Thermostat	21
Solenoid Valve	22
Relay	23
Tank Heater	24
Over Flow Safety Switch	25
Wiring Schematics	26

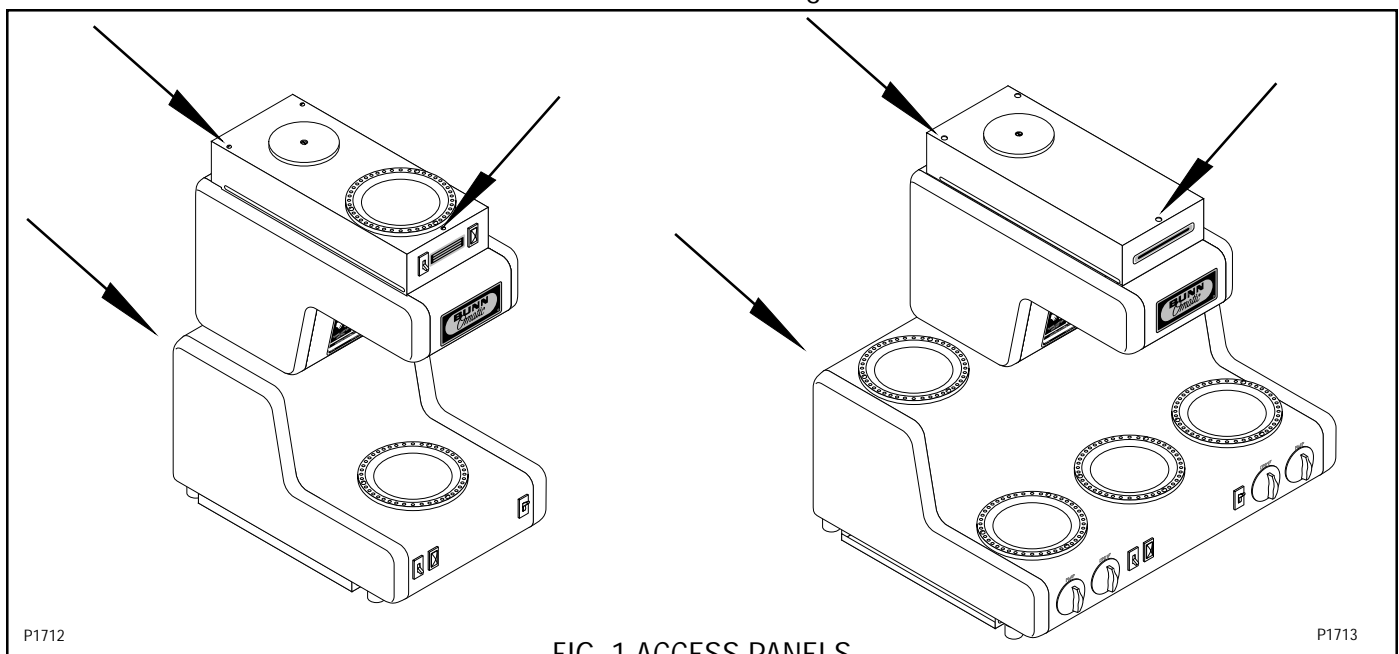

FIG. 1 ACCESS PANELS

SERVICE (cont.)

Control Thermostat

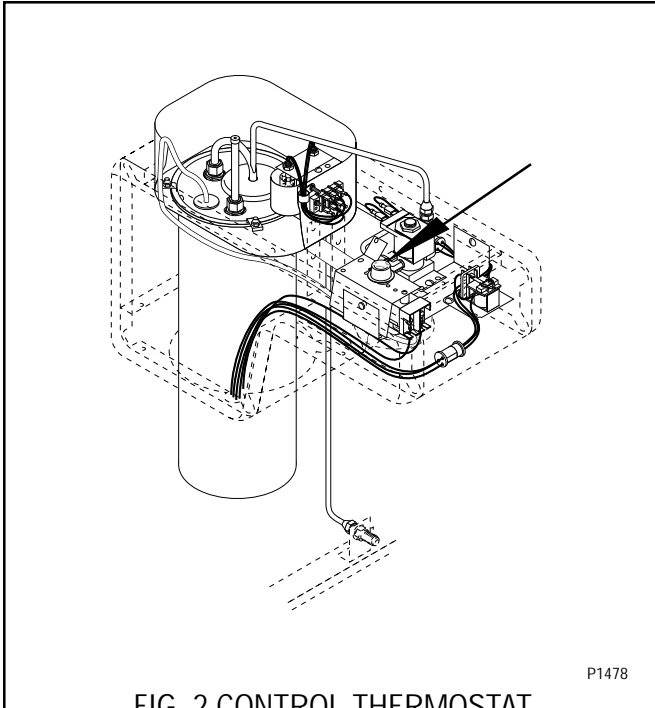

FIG. 2 CONTROL THERMOSTAT

Location:

The control thermostat is located under the top cover or top warmer housing, FIG. 2.

To test the control thermostat, access will also be needed to the tank heater located in the bottom of the tank assembly.

Test Procedure:

1. Disconnect the brewer from the power source.
2. Check the voltage across the blue wire on the control thermostat and the white or red wire on the tank heater with a voltmeter. Connect the brewer to the power source. The indication must be:
 - a) 120 volts ac for two wire 120 volt models.
 - b) 200 or 240 volts ac for two wire 200 volt or 240 volt models and three wire 120/240 volt models.
 - c) 100 volts ac for two wire 100 volt models.
3. Disconnect the brewer from the power source.

If voltage is present as described, proceed to #4.
If voltage is not present as described, refer to the Wiring Diagrams and check the brewer wiring harness.

4. Check the voltage across the black wire terminal of the control thermostat and the white or red wire on the tank heater with a voltmeter when the control thermostat is turned "ON" (fully clockwise). Connect the brewer to the power source.

The indication must be as described in step 2. Voltage must not be indicated across these terminals when the thermostat is turned "OFF" (fully counterclockwise).

5. Disconnect the brewer from the power source.

If voltage is present as described, the control thermostat is operating properly.

If voltage is not present as described, replace the control thermostat.

Removal and Replacement:

1. Remove the top cover or top warmer housing from the brewer to gain access.
2. Remove both wires from the control thermostat terminals.
3. Remove the thermostat bulb by firmly pulling-up on the capillary tube at the tank lid. This will disengage the grommet from the tank lid.
4. Remove the two #8-32 screws holding the control thermostat to the bracket.
5. Fasten the new control thermostat to the component bracket.

NOTE - Make sure that the capillary tube is away from any electrical termination and is not kinked.

6. Slide the grommet to the red mark on the capillary tube.
7. Insert the bulb through the hole in the tank lid and press the grommet firmly and evenly so that the groove in the grommet fits into the tank lid.
8. Carefully bend the capillary tube so that the tube and bulb inside the tank are in a vertical position.
9. Refer to FIG. 3 when reconnecting the wires.
10. Readjust the control thermostat dial as required.

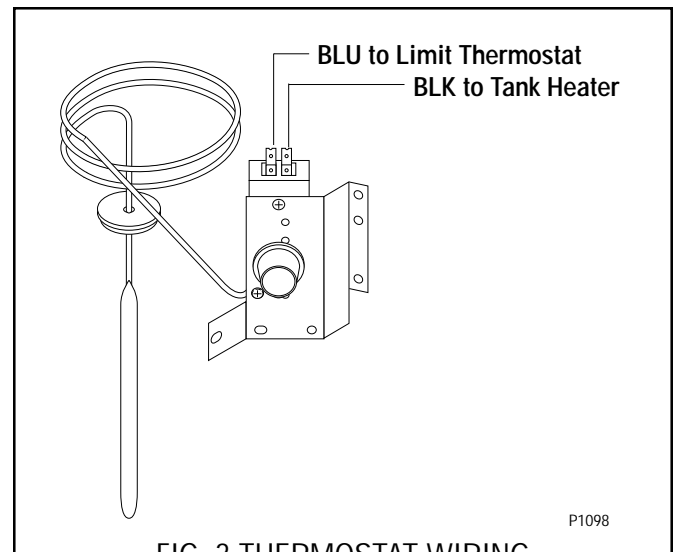

FIG. 3 THERMOSTAT WIRING

SERVICE (cont.)

Warmer(s)

OL: Brew Station & Upper

RL: Left Rear, Left Front, Brew Station, & Right Front

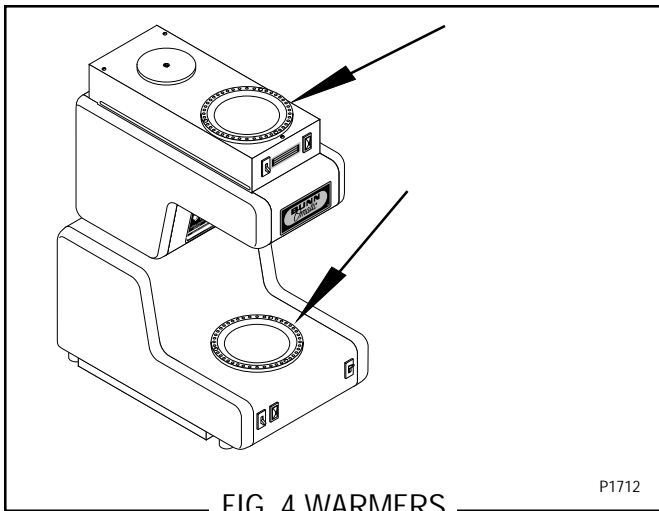

FIG. 4 WARMERS

P1712

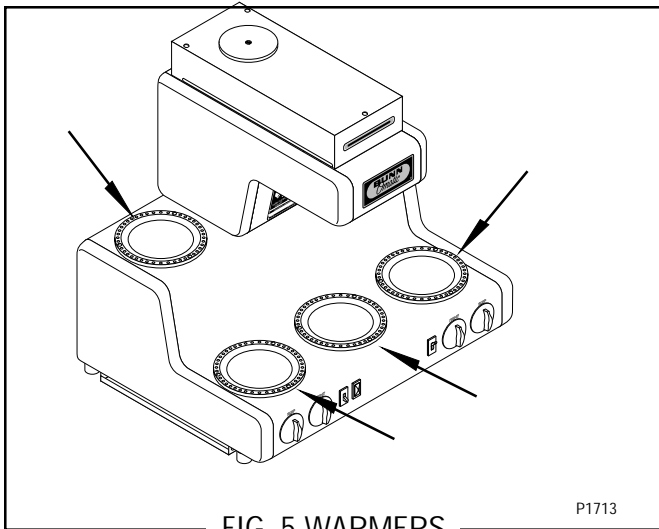

FIG. 5 WARMERS

P1713

Location:

OL: One of the warmers is beneath the brew funnel and the other is on the top lid, FIG. 4.

RL: These warmers include the one beneath the brew funnel, the ones on the right and left of the brew station, and the one above and to the left of the brew station as viewed from the front, FIG. 5.

Test Procedure:

1. Once the switch has been tested and switch failure has been eliminated, proceed as follows.
2. Disconnect the brewer from the power source and remove the #4-40 screws attaching the warmer being tested.
3. Lift the warmer assembly from the brewer and invert the warmer making the wire terminals accessible for testing.
4. Check for continuity from the switch to the black wire at the warmer element.

If continuity is present as described, proceed to #5.

5. Check for continuity from the wire terminal of the white or red wire to the splice or indicator lamp using the chart below.

If continuity is present as described, proceed to #6. If continuity is not present as described, refer to the Wiring Diagrams and check the brewer wiring harness.

6. Check for continuity across the two terminals on the warmer.

If continuity is present as described, the warmer is operating properly.

If continuity is not present as described, replace the warmer.

Removal and Replacement:

1. Remove the #4-40 slotted-head screws holding the warmer to the brewer
2. Lift the warmer assembly from the brewer.
3. Disconnect both wires from the warmer.
4. Refer to FIG. 6 when reconnecting the wires.
5. Place the new warmer into the brewer and securely attach it using the #4-40 screws.

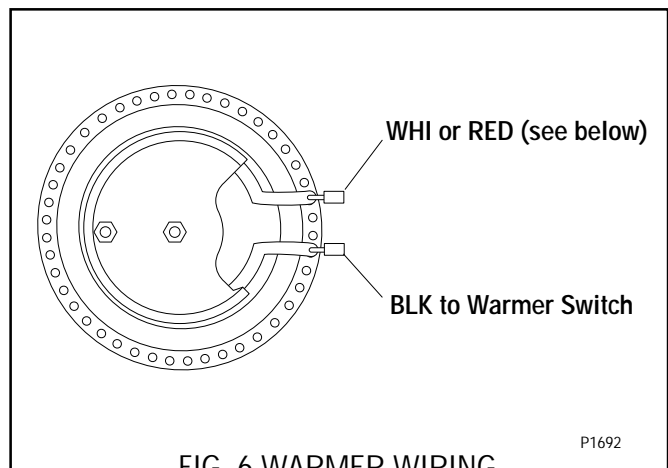

FIG. 6 WARMER WIRING

P1692

MODEL

OL Upper	WHI OR RED	to Indicator Lamp
OL Brew Station	WHI OR RED	to Indicator Lamp to Terminal Block
RL Left Rear	WHI OR RED	to Terminal Block to Brew Station Warmer
RL Left Front	WHI OR RED	to Indicator Lamp
RL Brew Station	WHI OR RED	to Relay P2 to Left Rear Warmer
RL Right Front	WHI OR RED	to Right Rear Warmer Switch

SERVICE (cont.)

Warmer

RL: Right Rear Three Heat

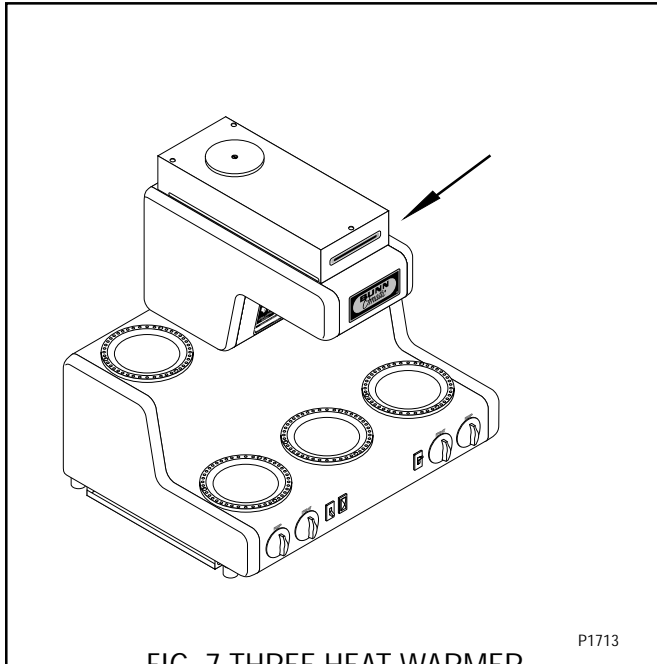

FIG. 7 THREE HEAT WARMER

Location:

The three heat warmer is above and to the right of the brew station as viewed from the front, FIG. 7.

Test Procedure:

1. Once the switch has been tested and switch failure has been eliminated, proceed as follows.
2. Disconnect the brewer from the power source and remove the #4-40 screws attaching the warmer being tested.
3. Lift the warmer assembly from the brewer and invert the warmer making the wire terminals accessible for testing.
4. Check for continuity of the red wire, the white wire, then the brown wire from the switch to the warmer element.

If continuity is present as described, proceed to #5. If continuity is not present as described, refer to the Wiring Diagrams and check the brewer wiring harness.

5. Check for continuity across the two outside terminals on the warmer. Then across one of the outside terminals and the center terminal. Finally, across the other outside terminal, and the center terminal.

If continuity is present as described, the warmer is operating properly. If continuity is not present as described, replace the warmer.

Removal and Replacement:

1. Remove the #4-40 slotted-head screws holding the warmer to the brewer
2. Lift the warmer assembly from the brewer.
3. Disconnect the wires from the warmer.
4. Refer to FIG. 8 when reconnecting the wires.
5. Place the new warmer into the brewer and securely attach it using the #4-40 screws.

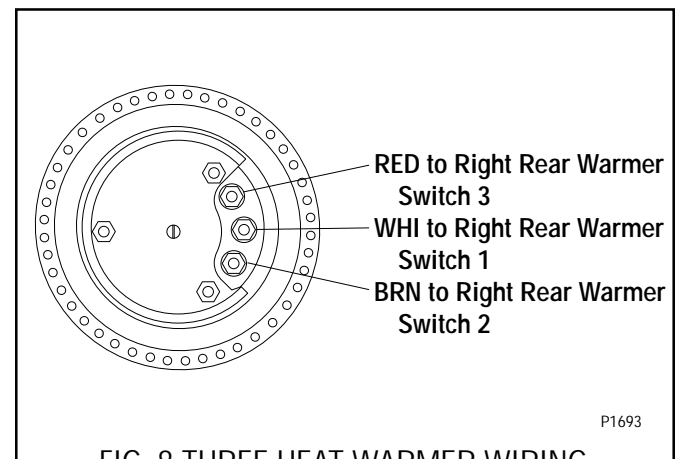

FIG. 8 THREE HEAT WARMER WIRING

SERVICE (cont.)

Warmer Switch(es)

OL: On/Off Brew Station & Upper

RL: On/Off Brew Station

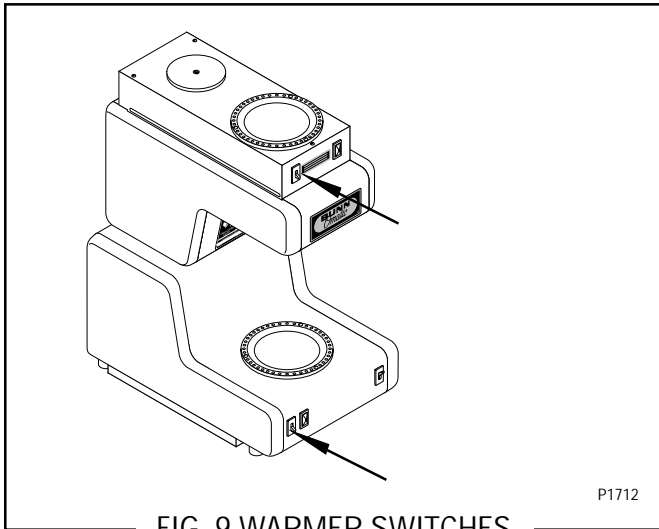

FIG. 9 WARMER SWITCHES

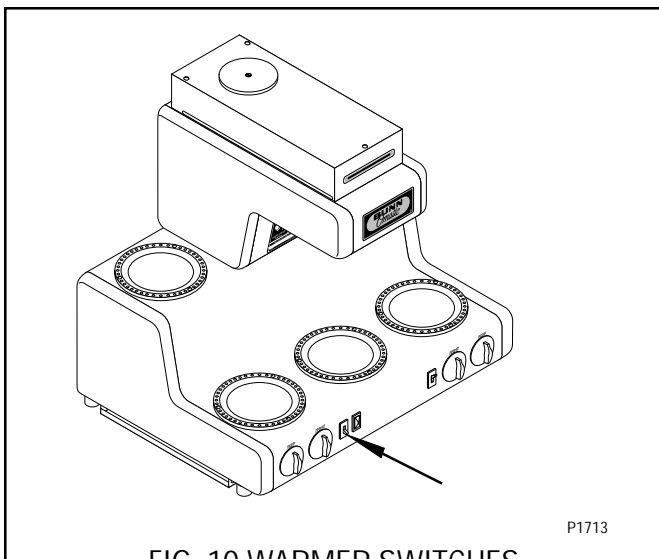

FIG. 10 WARMER SWITCHES

Location:

These switches are located beneath and to the left of their associated warmers as viewed from the front, FIG.s 9 and 10.

Test Procedure:

1. Locate the switch terminal with black wires that do not go to the nearby indicator lamp.
2. Check the voltage across this terminal and the terminal on the indicator lamp with white or red wires with a voltmeter. Connect the brewer to the power source. The indication must be:
 - a) 120 volts ac for two wire 120 volt models and three wire 120/240 volt models.
 - b) 200 or 240 volts ac for two wire 200 volt or 240 volt models.
 - c) 100 volts ac for two wire 100 volt models.
3. Disconnect the brewer from the power source.

If voltage is present as described, proceed to #4. If voltage is not present as described, refer to the Wiring Diagrams and check the brewer wiring harness.

4. Check the voltage across the other switch terminal and the terminal on the indicator lamp with white or red wires with a voltmeter when the switch is in the upper position. Connect the brewer to the power source. The indication must be as described in step 2. Voltage must not be present across these terminals in the lower position.
5. Disconnect the brewer from the power source.

If voltage is present as described the switch is operating properly.

If voltage is not present as described, replace the switch.

Removal and Replacement:

1. Compress the clips inside the housing and gently push the switch through the opening.
2. Remove the wires from the switch terminals.
3. Refer to FIG. 11 when reconnecting the wires.
4. Push the new switch firmly into the opening.

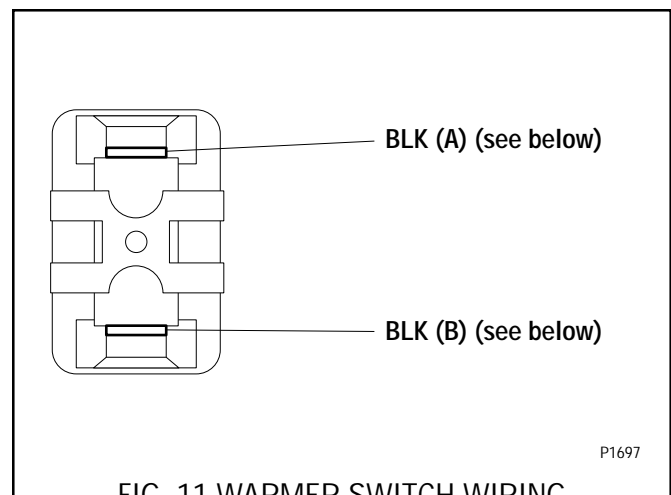

FIG. 11 WARMER SWITCH WIRING

MODEL

OL Upper	BLK A	to Warmer to Indicator Lamp
	BLK B	to Harness P3

OL On/Off Brew Station

BLK A	to Indicator Lamp to Brew Station Warmer to Level Switch
BLK B	to Terminal Block

RL On/Off Brew Station

BLK A	to Indicator Lamp to Level Switch to Brew Station Warmer
BLK B	to Left Front Warmer Switch to Right Front Warmer Switch

SERVICE (cont.)

Warmer Switch(es)

RL: Left Rear, Left Front, & Right Front

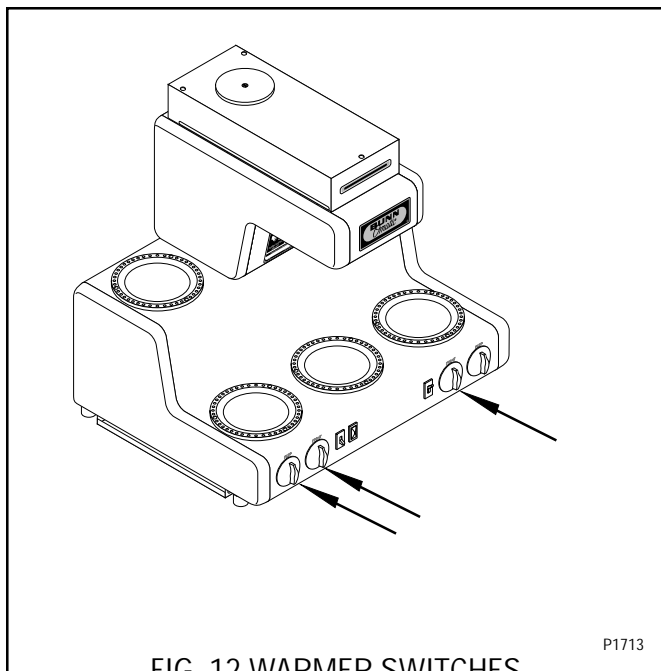

FIG. 12 WARMER SWITCHES

Location:

These warmer switches are the two at the left and the left most one on the right of the base as viewed from the front, FIG. 12. Their knobs are marked Off/On/Off/On.

To test these switches, access will also be needed to the terminal block located in the rear of the brewer.

Test Procedure:

- Check the voltage across terminal L1 and the white or red wire on the terminal block with a voltmeter. Connect the brewer to the power source. The indication must be:
 - 120 volts ac for two wire 120 volt models and three wire 120/240 volt models.
 - 200 or 240 volts ac for two wire 200 volt or 240 volt models.
 - 100 volts ac for two wire 100 volt models.
- Disconnect the brewer from the power source.

If voltage is present as described, proceed to #3.

If voltage is not present as described, refer to the Wiring Diagrams and check the brewer wiring harness.

- Check the voltage across terminal 1 and the white or red wire on the terminal block with a voltmeter when the switch is in the "ON" position. Connect the brewer to the power source. The indication must be as described in step 1. Voltage must not be present across these terminals in the "OFF" positions.
- Disconnect the brewer from the power source.

If voltage is present as described, the switch is operating properly.

If voltage is not present as described, replace the switch.

Removal and Replacement:

- Remove the knob from the switch.
- Loosen the 5/8" nut on the switch shaft and push the switch through the opening.
- Remove the wires from the switch terminals.
- Refer to FIG. 13 when reconnecting the wires.
- Securely mount the new switch onto the housing and reinstall the knob.

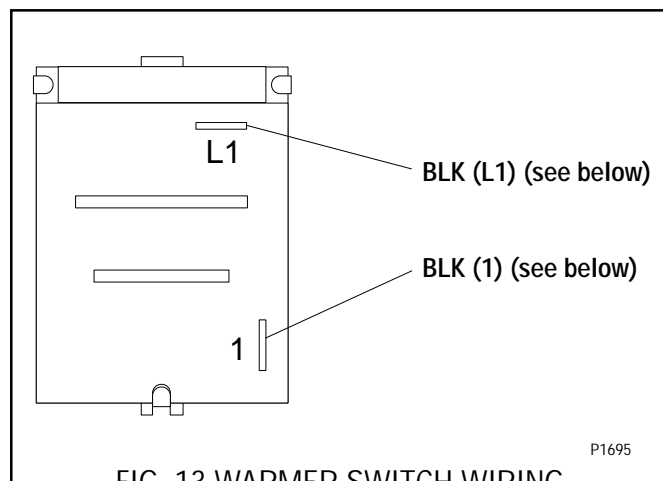

FIG. 13 WARMER SWITCH WIRING

MODEL

RT Left Rear	BLK 1	to Warmer
	BLK L1	to Left Front Warmer Switch
RT Left Front	BLK 1	to Warmer
	BLK L1	to Left Rear Warmer Switch to Brew Station Warmer Switch
RT Right Front	BLK 1	to Warmer
	BLK L1	to Terminal Block to Brew Station Warmer Switch

SERVICE (cont.)

Warmer Switch(es)

RL: Right Rear Three Heat Rotary

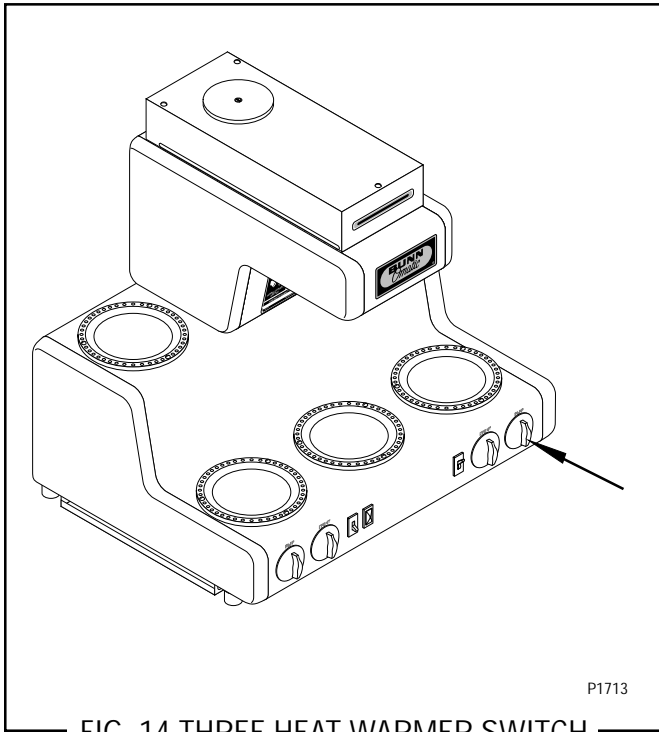

FIG. 14 THREE HEAT WARMER SWITCH

Location:

This switch is the farthest on the right of the base as viewed from the front, FIG. 14. Its knob is marked Off/Low/Med/High.

Test Procedure:

1. Check the voltage across terminals L1 and N with a voltmeter. Connect the brewer to the power source. The indication must be:
 - a) 120 volts ac for two wire 120 volt models and three wire 120/240 volt models.
 - b) 200 or 240 volts ac for two wire 200 volt or 240 volt models.
 - c) 100 volts ac for two wire 100 volt models.
2. Disconnect the brewer from the power source.

If voltage is present as described, proceed to #3.
If voltage is not present as described, refer to the Wiring Diagrams and check the brewer wiring harness.

3. Check the voltage across terminals L1 and 3 with a voltmeter when the switch is in the "Low", "Med", or "High" positions. Connect the brewer to the power source. The indication must be as described in step 1. Voltage must not be present across these terminals in the "Off" position.
4. Disconnect the brewer from the power source.

5. Check the voltage across terminals L1 and 2 with a voltmeter when the switch is in the "High" position. Connect the brewer to the power source. The indication must be as described in step 1. Voltage must not be present across these terminals in the "Off", "Low", or "Med" positions.
6. Disconnect the brewer from the power source.
7. Check the voltage across terminals N and 1 with a voltmeter when the switch is in the "Med" or "High" positions. Connect the brewer to the power source. The indication must be as described in step 1. Voltage must not be present across these terminals in the "Off" or "Low" positions.
8. Disconnect the brewer from the power source.
9. Check the voltage across terminals N and 2 with a voltmeter when the switch is in the "Low" position. Connect the brewer to the power source. The indication must be as described in step 1. Voltage must not be present across these terminals in the "Off", "Med", or "High" positions.
10. Disconnect the brewer from the power source.

If voltage is present as described, the switch is operating properly.

If voltage is not present as described, replace the switch.

Removal and Replacement:

1. Remove the knob from the switch.
2. Loosen the 5/8" nut on the switch shaft and push the switch through the opening.
3. Remove the wires from the switch terminals.
4. Refer to FIG. 15 when reconnecting the wires.
5. Securely mount the new switch onto the housing and reinstall the knob.

NOTE: Switch must be installed right side up.

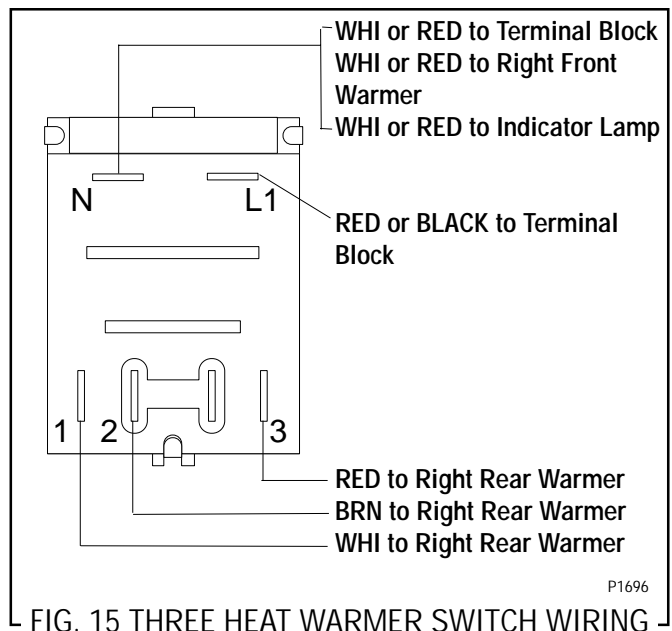
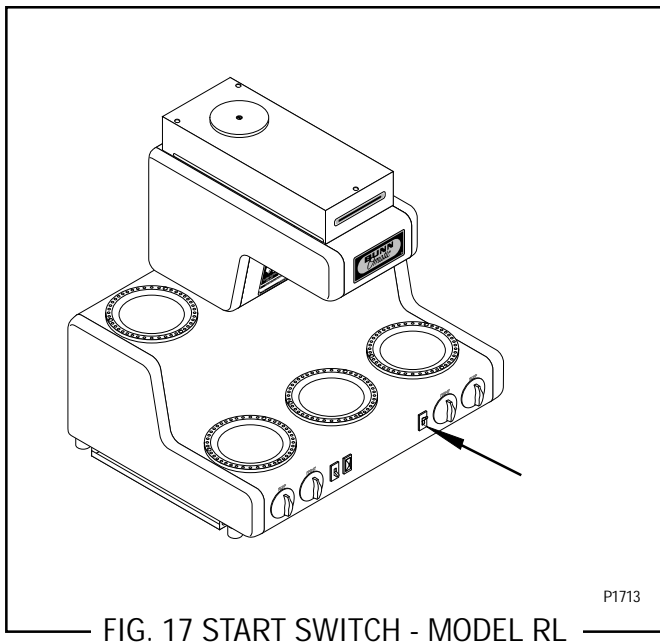
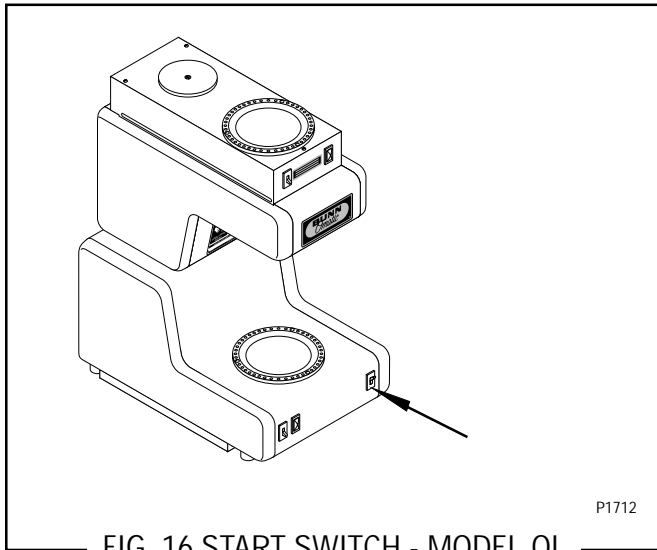

FIG. 15 THREE HEAT WARMER SWITCH WIRING

SERVICE (cont.)

Start Switch



Location:

The start switch is located in the base, below and to the right of the brew station, FIG.s 16 & 17.

Test Procedure:

1. Disconnect the brewer from the power source and remove the wires from both terminals of the start switch.
2. Check for continuity across the two terminals on the switch when it is held in the lower position. Continuity must not be present across these terminals in the upper position.

If continuity is present as described, reconnect the wires, the switch is operating properly.

If continuity is not present as described, replace the switch.

Removal and Replacement:

1. Remove all wires from the switch terminals.
2. Compress the clips inside the housing and gently push the switch through the opening.
3. Push the new switch into the opening and spread the clips to hold the switch captive in the housing.
4. Refer to FIG. 18 when reconnecting the wires.

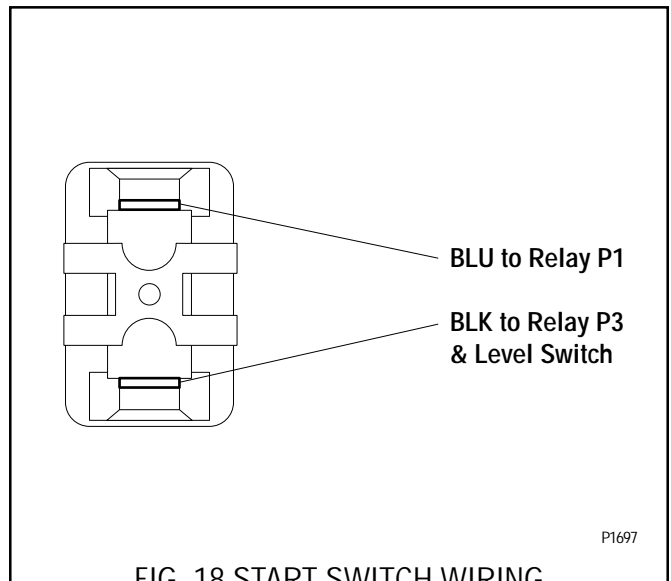

SERVICE (cont.)

Indicator Lamp(s)

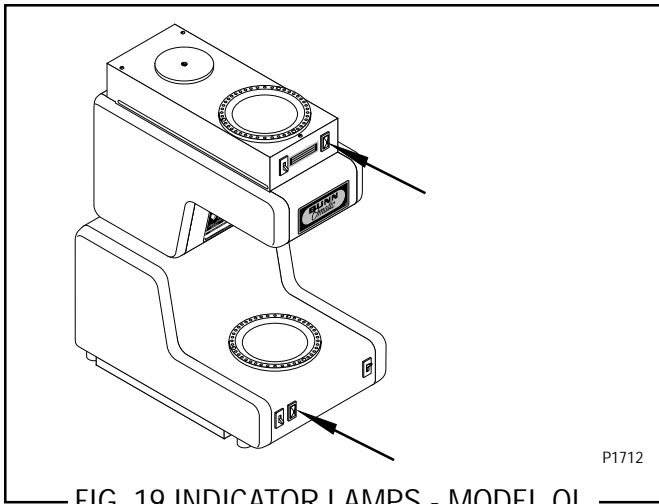

FIG. 19 INDICATOR LAMPS - MODEL OL

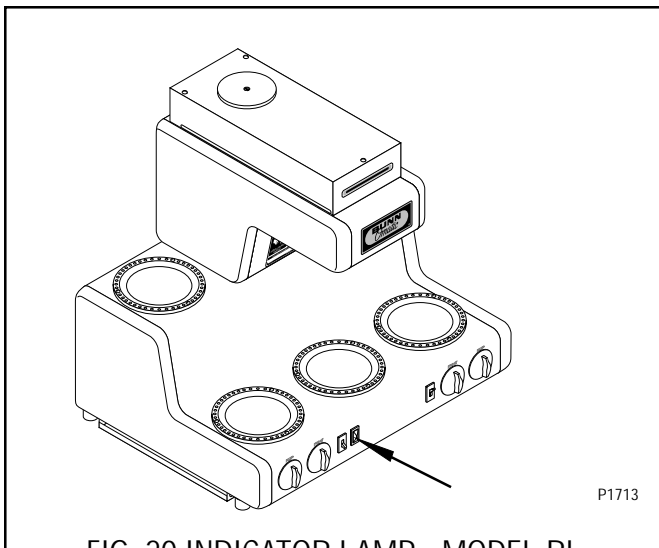

FIG. 20 INDICATOR LAMP - MODEL RL

Location:

The indicator lamps are located beneath their associated warmers, FIG.s 19 and 20.

Test Procedure:

1. Check continuity of the black wire from the switch to the indicator lamp.
2. Check continuity of the white or red wire from the indicator lamp to the terminal block.

If continuity is present, proceed to #3.

If continuity is not present, refer to Wiring Diagrams and check brewer wiring harness.

3. Check for voltage across the indicator lamp terminals. Connect the brewer to the power source. The indication must be:
 - a) 120 volts ac for two wire 120 volt models and three wire 120/240 volt models.
 - b) 200 or 240 volts ac for two wire 200 volt or 240 volt models.

- c) 100 volts ac for two wire 100 volt models.
4. Disconnect the brewer from the power source.

If voltage is present, the indicator lamp is operating properly.

If voltage is not present, replace the indicator lamp.

Removal and Replacement:

1. Compress the clips inside the housing and gently push the indicator lamp through the opening.
2. Remove the wires from the indicator lamp terminals.
3. Refer to FIG. 21 when reconnecting the wires.
4. Push the new indicator lamp firmly into the opening.

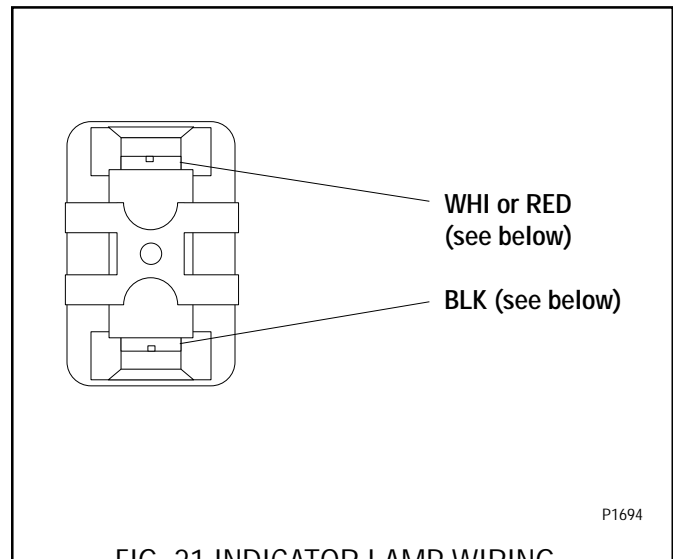
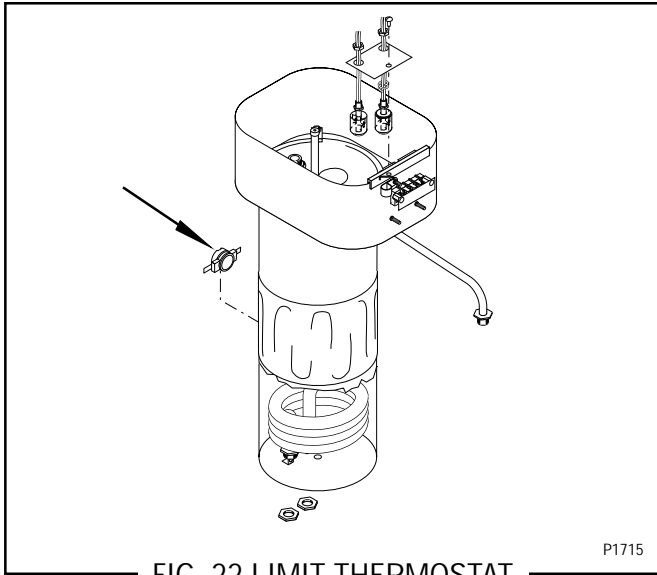

FIG. 21 INDICATOR LAMP WIRING

MODEL		
OL Upper	BLK	to Warmer Switch
	WHI or RED	to Warmer to Harness P2
OL Lower	BLK	to On/Off Brew Station Warmer Switch
	WHI or RED	to Relay P2 to Brew Station Warmer
RL	BLK	to On/Off Brew Station Warmer Switch
	WHI or RED	to Right Rear Warmer Switch to Left Front Warmer

SERVICE (cont.)

Limit Thermostat



Location:

The limit thermostat is located on the back of the tank assembly, FIG. 22.

Test Procedure:

1. Disconnect the brewer from the power source.
2. Check voltage across the black wire from the limit thermostat and the white or red wire on the tank heater terminal. Connect the brewer to the power source. The indication must be:
 - a) 120 volts ac for two wire 120 volt models.
 - b) 200 or 240 volts ac for two wire 200 volt or 240 volt models and three wire 120/240 volt models.
 - c) 100 volts ac for two wire 100 volt models.
3. Disconnect the brewer from the power source.

If voltage is present as described, proceed to #4.

If voltage is not present as described, refer to the Wiring Diagrams and check the brewer wiring harness.

4. Check for continuity across the limit thermostat terminals.

If continuity is present as described, the limit thermostat is operating properly.

If continuity is not present as described, replace the limit thermostat.

Removal and Replacement:

1. Remove both wires from the limit thermostat terminals.
2. Carefully slide the limit thermostat out from under the retaining clip.
3. Carefully slide the new limit thermostat into the retaining clip.
4. Refer to FIG. 23 when reconnecting the wires.

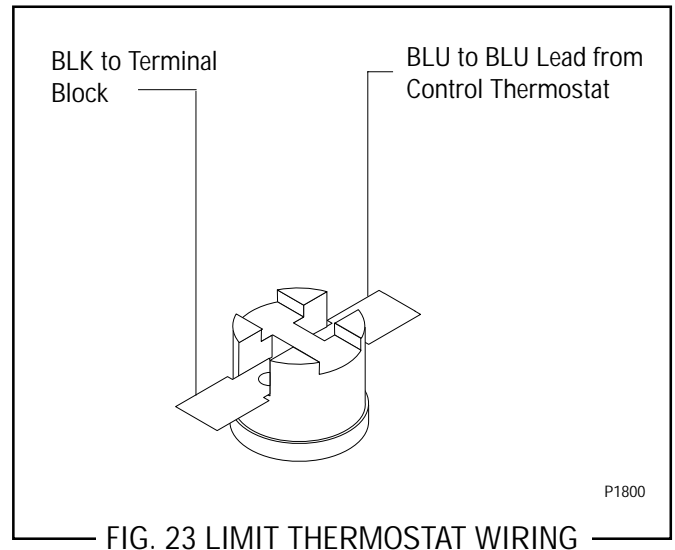

SERVICE (cont.)

Solenoid Valve

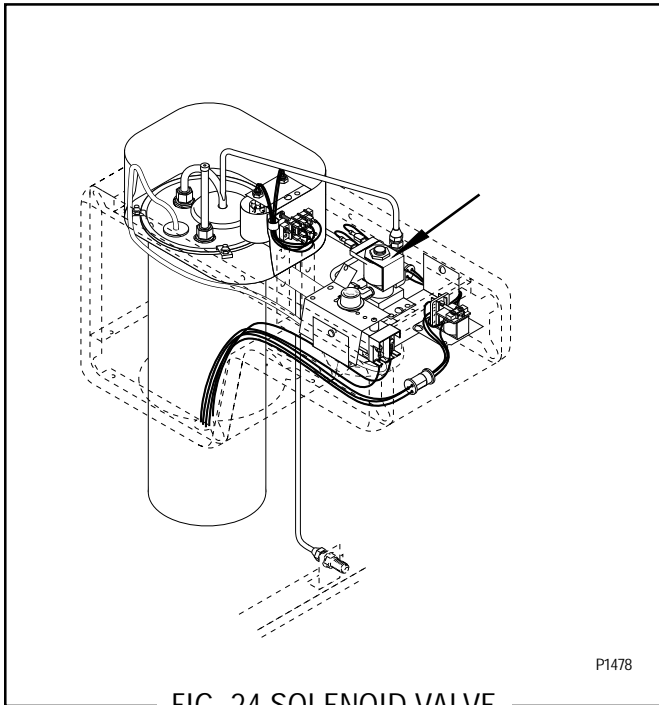

Location:

The solenoid valve is located under the top cover or top warmer housing, FIG. 24.

Test Procedure:

1. Check the voltage across the white and the black and blue wires with a voltmeter when the On/Off brew station warmer switch is in the upper position and the start switch is pressed to the lower position and released. Connect the brewer to the power source. The indication must be:
 - a) 120 volts ac for two wire 120 volt models and three wire 120/240 volt models,
 - b) 200 or 240 volts ac for two wire 200 volt or 240 volt models,
 - c) 100 volts ac for two wire 100 volt models.
2. Disconnect the brewer from the power source.

If voltage is present as described, proceed to #3.

If voltage is not present as described, refer to the Wiring Diagrams and check the brewer wiring harness.

3. Check for continuity across the solenoid valve coil terminals.

If continuity is present as described, reconnect the white and the black and blue wires and proceed to #4. If continuity is not present as described, replace the solenoid valve.

4. Check the solenoid valve for coil action. Connect the brewer to the power source, place the On/Off brew station warmer switch in the upper position, press and release the start switch. Listen carefully in the vicinity of the solenoid valve for a "clicking" sound as the coil magnet attracts and after the approximate setting of the level float switch, repels the plunger.
5. Disconnect the brewer from the power source.

If the sound is heard as described and water will not pass through the solenoid valve, there may be a blockage in the water line before or after the solenoid valve or, the solenoid valve may require inspection for wear, and removal of waterborne particles.

If the sound is not heard as described, replace the solenoid valve.

Removal and Replacement:

1. Disconnect the brewer from the power source.
2. Turn off the water supply to the brewer.
3. Remove the top cover or top warmer housing to gain access.
4. Disconnect all wires from the solenoid valve.
5. Disconnect the water lines to and from the solenoid valve.
6. Remove the two #8-32 screws which hold the solenoid valve and mounting bracket to the component bracket.
7. Lift out the solenoid valve and bracket. Remove the bracket from the solenoid valve and save to mount the new valve.
8. Securely install the new solenoid valve to the mounting bracket with two #10-32 screws. Check the direction of flow arrow on the valve. It must be pointing toward the tank inlet tube.
9. Securely attach the valve and bracket to the component bracket using the two #8-32 screws.
10. Securely fasten the water lines to and from the solenoid valve.
11. Refer to FIG. 25 when reconnecting the wires.

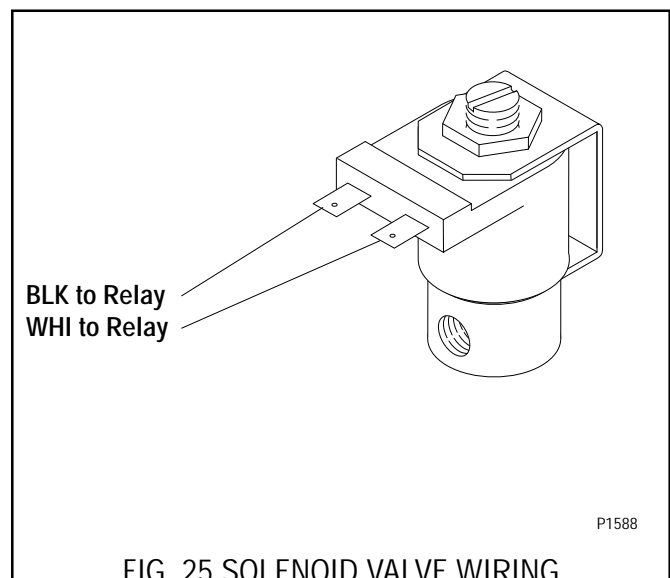

SERVICE (cont.)

Relay

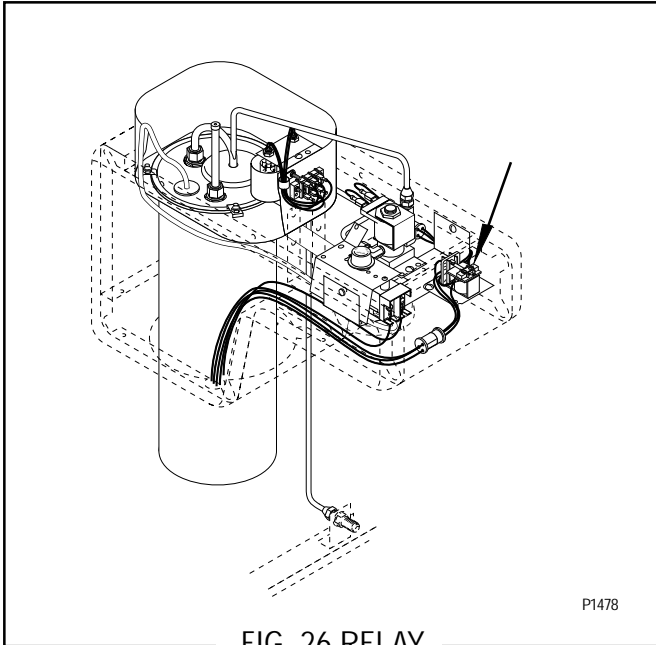

FIG. 26 RELAY

Location:

The relay is located under the top cover or top warmer housing, FIG. 26.

Test Procedure:

1. Disconnect the plug terminal from the relay to the main wiring harness. Check the voltage across the pins of the black wire (P3) and white wire (P2) on the main harness with a voltmeter when the On/Off brew station warmer switch is in the upper "ON" position. Connect the brewer to the power source. The indication must be:
 - a) 120 volts ac for two wire 120 volt models and three wire 120/240 volt models,
 - b) 200 or 240 volts ac for two wire 200 volt or 240 volt models,
 - c) 100 volts ac for two wire 100 volt models.
2. Disconnect the brewer from the power source.
3. Check the voltage across the pins of the blue wire (P1) and white wire (P2) on the main harness with a voltmeter when the On/Off brew station warmer switch is in the upper "ON" position and the start switch is pressed to the lower position and held. Connect the brewer to the power source. The indication must be as described in step 1.
4. Disconnect the brewer from the power source.

If voltage is present as described, reconnect relay plug to harness and proceed to #5.

If voltage is not present as described, refer to the Wiring Diagrams and check the brewer wiring harness.

5. Disconnect the plug terminal from the relay to the solenoid jumper wire. Check the voltage across the pins of the black wire (P3) and white wire (P2) on the relay with a voltmeter when the On/Off brew station warmer switch is in the upper "ON" position. Connect the brewer to the power source. The indication must be as described in step 1.
6. Disconnect the brewer from the power source.
7. Check the voltage across the pins of the blue wire (P1) and white wire (P2) on the relay with a voltmeter when the On/Off brew station warmer switch is in the upper "ON" position and the start switch is pressed to the lower position and released. Connect the brewer to the power source. The indication must be as described in step 1.
8. Disconnect the brewer from the power source.

If voltage is present as described, the relay is operating properly.

If voltage is not present as described, remove and replace the relay.

Removal and Replacement:

1. Disconnect the brewer from the power source.
2. Remove the top cover or top warmer housing.
3. Disconnect both plug terminals from the relay.
4. Remove the two #8-32 screws attaching the relay and bracket assembly to the component bracket.
5. Remove the #6-32 screw attaching the relay to the bracket.
6. Securely attach the new relay to the bracket using the #6-32 screw.
7. Attach the new relay and bracket assembly to the component bracket using the two #8-32 screws.
8. Reconnect the relay wire terminals to their respective plugs in the main harness and the jumper wire at the solenoid valve.

SERVICE (cont.)

Tank Heater

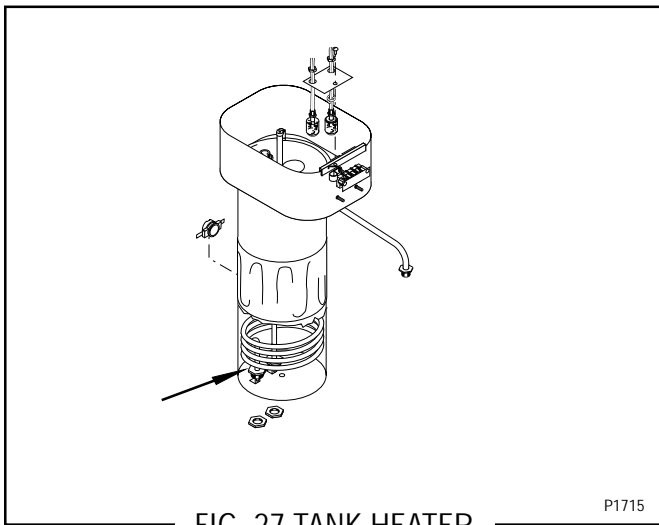

Location:

The tank heater is located in the bottom of the tank assembly, FIG. 27.

Test Procedure:

1. Check the voltage across the black and white or red wires on the tank heater with a voltmeter when the control thermostat is turned "ON" (fully clockwise). Connect the brewer to the power source. The indication must be:
 - a) 120 volts ac for two wire 120 volt models.
 - b) 200 or 240 volts ac for two wire 200 volt or 240 volt models and three wire 120/240 volt models.
 - c) 100 volts ac for two wire 100 volt models.
2. Disconnect the brewer from the power source.

If voltage is present as described, proceed to #3.
If voltage is not present as described, refer to the Wiring Diagrams and check the brewer wiring harness.

3. Check for continuity across the terminals of the tank heater.

If continuity is present as described, reconnect the wires, the tank heater is operating properly.
If continuity is not present as described, replace the tank heater.

NOTE - If the tank heater remains unable to heat, remove and inspect the heater for cracks in the sheath.

Removal and Replacement:

1. Disconnect the brewer from the power source.
2. Remove the top cover or top warmer housing and the rear access panel.
3. Disconnect the wires to the tank heater.
4. Gently pull the thermostat bulb with grommet out of the tank lid.
5. Disconnect and remove the fill basin tube.
6. Remove the four #8-32 nuts and hold-down brackets attaching the tank lid to the tank assembly and remove the tank lid and gasket.
7. Drain the water from the tank using a syphon or similar device.
8. Remove the two nuts securing the tank heater to the bottom of the tank and remove the tank heater.
9. Install a new tank heater with new washers and secure with two nuts. Nuts should be securely tightened to insure a proper seal.
10. Install the tank lid and gasket using the four hold-down brackets and #8-32 nuts.
11. Install the fill basin tube and tighten the nuts securely.
12. Slide the grommet to the red mark on the capillary tube.
13. Carefully bend the capillary tube so that the tube and bulb inside the tank are in a vertical position.
14. Insert the bulb through the hole in the tank lid and press the grommet firmly and evenly so that the groove in the grommet fits into the tank lid.
15. Refer to FIG. 28 when reconnecting the wires.
16. Refer to Initial Setup to refill the tank.

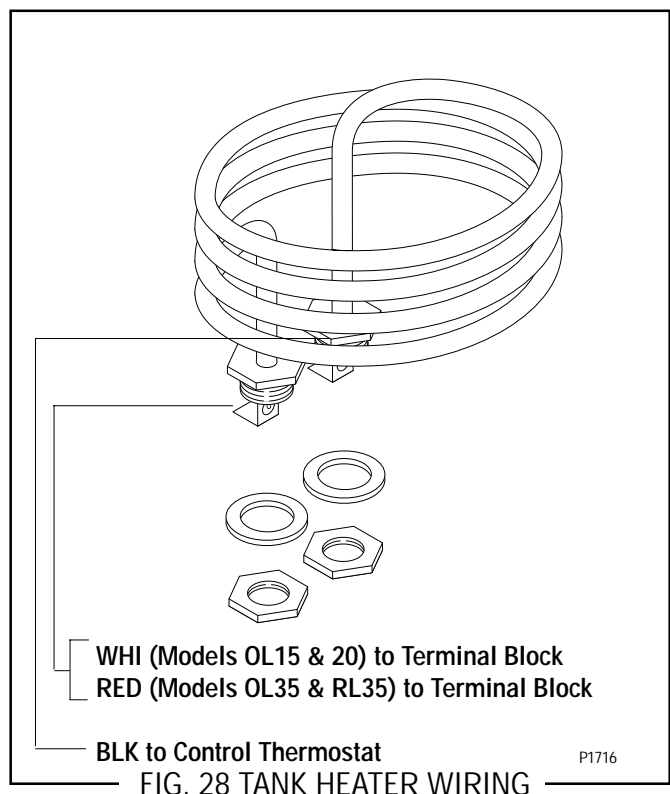

SERVICE (cont.)

Water Level and Overflow Safety Switch

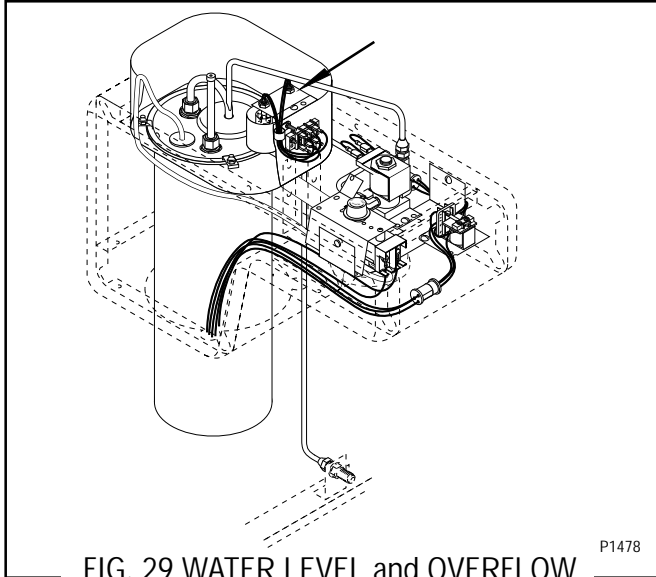

FIG. 29 WATER LEVEL and OVERFLOW SAFETY SWITCHES

Location:

The water level and overflow safety switches are located under the top cover or top warmer housing and inside and front of the tank fill basin, FIG. 29.

Test Procedure:

1. Disconnect the brewer from the power source.
2. Remove the top cover or top warmer housing.
3. Remove the leads of the switch being tested from the connection block mounted on the front of the tank basin.
4. Check the voltage across each black lead of the connection block and the white or red lead on the solenoid coil with a voltmeter. Turn the ON/OFF switch to the "ON" position and connect the brewer to the power source. The indication must be:
 - a) 120 volts ac for two wire 120 volt models and three wire 120/240 volt models,
 - b) 200 or 240 volts ac for two wire 200 volt or 240 volt models,
 - c) 100 volts ac for two wire 100 volt models.
5. Disconnect the brewer from the power source.

If voltage is present as described, proceed to #6.

If voltage is not present as described, refer to the Wiring Diagrams and check the brewer wiring harness.

6. Check for continuity across the overflow switch pink wires only until the plastic float is raised and check that continuity returns when the float is lowered again.
7. Check for continuity across the water level switch pink wires only until the plastic float is raised and check that continuity returns when the float is lowered again.

If continuity is present as described, reconnect the wires as shown in FIG. 30, the switches are operating properly.

If continuity is not present as described, replace the failed switch.

Removal and Replacement:

1. Disconnect the brewer from the power source.
2. Remove the top cover or top warmer housing.
3. Remove the wire leads connecting the water level and overflow switches to the terminal block at the front of the tank and fill basin.
4. Disconnect the #8-32 screw and remove the entire switch assembly from the tank and fill basin.
5. Place the new switch assembly into the bracket, wires up.

NOTE- The magnets must be at the top of the float and there must be NO adjusting washers installed for the overflow safety switch to operate properly.

6. Install the nuts over the wires and secure the switch to the mounting bracket. Do not over tighten.
7. Attach the entire switch assembly to the tank and fill basin using the #8-32 screw.
8. Add or remove washers to the float on the level switch as required. Adding washers increases the volume, removing washers decreases it.
9. Refer to FIG. 30 and the relative wiring diagram when reconnecting wires.

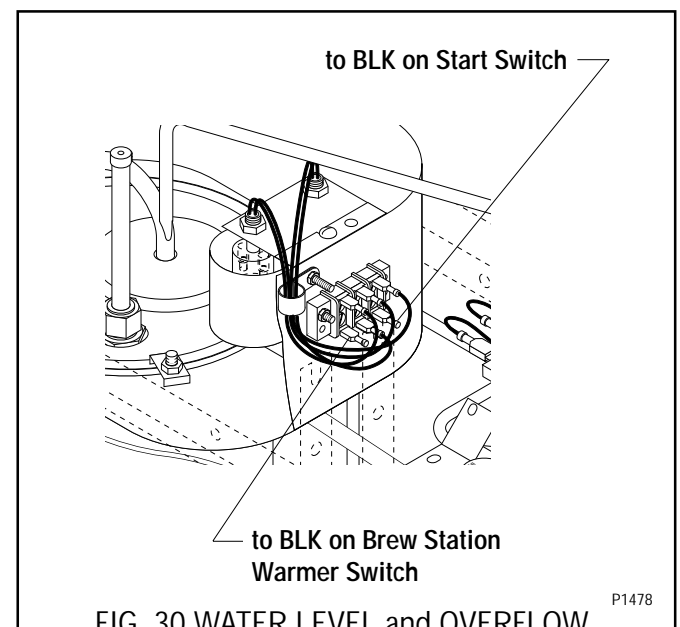
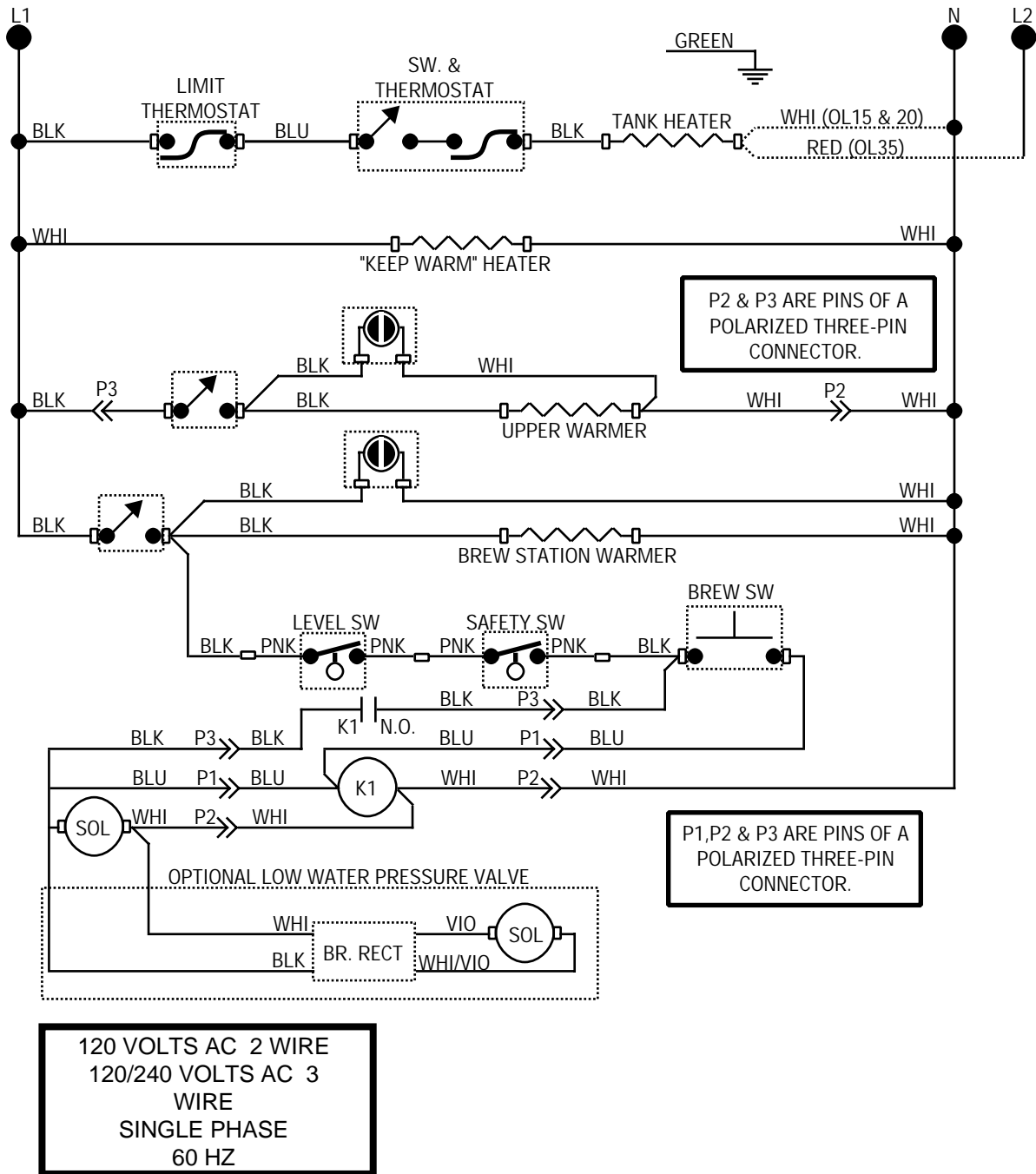
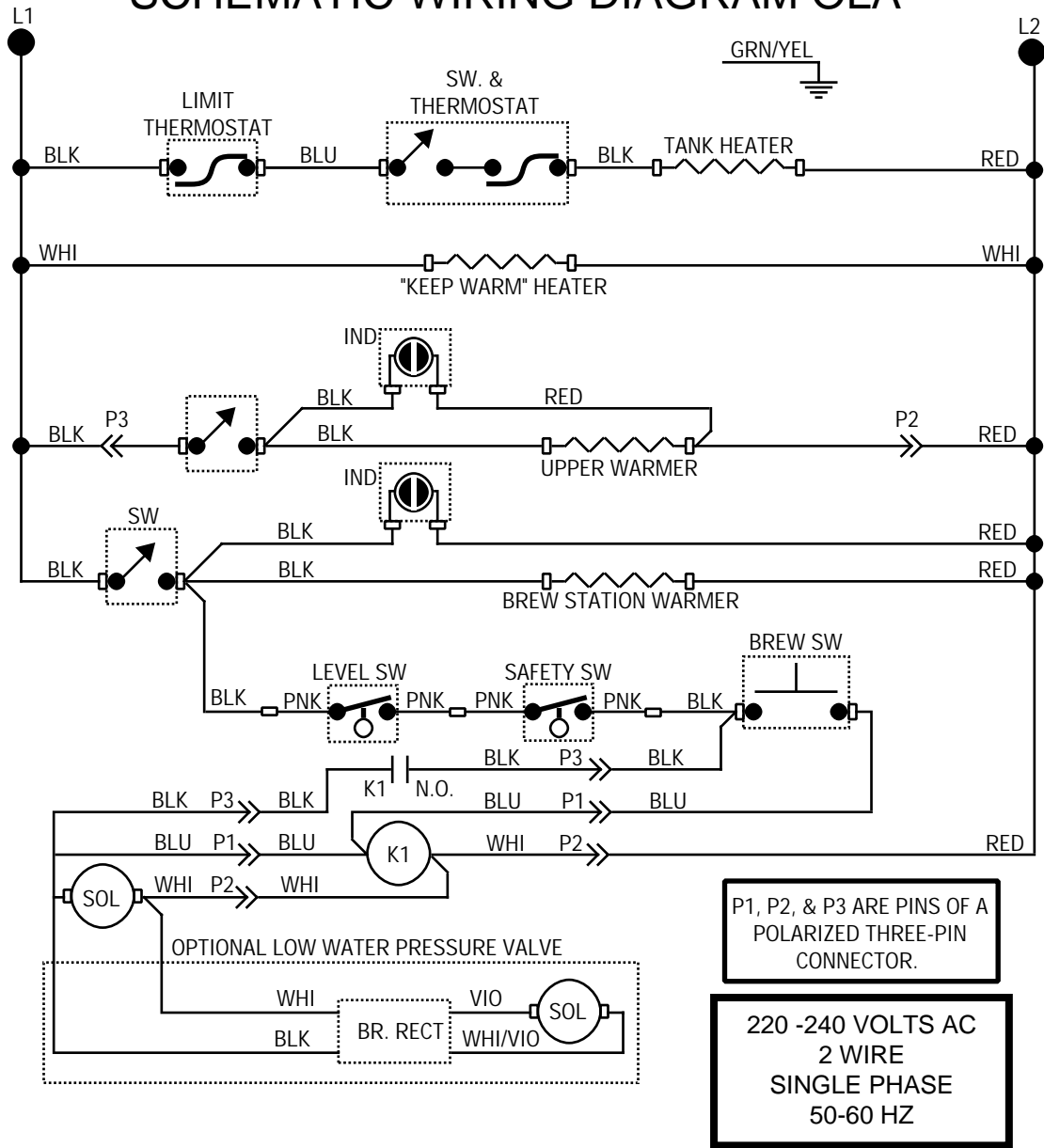

FIG. 30 WATER LEVEL and OVERFLOW SAFETY SWITCH WIRING

SCHEMATIC WIRING DIAGRAM OL



SCHEMATIC WIRING DIAGRAM OLA



P1, P2, & P3 ARE PINS OF A POLARIZED THREE-PIN CONNECTOR.

220 -240 VOLTS AC
2 WIRE
SINGLE PHASE
50-60 HZ

SCHEMATIC WIRING DIAGRAM OL25B

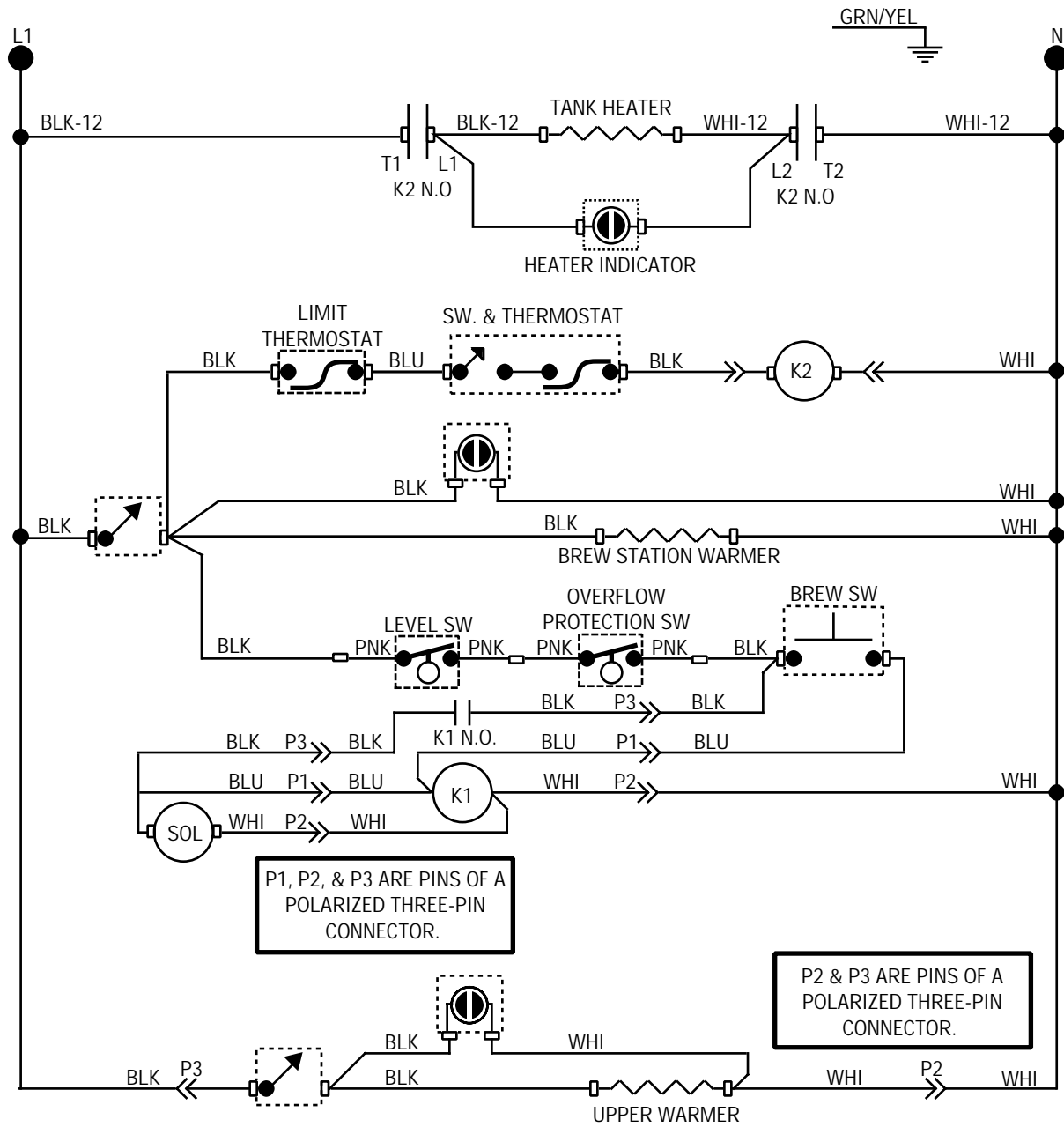

P1, P2, & P3 ARE PINS OF A POLARIZED THREE-PIN CONNECTOR.

P2 & P3 ARE PINS OF A POLARIZED THREE-PIN CONNECTOR.

100 VOLTS AC
2 WIRE
SINGLE PHASE
50/60 HZ

SCHEMATIC WIRING DIAGRAM OL35B

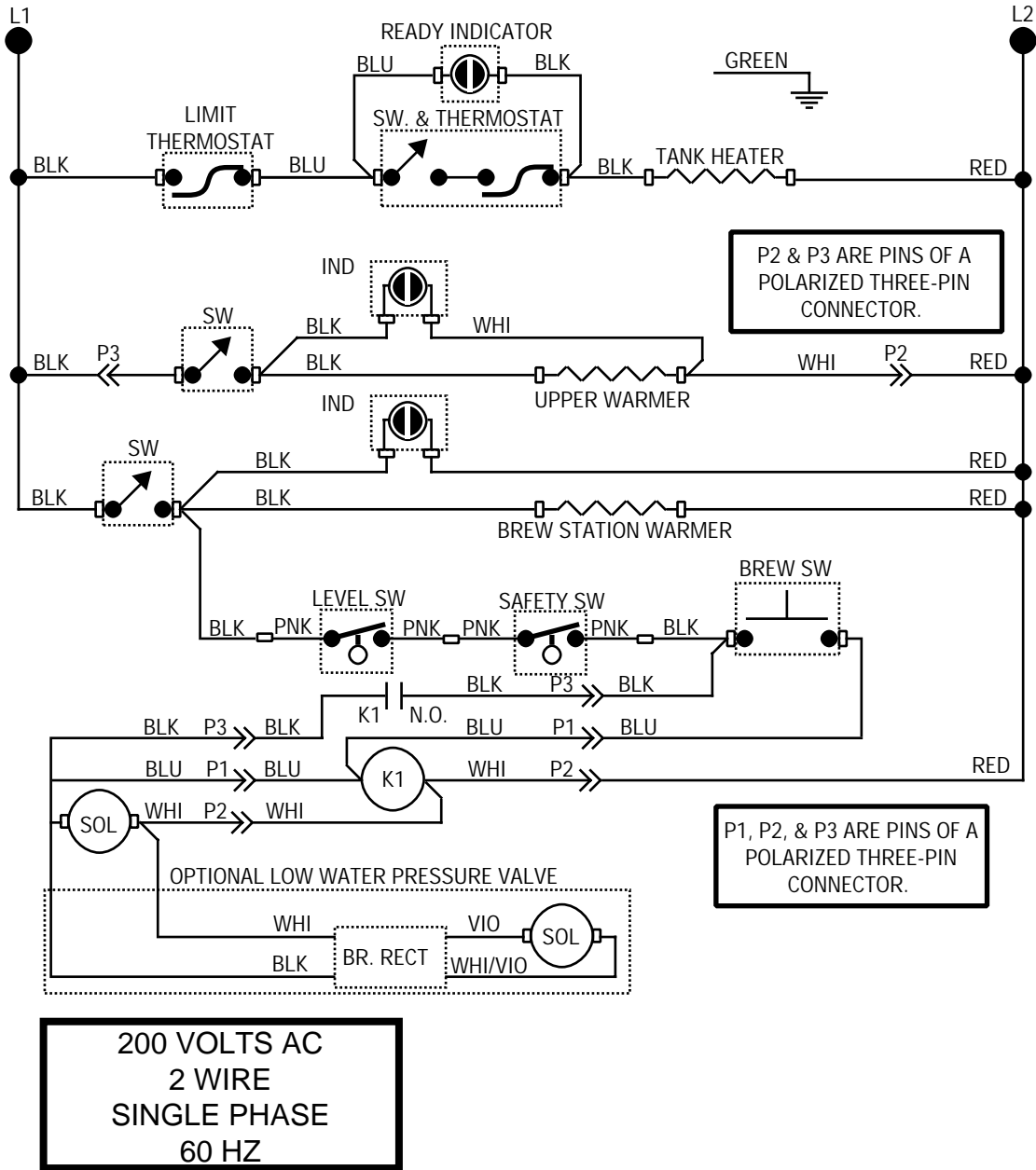

SCHEMATIC WIRING DIAGRAM RL

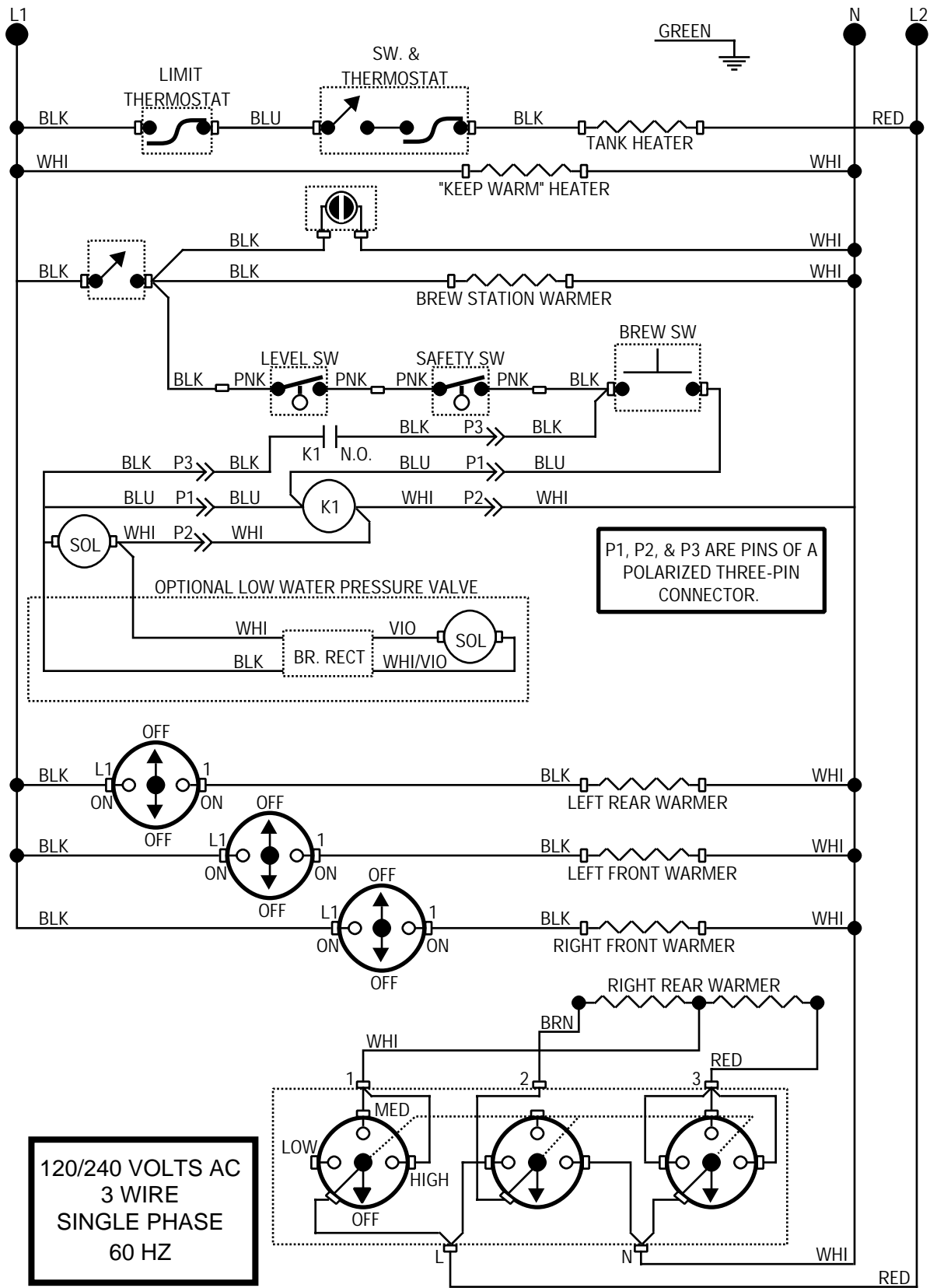

SCHEMATIC WIRING DIAGRAM RLA

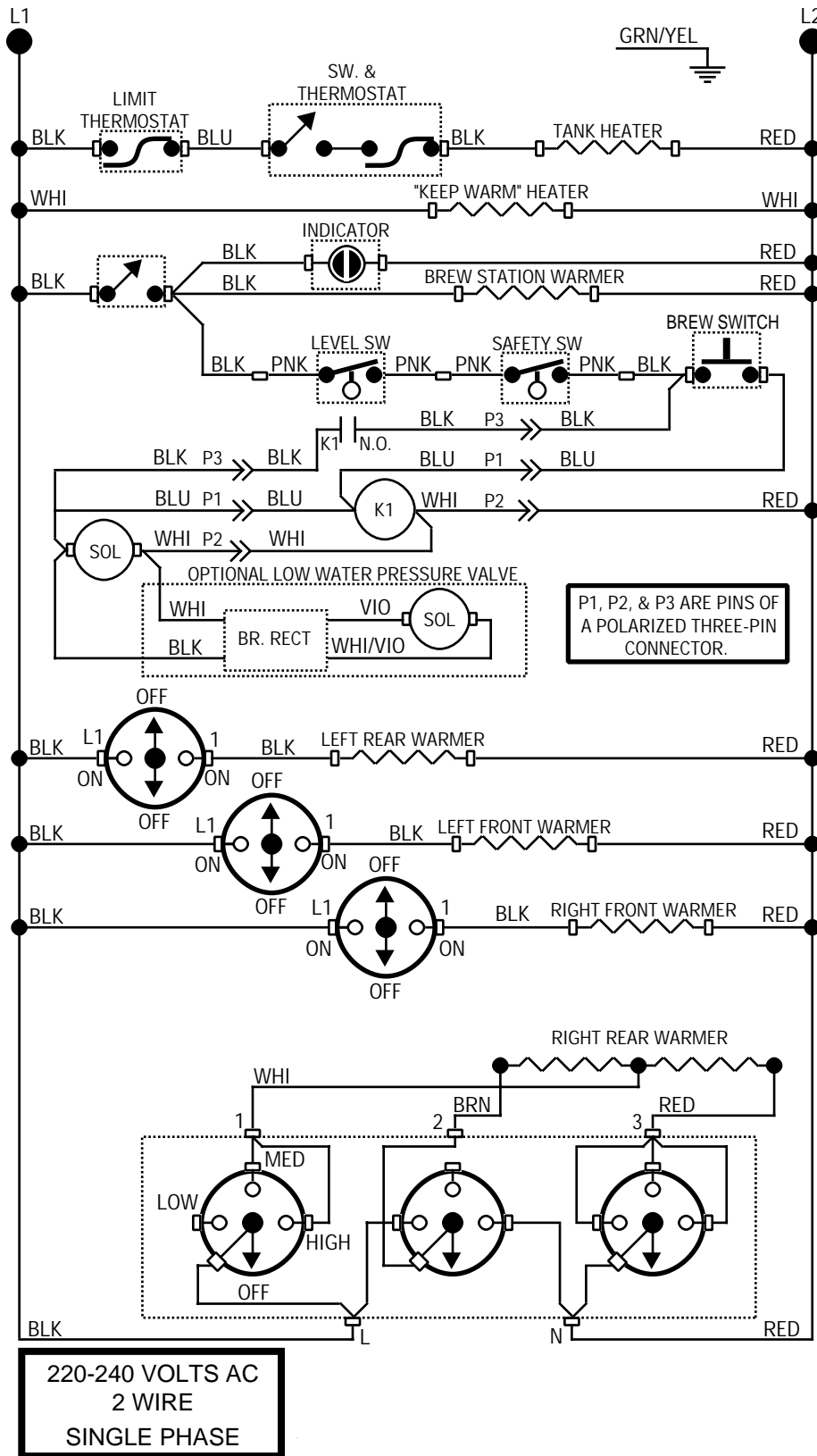

SCHEMATIC WIRING DIAGRAM RL25B

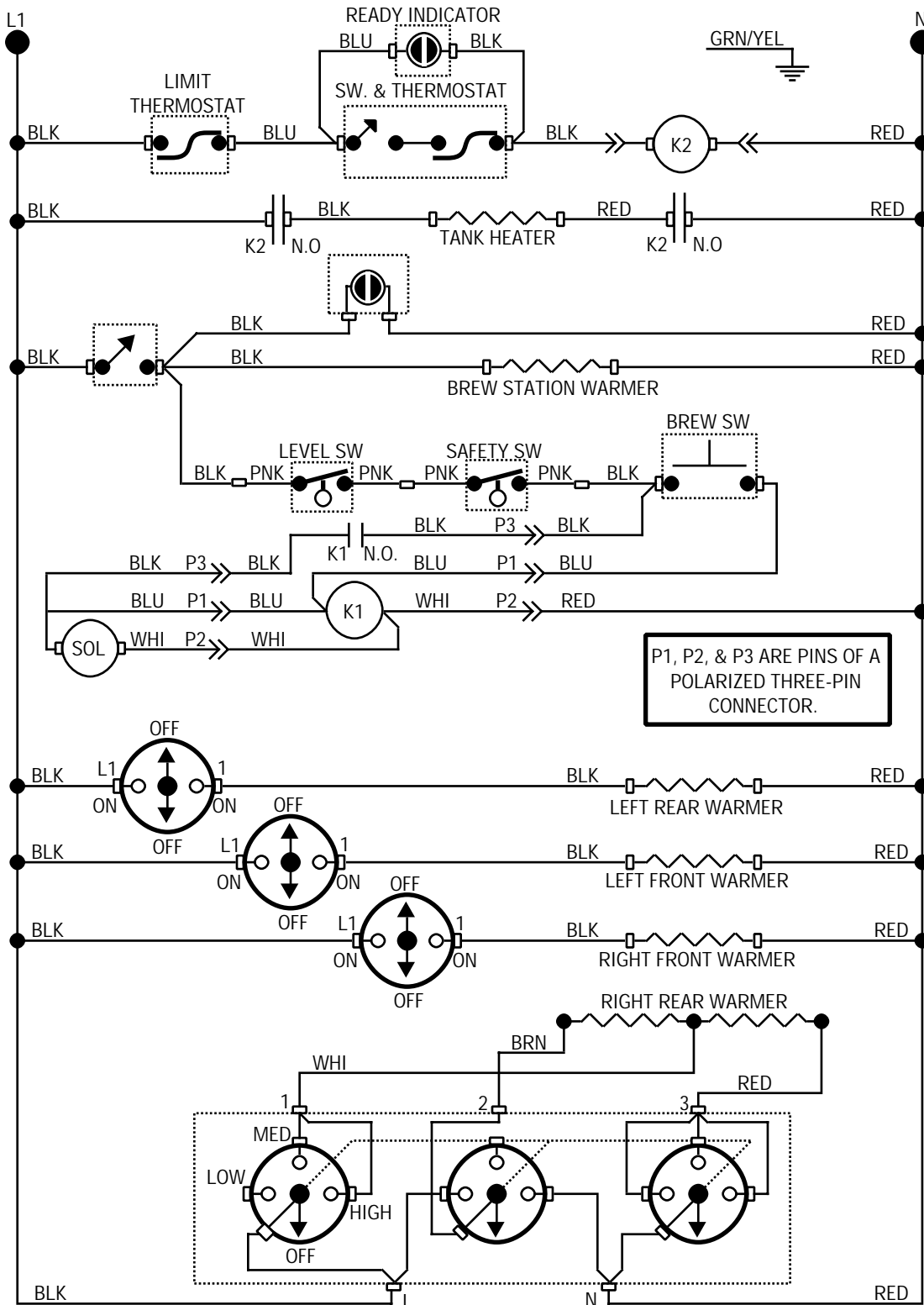

100 VOLTS AC
2 WIRE
SINGLE PHASE
60 HZ

SCHEMATIC WIRING DIAGRAM RL35B

