

BUNN®

VLPF

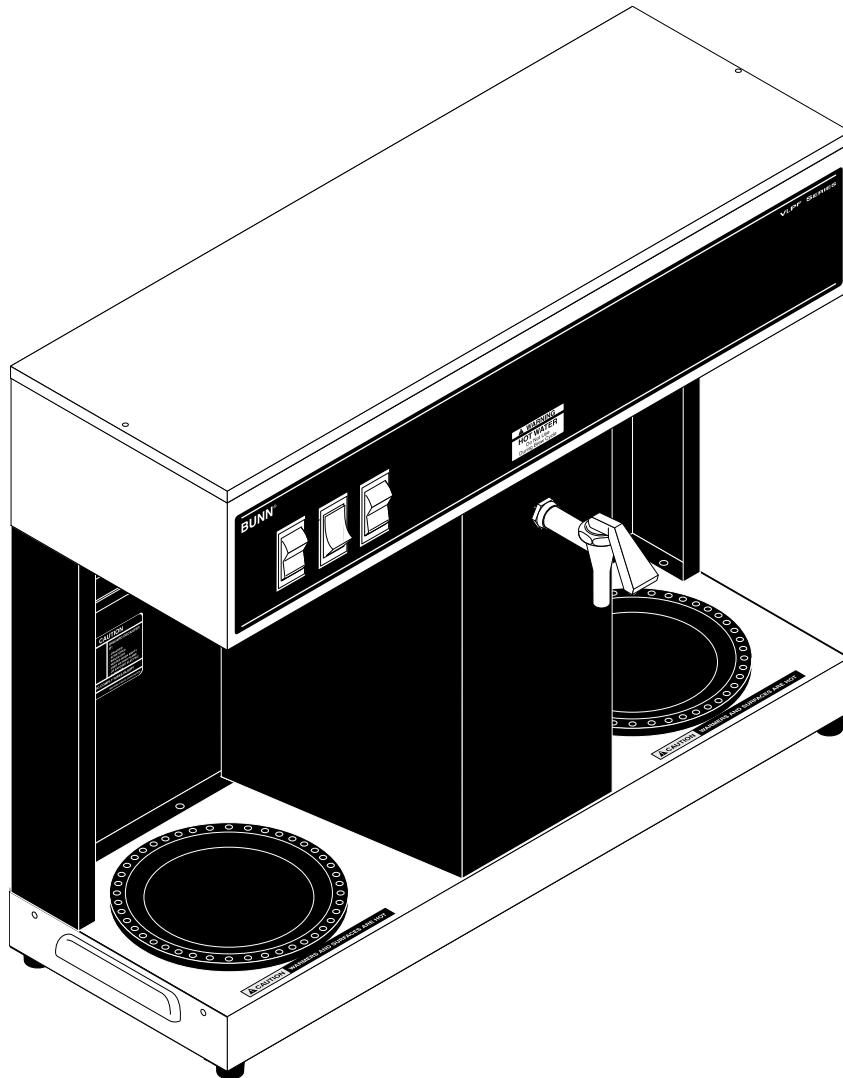

OPERATING & SERVICE MANUAL

BUNN-O-MATIC CORPORATION

OF CANADA

**280 INDUSTRIAL PARKWAY SOUTH,
AURORA, ONTARIO, L4G 3T9.
PHONE: (905) 841-2866 FAX: (905) 841-2775**

BUNN-O-MATIC COMMERCIAL PRODUCT WARRANTY

Bunn-O-Matic Corporation of Canada (“Bunn”) warrants equipment manufactured by it as follows:

- 1) Airpots, thermal carafes, decanters, GPR servers, iced tea/coffee dispensers, MCP/MCA pod brewers thermal servers and Thermofresh servers (mechanical and digital) - 1 year parts and 1 year labour.
- 2) All other equipment - 2 years parts and 1 year labour plus added warranties as specified below:
 - a) Electronic circuit and/or control boards - parts and labour for 3 years.
 - b) Compressors on refrigeration equipment - 5 years parts and 1 year labour.
 - c) Grinding burrs on coffee grinding equipment to grind coffee to meet original factory screen sieve analysis - parts and labour for 4 years or 40,000 pounds of coffee, whichever comes first.

These warranty periods run from the date of installation. Bunn warrants that the equipment manufactured by it will be commercially free of defects in material and workmanship existing at the time of manufacture and appearing within the applicable warranty period. This warranty does not apply to any equipment, component or part that was not manufactured by Bunn or that, in Bunn’s judgement, has been affected by misuse, neglect, alteration, improper installation or operation, improper maintenance or repair, non periodic cleaning and descaling, equipment failures related to poor water quality, damage or casualty. In addition, the warranty does not apply to replacement of items subject to normal use including but not limited to user replaceable parts such as seals and gaskets. This warranty is conditioned on the Buyer 1) giving Bunn prompt notice of any claim to be made under this warranty by telephone at (905) 841-2866 or by writing to 280 Industrial Parkway South, Aurora, Ontario, L4G 3T9. 2) if requested by Bunn, shipping the defective equipment prepaid to an authorized Bunn service location; and 3) receiving prior authorization from Bunn that the defective equipment is under warranty.

THE FOREGOING WARRANTY IS EXCLUSIVE AND IS IN LIEU OF ANY OTHER WARRANTY, CONDITION, WRITTEN OR ORAL, EXPRESS OR IMPLIED, INCLUDING, BUT NOT LIMITED TO, ANY IMPLIED WARRANTY OF EITHER MERCHANTABILITY, MERCHANTABILITY QUALITY OR FITNESS FOR A PARTICULAR PURPOSE. The agents, dealers or employees of Bunn are not authorized to make modifications to this warranty or to make additional warranties that are binding on Bunn. Accordingly, statements by such individuals, whether oral or written, do not constitute warranties and should not be relied upon.

If Bunn determines in its sole discretion that the defective equipment is covered by warranty, Bunn, at its exclusive option while the equipment is under warranty, shall either 1) provide at no charge replacement parts and/or labour (during the applicable parts and labour warranty periods specified above) to repair the defective components, provided that this repair is done by a Bunn Authorized Service Representative; or 2) shall replace the equipment or refund the purchase price for the equipment.

THE BUYER’S REMEDY AGAINST BUNN FOR THE BREACH OF ANY OBLIGATION ARISING OUT OF THE SALE OF THIS EQUIPMENT, WHETHER DERIVED FROM WARRANTY OR OTHERWISE, SHALL BE LIMITED, AT BUNN’S SOLE OPTION AS SPECIFIED HEREIN, TO REPAIR, REPLACEMENT OR REFUND.

In no event shall Bunn be liable for any other damage or loss, including, but not limited to, lost profits, lost sales, loss of use of equipment, claims of Buyer’s customers, cost of capital, cost of down time, cost of substitute equipment, facilities or services, or any other special, incidental, consequential or punitive damages.

RETURN POLICY

CONTACT PLANT FOR RETURN MATERIAL AUTHORIZATION. ALL RETURNS MUST BE AUTHORIZED BY BUNN-O-MATIC AND ARE SUBJECT TO A RETURN CHARGE.

392, AutoPOD, AXIOM, BrewLOGIC, BrewMETER, Brew Better Not Bitter, BrewWISE, BrewWIZARD, BUNN Espresso, BUNN Family Gourmet, BUNN Gourmet, BUNN Pour-O-Matic, BUNN, BUNN with the stylized red line, BUNNlink, Bunn-O-Matic, Bunn-O-Matic, BUNNserve, BUNNSERVE with the stylized wrench design, Cool Froth, DBC, Dr. Brew stylized Dr. design, Dual, Easy Pour, EasyClear, EasyGard, FlavorGard, Gourmet Ice, Gourmet Juice, High Intensity, iMIX, Infusion Series, Intellisteam, My Café, Phase Brew, PowerLogic, Quality Beverage Equipment Worldwide, Respect Earth, Respect Earth with the stylized leaf and coffee cherry design, Safety-Fresh, savemycoffee.com, Scale-Pro, Silver Series, Single, Smart Funnel, Smart Hopper, SmartWAVE, Soft Heat, SplashGard, The Mark of Quality in Beverage Equipment Worldwide, ThermoFresh, Titan, trifecta, Velocity Brew, A Partner You Can Count On, Air Brew, Air Infusion, Beverage Bar Creator, Beverage Profit Calculator, Brew better, not bitter., BUNNSource, Coffee At Its Best, Cyclonic Heating System, Daypart, Digital Brewer Control, Nothing Brews Like a BUNN, Pouring Profits, Signature Series, Tea At Its Best, The Horizontal Red Line, Ultra are either trademarks or registered trademarks of Bunn-O-Matic Corporation.

USER NOTICES

Carefully read and follow all notices on the equipment and in this manual. They were written for your protection. All notices on the equipment should be kept in good condition. Replace any unreadable or damaged labels.

#00656.0000

This equipment is to be installed to comply with the Basic Plumbing Code of the Building Officials and Code Administrators International, Inc. (BOCA) and the Food Service Sanitation Manual of the Food and Drug Administration (FDA).

#00658.7000

WARNING

FUNNEL CONTENTS ARE HOT

DISCARD DECANTER IF:

- CRACKED
- SCRATCHED
- BOILED DRY
- HEATED WHEN EMPTY
- USED ON HIGH FLAME OR EXPOSED ELECTRIC ELEMENTS

READ THE ENTIRE OPERATING MANUAL BEFORE USING THIS PRODUCT
FAILURE TO COMPLY RISKS INJURY

PN: 00658.0000F 6/98 © 1985 BUNN-O-MATIC CORPORATION

#00831.0002

WARNING

- ◆ **Fill water tank before turning - on - thermostat or connecting appliance to power source.**
- ◆ **Use only on a properly protected circuit capable of the rated load.**
- ◆ **Electrically ground the chassis.**
- ◆ **Follow national/local electrical codes.**
- ◆ **Do not use near combustibles.**

FAILURE TO COMPLY RISKS EQUIPMENT DAMAGE, FIRE, OR SHOCK HAZARD

READ THE ENTIRE OPERATING MANUAL BEFORE BUYING OR USING THIS PRODUCT

THIS APPLIANCE IS HEATED WHENEVER CONNECTED TO A POWER SOURCE

00831.0000F 3/98 ©1998 BUNN-O-MATIC CORPORATION

#00882.7000

WARNING

HOT WATER
Do Not Use
During Brew Cycle

#12364.7000

CAUTION

WARMERS AND SURFACES ARE HOT

ELECTRICAL REQUIREMENTS

CAUTION - The brewer must be disconnected from the power source until specified in Initial Set-Up.

The brewer has an attached cordset and requires 2-wire, grounded service rated 120 volts ac, 15 amp, single phase, 60 Hz.

PLUMBING REQUIREMENTS

This brewer must be connected to a cold water system with operating pressure between 20(138) and 90 psi(620 kPa) from a 1/2" or larger supply line. A shut-off valve should be installed in the line before the brewer. Install a regulator in the line when pressure is greater than 90 psi(620 kPa) to reduce it to 50 psi(345 kPa). The water inlet fitting is 1/4" flare.

NOTE - Bunn-O-Matic recommends 1/4" copper tubing for installations of less than 25 feet and 3/8" for more than 25 feet from the 1/2" water supply line. A tight coil of copper tubing in the water line will facilitate moving the brewer to clean the countertop. Bunn-O-Matic does not recommend the use of a saddle valve to install the brewer. The size and shape of the hole made in the supply line by this type of device may restrict water flow.

Plumbing Hook-Up

1. **Attach the female fitting from the short piece of tubing on the flow control/strainer assembly (supplied) to the water inlet fitting on the right rear side of the brewer.**
2. **Flush the water line and securely attach it to the flare fitting on the flow control/strainer assembly.**
3. **Turn on the water supply**

This equipment must be installed to comply with the Basic Plumbing Code of the Building Officials and Code Administrators International, Inc. (BOCA) and the Food Service Sanitation Manual of the Food and Drug Administration (FDA).

OPERATING CONTROLS

A. On/Left Switch

Placing the switch in the upper position supplies power to the left decanter warmer and enables brewing and refilling of the tank. Placing the switch in the lower position cuts power to the left decanter warmer and stops brewing and refilling of the tank. Stopping a brew cycle after it has been started will not stop the flow of water into the funnel until the tank syphons down to its proper level.

NOTE - The On/Left switch must be in the upper position to initiate and complete a brew cycle or to automatically refill the tank after using the hot water faucet.

B. Start Switch

Starts a brew cycle when the On/Left switch is in the upper position.

C. Right Switch

Placing the switch in the upper position supplies power to the right decanter warmer. Placing the switch in the lower position cuts power to the right decanter warmer.

INITIAL SET-UP

CAUTION - The brewer must be unplugged throughout the *Initial Set-up*, except when specified in the instructions.

1. Remove the top lid from the brewer.
2. Rotate the control thermostat knob fully counterclockwise to the “OFF” position and replace the top lid.
3. Insert an empty funnel into the funnel rails.
4. Place a decanter containing a small amount of water on the left warmer.
5. Plug in the brewer and place the On/Left switch in the upper position. Water will flow into the tank after a five second delay and continue until the tank has filled to its capacity. This should take approximately seven minutes.

NOTE - The On/left switch must be in the upper position to initiate and complete a brew cycle or to automatically refill the tank after using the hot water faucet.

6. Place the On/left switch in the lower position.
7. Unplug the brewer.
8. Remove the top lid.
9. Rotate the control thermostat knob fully clockwise to the “ON” position and replace the top lid.
10. Plug in the brewer and wait for the water in the tank to heat to the proper temperature. Some water will drip from the funnel during this time. This is due to expansion and should not occur thereafter.
11. Place an empty decanter under the funnel.
12. Place the On/Left switch in the upper position and press the Start switch. Empty the decanter after water has stopped flowing from the funnel.
13. Allow the water in the tank to reheat to the proper temperature.
14. Press the Start switch. Check the water volume in the decanter after water has stopped flowing from the funnel. It should be 64 ounces.
15. If not, unplug the brewer and remove the top lid.
16. Adjust the brew timer as required. See *Adjusting Brew Volumes*. Replace the top lid, plug in the brewer, start, and measure another brew cycle.
17. Repeat steps 13-16 until 64 oz. water volume is achieved.

ADJUSTING BREW VOLUMES

CAUTION - Disconnect the power source from the brewer prior to the removal of any panel for the replacement or adjustment of any component.

NOTE: Prior to setting or modifying batch sizes, check that the brewer is connected to water supply, the tank is properly filled, and a funnel and server are in place.

1. **Modifying batch sizes.** To modify a batch volume, first check that the SET/LOCK switch is in the “SET” position on the circuit board.

To increase a batch size. Press and hold the START or BREW switch until three clicks are heard. Release the switch (Failure to release the switch within two seconds after the third click causes the volume setting to be aborted and previous volume setting will remain in memory) and press it again one or more times. Each time the switch is pressed, two seconds are added to the brew time period. Allow the brew cycle to finish in order to verify that the desired volume has been achieved.

To decrease a batch size. Press and release the START or BREW switch once for every two-second interval to be removed from the total brew time period; then immediately press and hold down the START or BREW switch until three clicks are heard. Release the switch. (Failure to release the switch within two seconds after the third click causes the volume setting to be aborted and previous volume setting will remain in memory). Allow the brew cycle to finish in order to verify that the desired volume has been achieved.

ADJUSTING BREW VOLUMES(cont)

2. **Setting batch sizes.** To set a batch volume, first check that the SET/LOCK switch is in the “SET” position on the circuit board. Press and hold the START or BREW switch until three distinct clicks are heard, and then release the switch. (Failure to release the switch within two seconds after the third click causes the volume setting to be aborted and previous volume setting will remain in memory). View the level of the liquid being dispensed. When the desired level is reached, turn the ON/OFF switch to “OFF”. The brewer remembers this volume and will continue to brew batches of this size until the volume setting procedure is repeated.

NOTE: When brewing coffee, batch volumes will decrease due to absorption by the coffee grounds.

3. **Setting programming disable feature.** If it becomes necessary to prevent anyone from changing brew times once programmed, you can set the SET/LOCK switch to the “LOCK” position. This will prevent any programming to be done until switch is once again placed in the “SET” position.

COFFEE BREWING

1. Insert a BUNN® filter into the funnel.
2. Pour the fresh coffee into the filter and level the bed of grounds by gently shaking.
3. Slide the funnel into the funnel rails.
4. Place the On/Left switch in the upper position.
5. Press the Start switch.
6. When brewing is completed, simply discard the grounds and filter.

NOTE - Any attempt to draw hot water from the faucet during a brew cycle will result in a lesser amount of finished beverage in the decanter.

CLEANING

1. The use of a damp cloth rinsed in any mild, non-abrasive, liquid detergent is recommended for cleaning all surfaces on Bunn-O-Matic equipment.
2. Check and clean the sprayhead. The sprayhead holes must always remain open.
3. With the sprayhead removed, insert the deliming spring (provided) all the way into the sprayhead tube. When inserted properly, no more than two inches of spring should be visible. Saw back and forth five or six times. Then, repeat this step for the airvent tube.

NOTE - In hard water areas, this may need to be done daily. It will help prevent liming problems in the brewer and takes less than a minute.

TROUBLESHOOTING

A troubleshooting guide is provided to suggest probable causes and remedies for the most likely problems encountered. If the problem remains after exhausting the troubleshooting steps, contact the Bunn-O-Matic Technical Services Department.

- Inspection, testing, and repair of electrical equipment should be performed only by qualified service personnel.
- All electronic components have 120 volt ac and low voltage dc potential on their terminals. Shorting of terminals or the application of external voltages may result in board failure.
- Intermittent operation of electronic circuit boards is unlikely. Board failure will normally be permanent. If an intermittent condition is encountered, the cause will likely be a switch contact or a loose connection at a terminal or crimp.
- Solenoid removal requires interrupting the water supply to the valve. Damage may result if solenoids are energized for more than ten minutes without a supply of water.
- The use of two wrenches is recommended whenever plumbing fittings are tightened or loosened. This will help to avoid twists and kinks in the tubing.
- Make certain that all plumbing connections are sealed and electrical connections tight and isolated.
- This brewer is heated at all times unless unplugged. Keep away from combustibles.

WARNING

- **Exercise extreme caution when servicing electrical equipment.**
- **Unplug the brewer when servicing, except when electrical tests are specified.**
- **Follow recommended service procedures.**
- **Replace all protective shields or safety notices.**

TROUBLESHOOTING (cont.)

PROBLEM	PROBABLE CAUSE	REMEDY
Equipment will not operate	1. No power or incorrect voltage	(A) Plug in brewer. (B) Check wall outlet for 120V ac (C) Check circuit breaker/fuse.
Brew cycle will not start	1. No water	Check plumbing and shut-off valves.
	2. Water strainer/Flow Control	(A) Direction of flow arrow must be pointing towards brewer. (B) Remove the strainer/Flow control and check for obstructions. Clear or replace.
	3. On/Left switch	Refer to Service - On/Left switch for testing procedures. See page 22.
	4. Start switch	Refer to Service - Start switch for testing procedures. See page 26.
	5. Brew timer	Refer to Service - Brew timer for testing procedures. See page 16.
	6. Relay	Refer to Service - Relay for testing procedures. See page 23.
	7. Solenoid valve	Refer to Service - Solenoid valve for testing procedures. See page 25.
Automatic refill will not operate after drawing hot water.	1. On/Left switch	(A) The On/Left switch must be in the upper position for the automatic refill to operate. (B) Refer to Service - On/Left switch for testing procedures. See page 22.

TROUBLESHOOTING (cont.)

PROBLEM	PROBABLE CAUSE	REMEDY
Automatic refill will not operate after drawing hot water.(cont.)	2. Liquid level control system	Refer to Service - Liquid Level Control system for testing procedures. See page 20.
	3. Relay	Refer to Service - Relay for testing procedures. See Page 23.
	4. Solenoid valve	Refer to Service - Solenoid valve for testing procedures. See page 25.
Water flows into tank continuously (On/left switch "OFF")	1. Solenoid valve	Refer to Service - Solenoid valve for testing procedures. See page 25.
Water flows into tank continuously (On/left switch "ON")	1. Liquid level control system	Refer to Service - Liquid Level Control system for testing procedures. See page 20.
	2. Relay	Refer to Service - Relay for testing procedures. See page 23.
	3. Brew timer	Refer to Service - Brew timer for testing procedures. See page 14.
Water is not hot.	1. Limit thermostat CAUTION: Do not eliminate or bypass limit thermostat. Use only .replacement part #29329.1000	Refer to Service - Limit Thermostat for testing procedures. See page 19.
	2. Control thermostat	Refer to Service - Control Thermostat for testing procedures. See page 17.
	3. Tank heater	Refer to Service - Tank Heater for testing procedures. See page 27.

TROUBLESHOOTING (cont.)

PROBLEM	PROBABLE CAUSE	REMEDY
Decanter warmer is not hot	1. Warmer switches	(A) The decanter warmer switch must be in the upper position for the warmer to operate. (B) Refer to Service - On/Left or Right switch for testing procedures. See page 22 or 24.
	2. Decanter warmers	Refer to Service - Decanter Warmer for testing procedures. See page 18.
Spitting or unusual steaming from sprayhead	1. Control thermostat	Refer to Service - Control Thermostat for testing procedures. See page 17.
	2. Lime build-up CAUTION: Tank and tank components should be delimed regularly depending on local water conditions. Excessive mineral build-up on stainless steel surfaces can initiate corrosive reactions resulting in serious leaks.	Inspect the tank assembly for excessive lime deposits. Delime as required.
Inconsistent beverage level in decanter	1. Flow control	(A) Direction of flow arrow must be pointing towards the brewer. (B) Remove the control and check for obstructions. Clear or replace.
	2. Improper water pressure	Check the operating water pressure to the brewer. It must be between 20(138) and 90 psi(620 kPa).

TROUBLESHOOTING (cont.)

PROBLEM	PROBABLE CAUSE	REMEDY
Inconsistent beverage level in decanter (cont.)	3. Syphon System	Water should flow freely from the sprayhead for approximately twenty seconds after the brew solenoid has shut off and then stop flowing abruptly. The brewer must be level from side-to-side to syphon properly.
Consistently high or low beverage level in decanter.	1. Brew timer adjustment	Adjust the brew timer as required to achieve the recommended 64 oz. for each brew cycle.
Dripping from sprayhead	1. Syphon System	Water should flow freely from the sprayhead for approximately twenty seconds after the brew solenoid has shut off and then stop flowing abruptly. The brewer must be level from side-to-side to syphon properly.
	2. Solenoid valve	Refer to Service - Solenoid valve for testing procedures. See page 25.
Beverage overflows decanter.	1. Beverage left in decanter	The brew cycle should be started only with an empty decanter under the funnel.
	2. Incorrect decanter size.	Use only 64 oz. decanters.
Weak beverage	1. Type of paper filters	BUNN® paper filters should be used for proper extraction.
	2. Coffee	A sufficient quantity of fine or drip grind coffee should be used for proper extraction.
	3. Sprayhead	Bunn-O-Matic sprayhead #01082.0000 should be used to properly wet the bed of ground coffee in the funnel.

TROUBLESHOOTING (cont.)

PROBLEM	PROBABLE CAUSE	REMEDY
Weak beverage (cont.)	4. Funnel loading	The BUNN® paper filter should be centered in the funnel and the bed of ground coffee leveled by gentle shaking.
	5. Water temperature	Empty a decanter and place it on the left warmer. Insert an empty funnel into the funnel rails. Place the On/left switch in the upper position. Press the Start switch and check the water temperature immediately below the sprayhead with a thermometer. The reading should not be less than 195° F. Adjust the control thermostat slightly clockwise to increase the water temperature.
Brewer is making unusual noises	1. Solenoid valve	The nut on top of the solenoid valve must be tight or it will vibrate during operation.
	2. Plumbing lines	Plumbing lines should not be resting on the counter top.
	3. Water supply	(A) The brewer must be connected to a cold water line. (B) Water pressure to the brewer must not be higher than 90 psi(620 kPa). Install a regulator if necessary to lower the working pressure to approximately 50 psi(345kPa).

SERVICE

This section provides procedures for testing and replacing various major components used in this brewer should service become necessary. Refer to Troubleshooting for assistance in determining the cause of any problem.

COMPONENT ACCESS

WARNING - Unplug the brewer before the removal of any panel or the replacement of any component

The On/Left switch, Start switch, Right switch, solenoid valve, brew timer, liquid level control components, relay, control thermostat, limit thermostat, and tank heater are located in the hood. Access is gained by removing the top lid, attached with two #4-40 slot-head screws.

WARNING - Inspection, testing, and repair of electrical equipment should be performed only by qualified service personnel. The brewer should be unplugged when servicing, except when electrical tests are required and the test procedure specifically states to plug in the brewer.

CONTENTS

Brew Timer	14
Control Thermostat	17
Decanter Warmer(s)	18
Limit Thermostat.....	19
Liquid Level Control System	20
On/Left Warmer Switch.....	22
Relay	23
Right Warmer Switch.....	24
Solenoid Valve	25
Start Switch	26
Tank Heater	27
Wiring Diagram.....	28

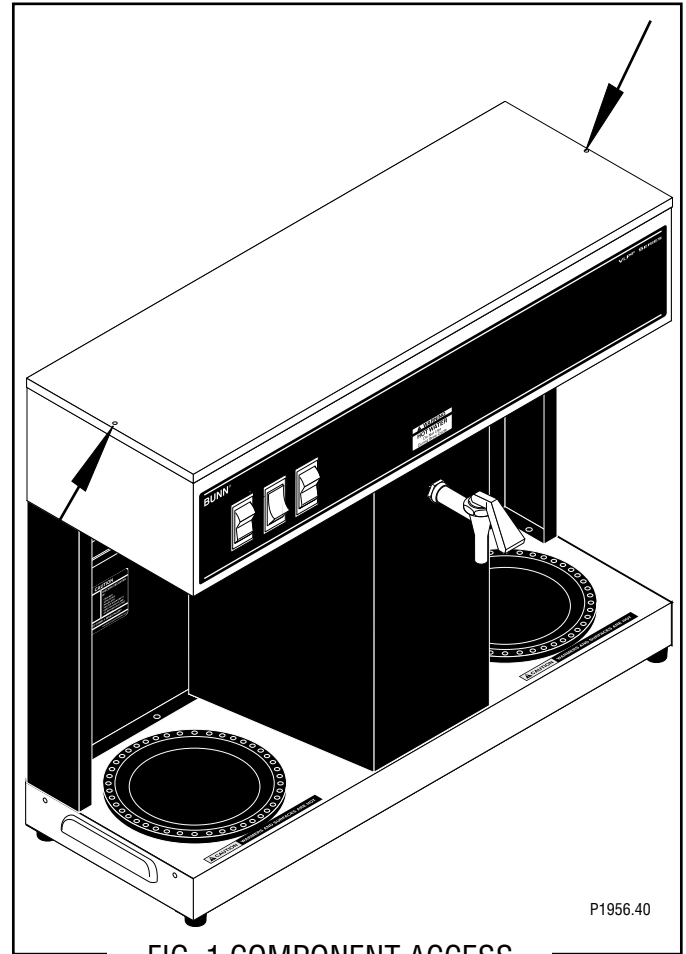

FIG. 1 COMPONENT ACCESS

SERVICE (cont.)

BREW TIMER (early models)

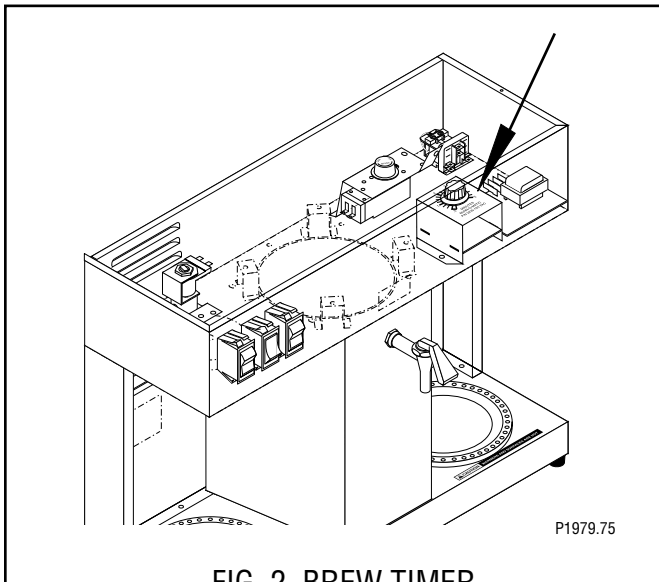

FIG. 2 BREW TIMER

Location:

The brew timer is located in the hood, to the right of the tank.

Test Procedure:

1. Disconnect the brewer from the power source and separate the polarized, three-pin connectors between the timer and brewer wiring harness and rotate the brew timer dial fully counterclockwise.
2. With a voltmeter, check the voltage across sockets 2 & 3 (white and black wires) of the female connector when the On/Left switch is in the upper position. Connect the brewer to the power source. The indication must be 120 volts ac.
3. Disconnect the brewer from the power source.

If voltage is present as described, proceed to #4. If voltage is not present as described, refer to the Wiring Diagram and check the brewing harness.

4. With a voltmeter, check the voltage across sockets 1 & 2 (blue and white wires) of the female connector when the On/Left switch is in the upper position and the Start switch is pressed to the lower position and held. Connect the brewer to the power source. The indication must be 120 volts ac until the Start switch is released.
5. Disconnect the brewer from the power source.

If voltage is present as described, reconnect the polarized, three-pin connectors, and proceed to #6. If voltage is not present as described, refer to the Wiring Diagram and check the brewer wiring harness.

6. Disconnect the in-line connectors on the black and white wires from the timer to the wiring harness.
7. With a voltmeter, check the voltage across the black and white wires when the On/Left switch is in the upper position and the Start switch is pressed to the lower position and released. Connect the brewer to the power source. The indication must be 120 volts ac for approximately 20 seconds and then return to its previous indication.
8. Disconnect the brewer from the power source.

If voltage is present as described, the brew timer is operating properly. Reset the timer dial as required, to obtain the desired brew volume. If voltage is not present as described, replace the brew timer.

Removal and Replacement:

1. Separate all connectors between the brewer wiring harness and the timer.
2. Remove the two #8-32 nuts holding the timer to the inside of the hood.
3. Install the new timer circuit board as described in Late Model Timer section on the following pages.
4. Refer to FIG. 5 when reconnecting the wires.
5. Install the Timer Setting decal provided with the replacement timer kit, on the bottom of the top cover.
6. Adjust the timer as required. Refer to Late Model Timer section on the following pages.

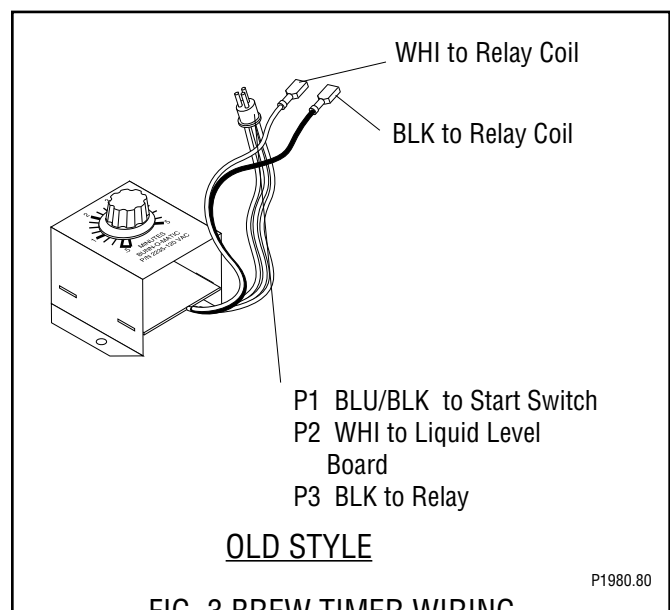

FIG. 3 BREW TIMER WIRING

SERVICE (cont.)
BREW TIMER (cont.)(late models)

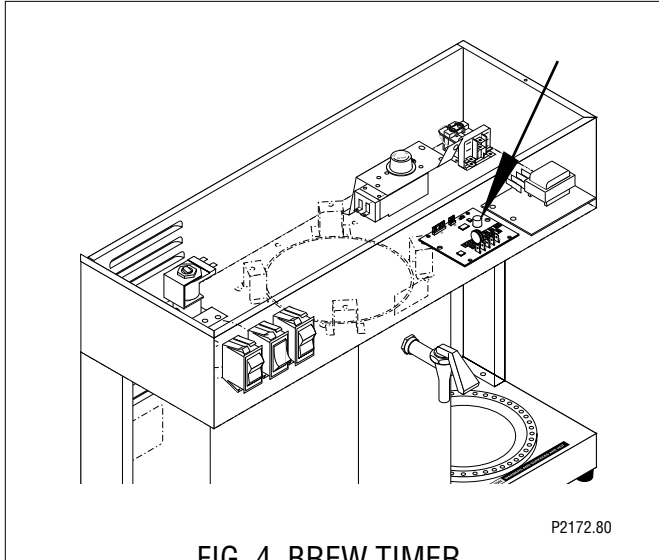

FIG. 4 BREW TIMER

Location:

The brew timer is located in the hood, to the right of the tank.

Test Procedures:

1. Disconnect the brewer from the power source and remove the top cover.
2. With a voltmeter, check the voltage across terminals TL1 and TL2 when the “ON/OFF” switch is in the “ON” position. Connect the brewer to the power source. The indication must be 120 volts ac.
3. Disconnect the brewer from the power source.

If voltage is present as described, proceed to #4.
If voltage is not present as described, refer to the *Wiring Diagram* and check the brewer wiring harness.

4. Disconnect the white/blue wire from terminal TL3 and the blue wire from terminal TL5. Check for continuity across the two wires when the start switch is pressed to the “START” position.

If continuity is present as described, reconnect the wires and proceed to #5.
If continuity is not present as described, refer to the *Wiring Diagram* and check the brewer wiring harness.

5. With a voltmeter, check the voltage across terminals TL1 and TL4 when the “ON/OFF” switch is in the “ON” position. Connect the brewer to the power source. The indication must be 0 volts.

If voltage is as described, proceed to #6.
If voltage is not as described, disconnect the brewer from the power source and replace the timer.

6. With a voltmeter, check the voltage across terminals TL1 and TL4 when the “ON/OFF” switch is in the “ON” position. Connect the brewer to the power source and press the start switch. The indication must be 120 volts ac.

If voltage is present as described, the brew timer is operating properly. Reset the timer as required, to obtain the desired brew volume.

If voltage is not present as described, disconnect the brewer from the power source and replace the timer.

Removal and Replacement:

NOTE: Do not remove or install wires while timer board is installed. Pressure applied to one side may cause damage to the board.

1. Remove the two #8-32 nuts securing circuit board to the hood.
2. Remove circuit board and spacers (as required).
3. Remove all wires from the timer.
4. Attach all wires to the replacement timer board prior to installation to the component mounting bracket. Refer to FIG. 5 when reconnecting the wires.
5. Install new circuit board with spacers (as required) to the hood.
6. Adjust the timer as described below.

Timer Setting:

NOTE: Prior to setting or modifying volumes, check that the brewer is connected to water supply, the tank is properly filled, and a funnel and server are in place.

NOTE: All volume settings must be done with the sprayhead installed.

SERVICE (cont.)

BREW TIMER (cont.)(late models)

1. **Modifying brew volumes.** To modify a brew volume, first check that the SET/LOCK switch is in the “SET” position on the circuit board.

To increase a brew volume, place the ON/OFF switch in the “ON” position, press and hold the START switch until three clicks are heard. Release the switch and press it again one or more times. (Failure to release the switch within two seconds after the third click causes the volume setting to be aborted and previous volume setting will remain in memory) Each time the switch is pressed, two seconds are added to the brew time period. Allow the brew cycle to finish in order to verify that the desired volume has been achieved.

To decrease a brew volume, place the ON/OFF switch in the “ON” position, press and release the START switch once for every two-second interval to be removed from the total brew time period; then immediately press and hold down the START switch until three clicks are heard. Release the switch. (Failure to release the switch within two seconds after the third click causes the volume setting to be aborted and previous volume setting will remain in memory). Allow the brew cycle to finish in order to verify that the desired volume has been achieved.

2. **Setting brew volumes.** To set a brew volume, first check that the SET/LOCK switch is in the “SET” position on the circuit board. Place the ON/OFF switch in the “ON” position, press and hold the START switch until three distinct clicks are heard and then release the switch. (Failure to release the switch within two seconds after the third click causes the volume setting to be aborted and previous volume setting will remain in memory).

View the level of the liquid being dispensed. When the desired level is reached, turn the ON/OFF switch to “OFF”.

NOTE: Several ounces of water will continue to sy-

phon from the tank after turning the switch “OFF”. The brewer remembers this volume and will continue to brew batches of this size until the volume setting procedure is repeated.

NOTE: When brewing coffee, volume will decrease due to absorption by the coffee grounds.

3. **Setting programming disable feature.** If it becomes necessary to prevent anyone from changing brew time once programmed, you can set the SET/LOCK switch to the “LOCK” position. This will prevent any further programming until switch is once again put into the “SET” position.

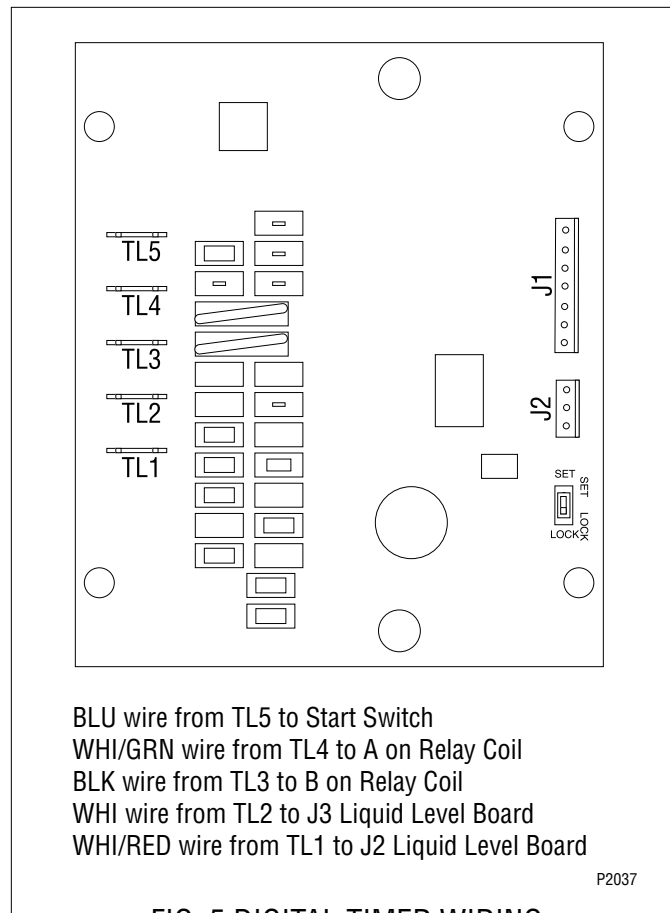

FIG. 5 DIGITAL TIMER WIRING

SERVICE (cont.)
CONTROL THERMOSTAT

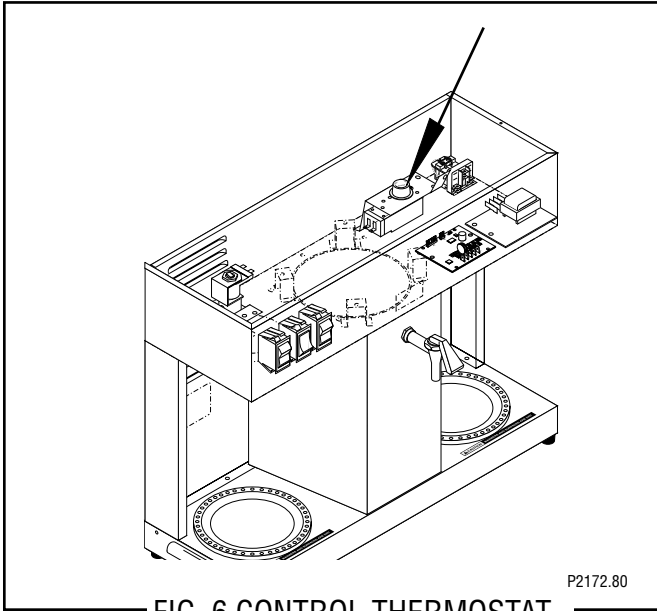

FIG. 6 CONTROL THERMOSTAT

Location:

The control thermostat is located on the rear of the hood to the right of the tank.

Test Procedure:

1. Disconnect the brewer from the power source and remove the black wire from the control thermostat.
2. With a voltmeter, check the voltage across the black wire removed from the control thermostat and the white wire on the tank heater terminal. Connect the brewer to the power source. The indication must be 120 volts ac.
3. Disconnect the brewer from the power source.

If voltage is present as described, reconnect the black wire and proceed to #4.

If voltage is not present as described, refer to the Wiring Diagram and check the brewer wiring harness.

4. Remove the blue wire from the control thermostat.
5. With a voltmeter, check the voltage across the exposed terminal of the control thermostat and the white wire on the tank heater terminal when the control thermostat is turned "ON" (fully clockwise). Connect the brewer to the power source. The indication must be 120 volts ac. Voltage must not be indicated across these terminals when the thermostat is turned "OFF" (fully counterclockwise).

6. Disconnect the brewer from the power source.

If voltage is present as described, reconnect the blue wire, the control thermostat is operating properly. If voltage is not present as described, replace the control thermostat.

Removal and Replacement

1. Remove both wires from the control thermostat terminals.
2. Remove the thermostat bulb by firmly pulling up on the capillary tube at the tank lid. This will disengage the grommet from the tank lid.
3. Remove the two #8-32 screws holding the control thermostat to the brewer housing.
4. Slide the grommet to the red mark on the capillary tube.
5. Insert the bulb through the hole in the tank lid and press the grommet firmly and evenly so the groove in the grommet fits into the tank lid.
6. Carefully bend the capillary tube so the tube and bulb inside the tank are in a vertical position.

NOTE - Make sure the capillary tube is away from any electrical termination and is not kinked.

7. Fasten the new control thermostat to the brewer housing.
8. Refer to FIG. 7 when reconnecting the wires.
9. Readjust the control thermostat dial as required.

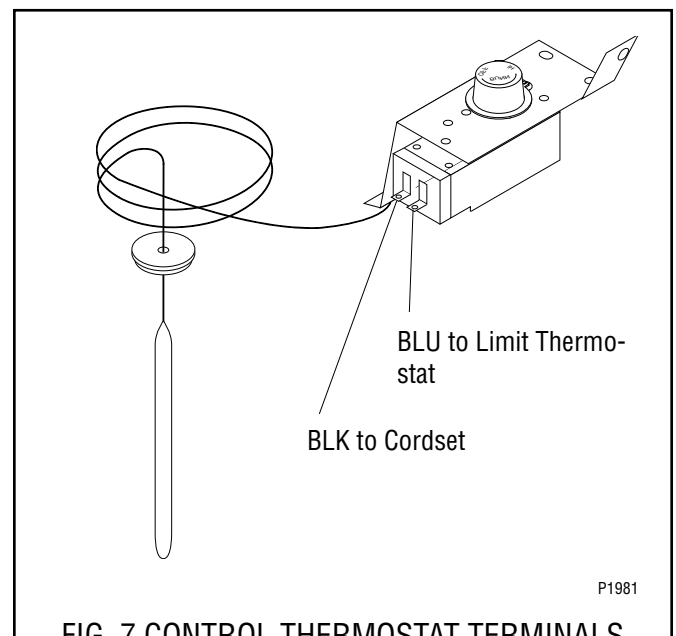
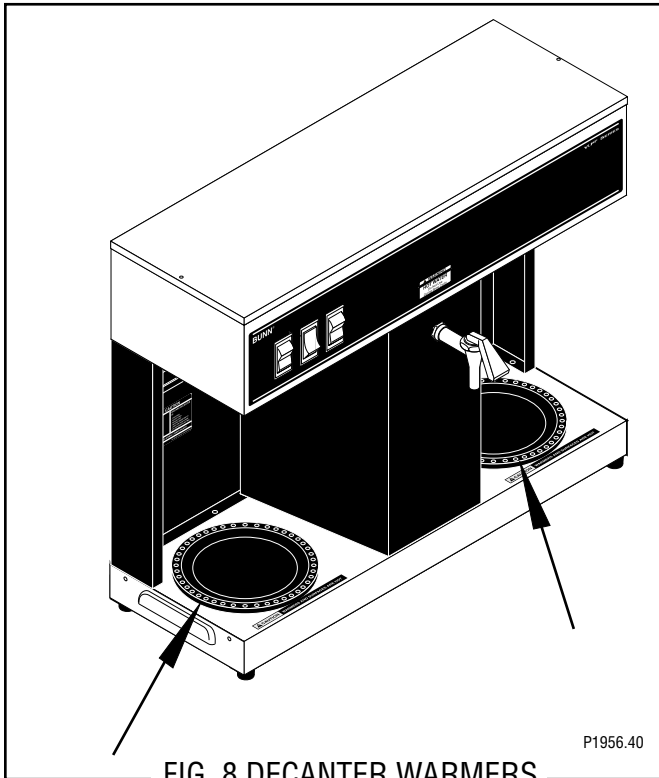

FIG. 7 CONTROL THERMOSTAT TERMINALS

SERVICE (cont.)
DECANTER WARMERS



Location:

___The decanter warmers are located in the base of the brewer.

Test Procedure:

1. Disconnect the brewer from the power source and remove the three #4-40 screws attaching the suspect warmer.
2. Bring the warmer assembly out the top of the base.
3. Disconnect both wires from the warmer. Make sure that the wire ends do not touch any metal surface of the brewer.
4. With a voltmeter, check the voltage across the two wires removed from the warmer when the appropriate warmer switch (on/left or right) is in the upper position. The voltage must be 120 volts ac.

5. Connect the crewer to the power source.

If voltage is present as described, proceed to #6. If voltage is not present as described, refer to the Wiring Diagram and check the brewer wiring harness.

6. Disconnect the brewer from the power source.
7. Check for continuity across the two terminals on the warmer.

If continuity is present as described, reconnect the wires to the terminals, the warmer is operating properly.

If continuity is not present as described, replace the warmer.

Removal and Replacement

1. Remove the three #4-40 slotted-head screws holding the warmer to the brewer base.
2. Bring the warmer out the top of the base.
3. Disconnect both wires from the warmer.
4. Refer to FIG. 9 when reconnecting the wires and orienting the warmers.
5. Place the warmer into the base and securely attach it using the three #4-40 screws.

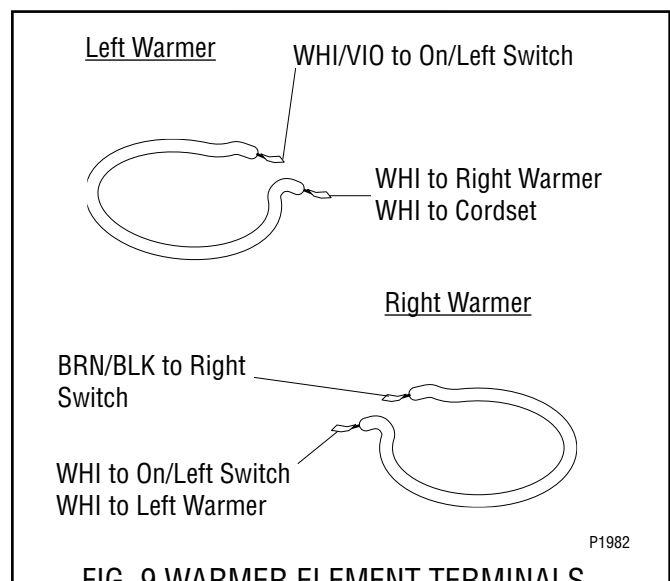

SERVICE (cont.)

LIMIT THERMOSTAT

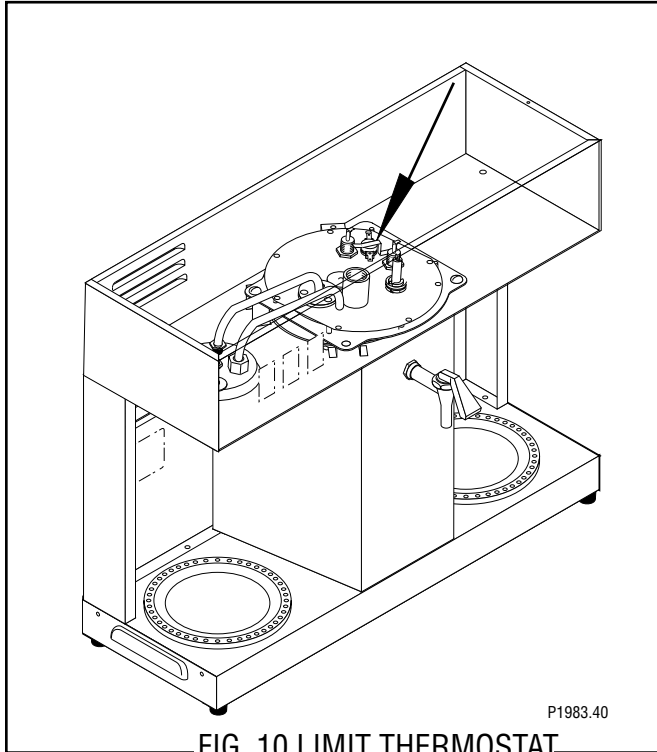

FIG. 10 LIMIT THERMOSTAT

Location:

The limit thermostat is located on the tank lid between the tank heater terminals.

Test Procedure:

1. Disconnect the brewer from the power source and remove the blue wire from the limit thermostat.
2. With a voltmeter, check the voltage across the blue wire removed from the limit thermostat and the white wire on the tank heater terminal when the control thermostat is turned "ON" (fully clockwise). Connect the brewer to the power source. The indication must be 120 volts ac.
3. Disconnect the brewer from the power source.

If voltage is present as described, reconnect the blue wire and proceed to #4.

If voltage is not present as described, refer to the Wiring Diagram and check the brewer wiring harness.

4. Remove the black wire from the limit thermostat.
5. With a voltmeter, check for voltage across the exposed terminal of the limit thermostat and the white wire on the tank heater terminal when the control thermostat is turned "ON" (full clockwise). Connect the brewer to the power source. The indication must be 120 volts ac.
6. Disconnect the brewer from the power source.

If voltage is present as described, reconnect the black wire, the limit thermostat is operating properly.

If voltage is not present as described, replace the limit thermostat.

Removal and Replacement:

1. Remove both wires from the limit thermostat terminals.
2. Carefully slide the limit thermostat out from under the retaining clip.
3. Carefully slide the new limit thermostat into the retaining clip.
4. Refer to FIG. 11 when reconnecting the wires.

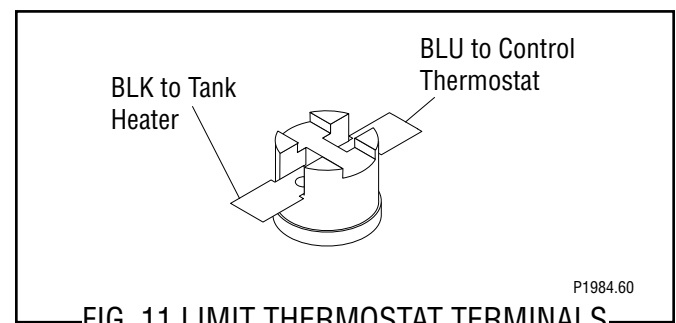

FIG. 11 LIMIT THERMOSTAT TERMINALS

SERVICE (cont.)

LIQUID LEVEL CONTROL SYSTEM

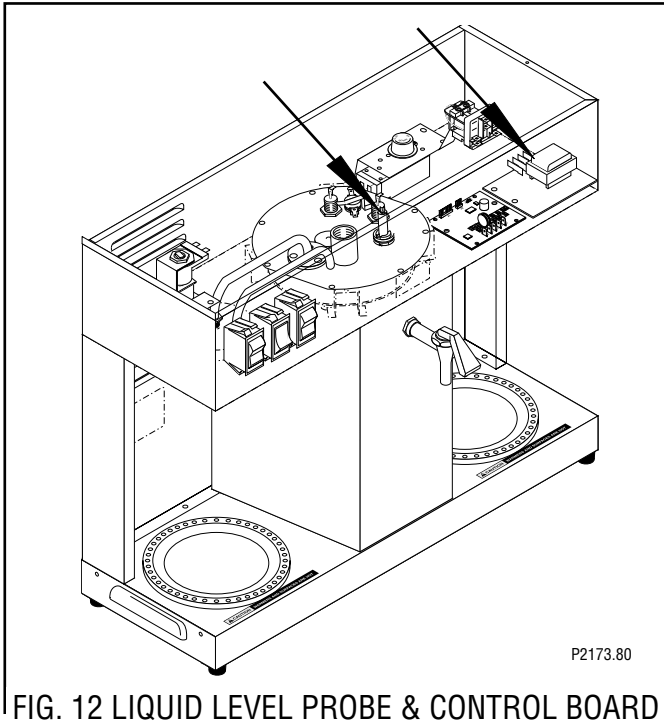

FIG. 12 LIQUID LEVEL PROBE & CONTROL BOARD

Location:

The liquid level control system is composed of the circuit board in the right front corner of the hood and the probe in the tank lid.

Test Procedure:

1. Disconnect the brewer from the power source and remove the wires from terminals 1 & 4 of the circuit board.
2. With a voltmeter, check the voltage across terminals 2 & 3 when the On/Left switch is in the upper position. Connect the brewer to the power source. The indication must be 120 volts ac.
3. Disconnect the brewer from the power source.

If voltage is present as described, proceed to #4.
If voltage is not present as described, refer to the Wiring Diagram and check the brewer wiring harness.

4. Reconnect the brown/white wire to terminal 1.
5. Carefully connect a piece of insulated jumper wire to terminal 4. Keep the other end of this wire away

from any metal surface of the brewer.

6. With a voltmeter, check the voltage across terminals 1 & 3 when the On/Left switch is in the upper position. Connect the brewer to the power source. The indication must be 120 volts ac after a delay of approximately 5 seconds.
7. Touch the end of the jumper wire to the brewer housing. The indication must be zero.
8. Move the jumper wire away from the brewer housing. The indication must again be 120 volts ac after a delay of approximately 5 seconds.
9. Disconnect the brewer from the power source and remove the jumper wire from terminal 4.

If voltage is present as described, the liquid level control board is operating properly, proceed to #10.
If voltage is not present as described, replace the liquid level control board.

10. Reconnect the pink wire to terminal 4.
11. Gently pull the probe out of the tank lid and inspect for corrosion. Replace it if necessary.
12. Place the probe so that neither end is in contact with any metal surface of the brewer.
13. With a voltmeter, check the voltage across terminals 1 & 3 when the On/Left switch is in the upper position. Connect the brewer to the power source. The indication must be 120 volts ac after a delay of approximately 5 seconds.
14. Touch the probe's flat end to the brewer housing. The indication must be zero.
15. Move the probe's flat end away from the brewer housing. The indication should again be 120 volts ac after a delay of approximately 5 seconds.
16. Disconnect the brewer from the power source.

If voltage is present as described, reinstall the probe, the liquid level control system is operating properly.
If voltage is not present as described, check the pink probe wire and/or replace the probe.

SERVICE (cont.)

LIQUID LEVEL CONTROL SYSTEM (cont.)

Removal and Replacement:

1. Remove all wires from the liquid level control board terminals.
2. Remove the two #8-32 slotted-head screws holding the circuit board to the brewer hood.
3. Install the new circuit board to the hood, making sure that the two lock-washers are in place below the board and above the spacers.
4. Refer to FIG. 13 when reconnecting the wires.

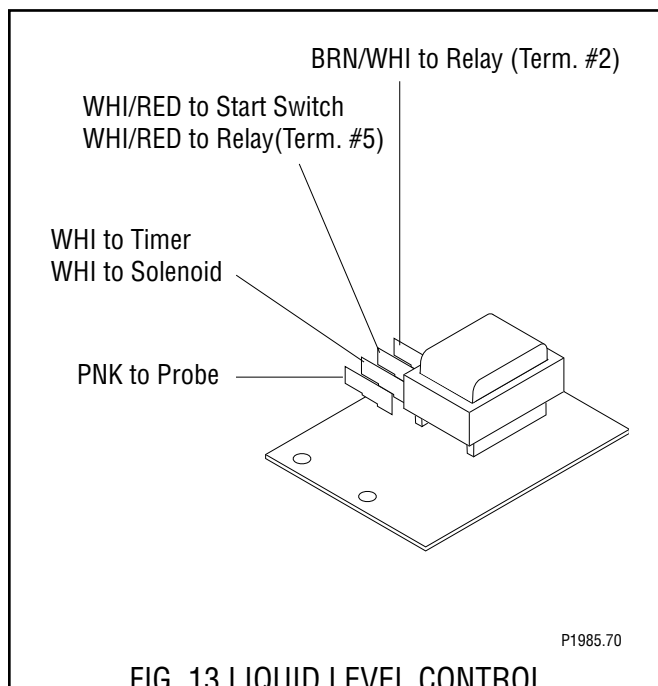
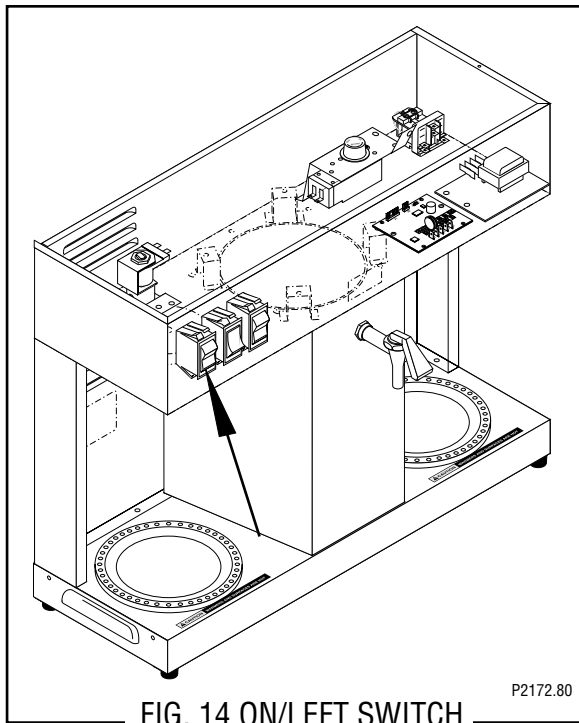

FIG. 13 LIQUID LEVEL CONTROL
BOARD TERMINALS

SERVICE (cont.)

ON/LEFT SWITCH



Location:

The On/Left switch is located in the front of the hood, above and to the left of the brew funnel.

Test Procedure:

1. Disconnect the brewer from the power source and remove the wires from all three terminals of the On/Left switch.
2. With a voltmeter, check the voltage across the black and white wires. Connect the brewer to the power source. The indication must be 120 volts ac.
3. Disconnect the brewer from the power source.

If voltage is present as described, proceed to #4.

If voltage is not present as described, refer to the Wiring Diagram and check the brewer wiring harness.

4. Check for continuity across the two terminals on the left side of the switch when it is in the upper position. Continuity must not be present across these terminals in the lower position.

If continuity is present as described, reconnect the wires, the switch is operating properly.

If continuity is not present as described, replace the switch.

Removal and Replacement:

1. Remove all wires from the switch terminals.
2. Compress the clips inside the hood and gently push the switch through the opening.
3. Push the new switch into the opening and spread the clips to hold the switch captive in the panel.
4. Refer to FIG. 15 when reconnecting the wires.

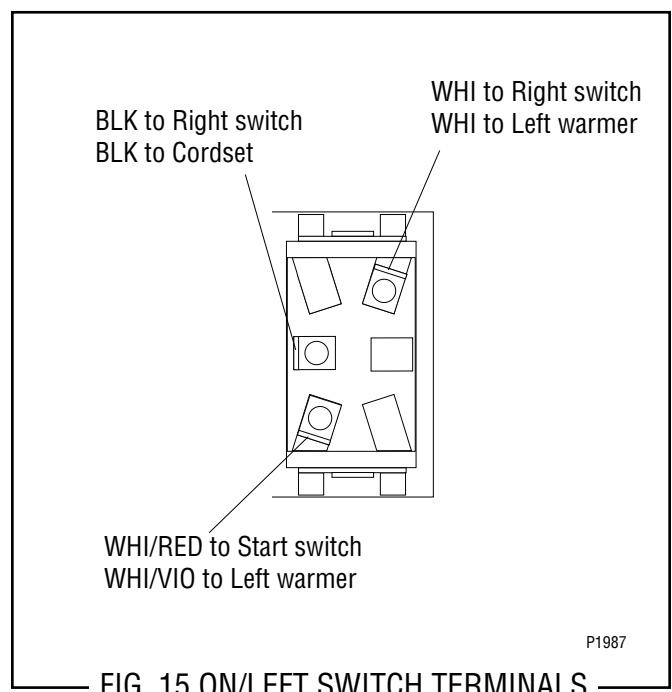

SERVICE (cont.)

RELAY

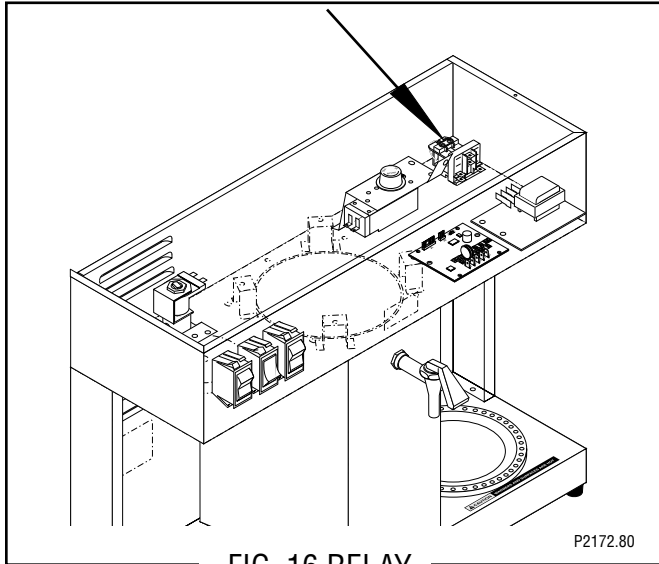

FIG. 16 RELAY

Location:

___The relay is located in the right rear corner of the hood.

Test Procedures

1. Disconnect the brewer from the power source.
2. With a voltmeter, check the voltage across terminals A & B in the lower corners of the relay when the On/Left switch is in the upper position and the Start switch is pressed to the lower position and released. Connect the brewer to the power source. The indication must be 120 volts ac for the approximate setting of the brew timer and then return to zero.
3. Disconnect the brewer from the power source.

If voltage is present as described, proceed to #4.

If voltage is not present as described, refer to the Wiring Diagram and check the brewer wiring harness.

4. Remove the black and white wires from terminals A & B.
5. Check for continuity across terminals A & B of the relay.

If continuity is present as described, reconnect the black and white wires and proceed to #6.

If continuity is not present as described, replace the relay.

6. Remove the brown/white, white/red, and white/blue wires from terminals 2, 5 & 7 of the relay.

7. Check for continuity across terminals 2 & 7 when the On/Left switch is in the upper position only until the Start switch is pressed to the lower position and released. Connect the brewer to the power source. Continuity must return across these terminals after the approximate setting of the brew timer.
8. Disconnect the brewer from the power source.
9. Check for continuity across terminals 5 & 7 when the On/Left switch is in the upper position and the Start switch is pressed to the lower position and released. Connect the brewer to the power source. Continuity must be present across these terminals for the approximate setting of the brew timer.
10. Unplug the brewer.

If continuity is present as described, reconnect the wires, the relay is operating properly.

If continuity is not present as described, replace the relay.

Removal and Replacement:

1. Remove all wires from the relay terminals.
2. Remove the two #8-32 nuts holding the relay mounting bracket to the hood.
3. Remove the relay from the mounting bracket.
4. Securely install the new relay to the mounting bracket.
5. Install the relay mounting bracket to the hood.
6. Refer to FIG. 17 when reconnecting the wires.

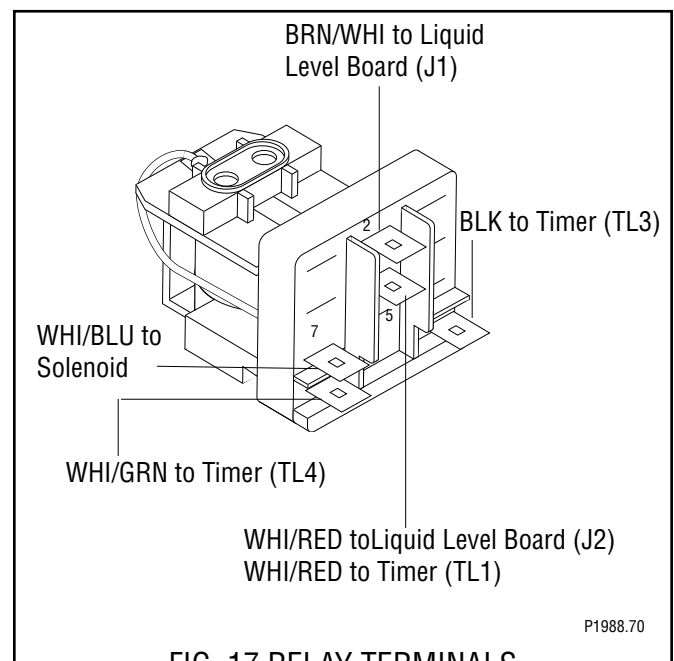

FIG. 17 RELAY TERMINALS

SERVICE (cont.)

RIGHT SWITCH

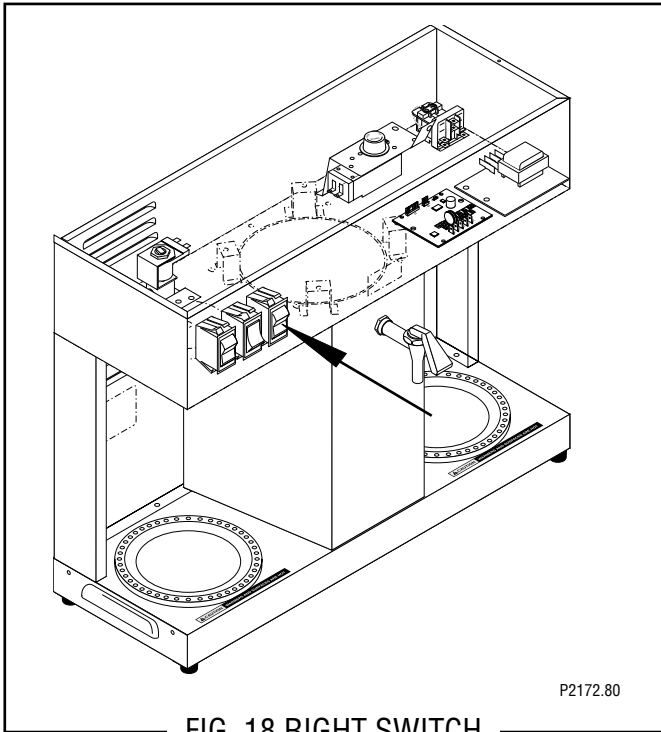

FIG. 18 RIGHT SWITCH

Location:

The Right switch is located in the front of the hood, above and to the right of the brew funnel.

Test Procedure:

1. Disconnect the brewer from the power source and remove the wires from all three terminals of the Right switch.
2. With a voltmeter, check the voltage across the black and white wires. Connect the brewer to the power source. The indication must be 120 volts ac.
3. Disconnect the brewer from the power source.

If voltage is present as described, proceed to #4.
If voltage is not present as described, refer to the Wiring Diagram and check the brewer wiring harness.

4. Check for continuity across the two terminals on the left side of the switch when it is in the upper position. Continuity must not be present across these terminals in the lower position.

If continuity is present as describe, reconnect the wires, the switch is operating properly.
If continuity is not present as described, replace the switch.

Removal and Replacement:

1. Remove all wires from the switch terminals.
2. Compress the clips inside the hood and gently push the switch through the opening.
3. Push the new switch into the opening and spread the clips to hold the switch captive in the panel.
4. Refer to FIG. 19 when reconnecting the wires.

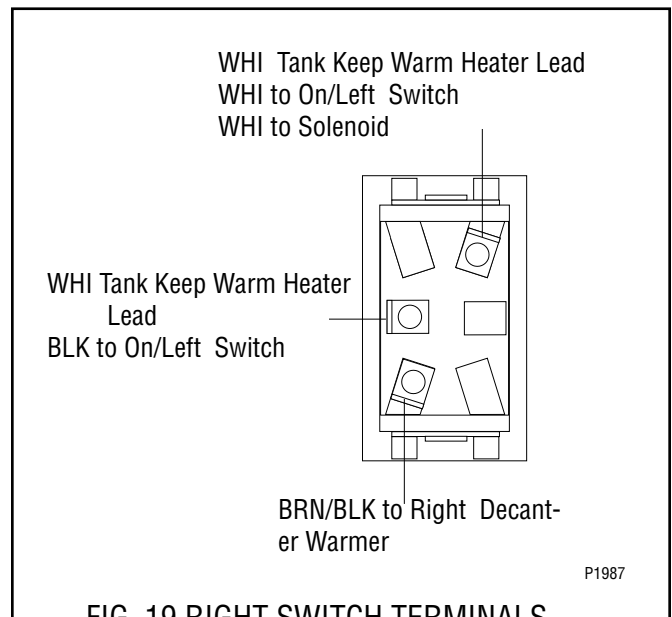

FIG. 19 RIGHT SWITCH TERMINALS

SERVICE (cont.)

SOLENOID VALVE

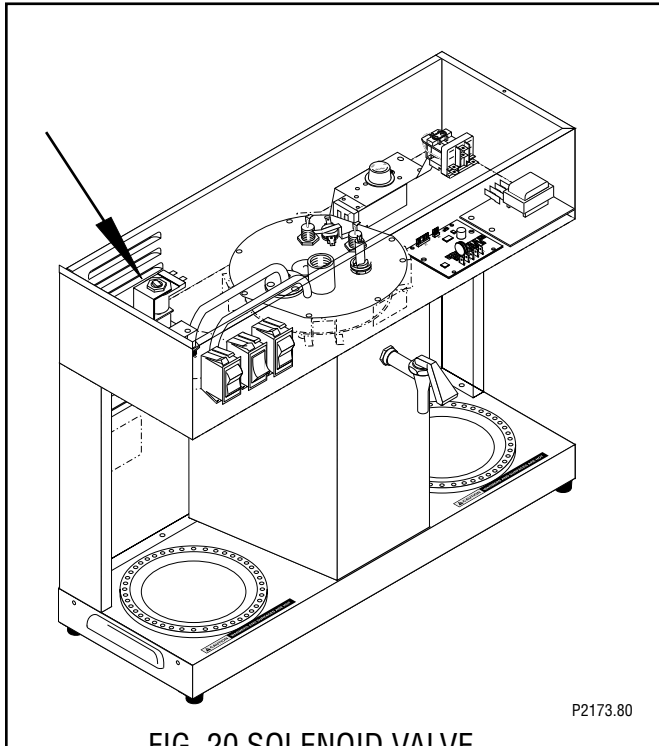

FIG. 20 SOLENOID VALVE

Location:

The solenoid valve is located in the left rear corner of the hood.

Test Procedures:

1. Disconnect the brewer from the power source and remove both wires from the solenoid valve coil terminals.
2. With a voltmeter, check the voltage across the white and white/blue wires when the On/Left switch is in the upper position and the Start switch is pressed to the lower position and released. Connect the brewer to the power source. The indication must be 120 volts ac for the approximate setting on the brew timer dial and then return to zero.
3. Disconnect the brewer from the power source.

If voltage is present as described, proceed to #4.
If voltage is not present as described, refer to the Wiring Diagram and check the brewer wiring harness.

4. Check for continuity across the solenoid valve coil.

If continuity is present as described, reconnect the white and white/blue wires and proceed to #5.
If continuity is not present as described, replace the solenoid valve.

5. Check the solenoid valve for coil action. Connect the brewer to the power source, place the On/Left switch in the upper position, press and release the Start switch. Listen carefully in the vicinity of the solenoid valve for a “clicking” sound as the coil magnet attracts and after the approximate setting on the brew timer dial, repels the plunger.
6. Disconnect the brewer from the power source.

If the sound is heard as described and water will not pass through the solenoid valve, there may be a blockage in the water line before or after the solenoid valve or, the solenoid valve may require inspection for wear, and removal of waterborne particles.

If the sound is not heard as described, replace the solenoid valve.

Removal and Replacement:

1. Remove all wires from the solenoid valve coil.
2. Turn off the water supply to the brewer.
3. Disconnect the water lines to and from the solenoid valve.
4. Remove the two #8-32 nuts holding the solenoid valve mounting bracket to the hood.
5. Lift out the solenoid valve.
6. Remove the solenoid valve from the mounting bracket.
7. Securely install the new solenoid valve to the mounting bracket.
8. Attach the mounting bracket to the hood.
9. Securely fasten the water lines to and from the solenoid valve.
10. Refer to FIG. 21 when reconnecting the wires.

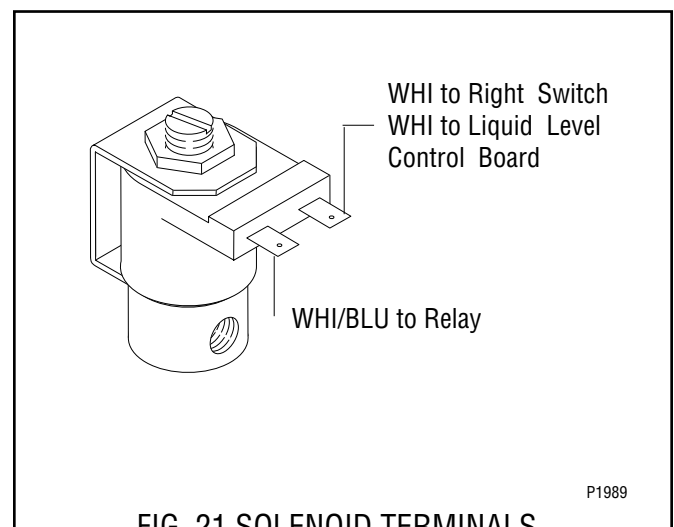

FIG. 21 SOLENOID TERMINALS

SERVICE (cont.)

START SWITCH

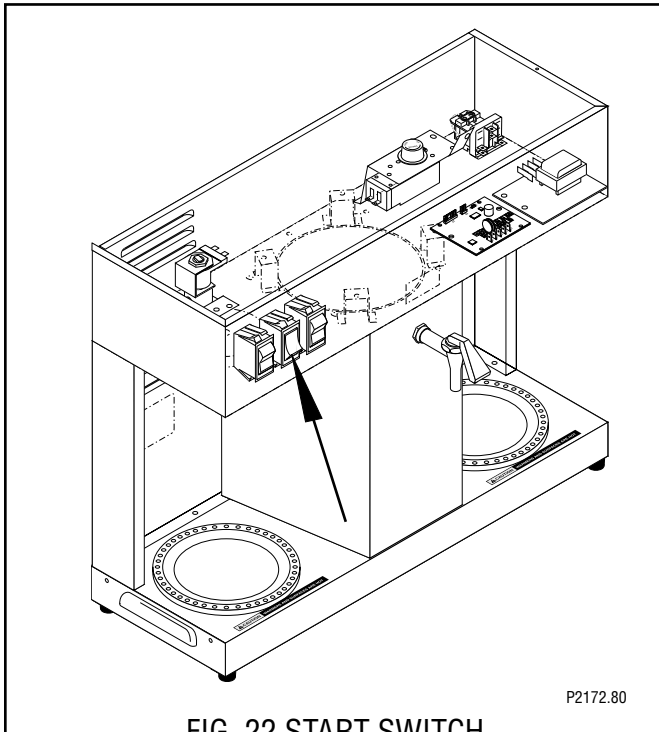

FIG. 22 START SWITCH

Location:

The Start switch is located in front of the hood, centered above the brew funnel.

Test Procedure:

1. Disconnect the brewer from the power source and remove the wires from both terminals of the Start switch.
2. Check for continuity across the two terminals on the switch when it is held in the lower position. Continuity must not be present across these terminals in the upper position.

If continuity is present as described, reconnect the wires, the switch is operating properly. (It does not matter which terminals the wires are installed on). If continuity is not present as described, replace the switch.

Removal and Replacement:

1. Remove all wires from the switch terminals.
2. Compress the clips inside the hood and gently push the switch through the opening.
3. Push the new switch into the opening and spread the clips to hold the switch captive in the hood.
4. Refer to the FIG 23. When reconnecting the wires.

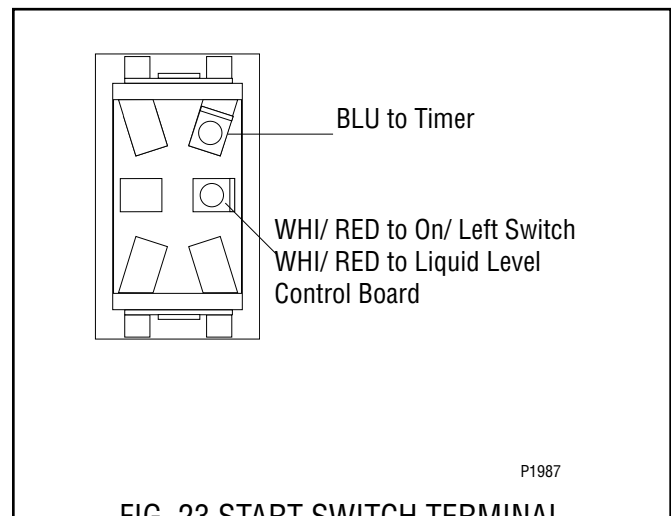

FIG. 23 START SWITCH TERMINAL

SERVICE (cont.)

TANK HEATER

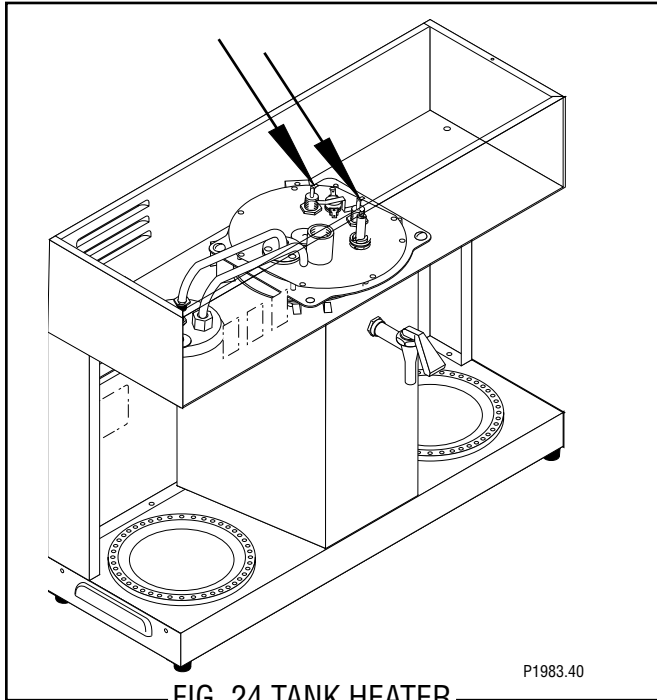

FIG. 24 TANK HEATER

Location:

The tank heater is located on the tank lid.

Test Procedure:

1. Disconnect the brewer from the power source and remove both wires from the tank heater.
2. With a voltmeter, check the voltage across the black and white wires removed from the tank heater when the control thermostat is turned "ON" (fully clockwise). Connect the brewer to the power source. The indication must be 120 volts ac.
3. Disconnect the brewer from the power source.

If voltage is present as described, proceed to #4.

If voltage is not present as described, refer to the Wiring Diagram and check the brewer wiring harness.

4. Check for continuity across the terminals of the tank heater.

If continuity is present as described, reconnect the wires, the tank heater is operating properly.

If continuity is not present as described, replace the tank heater.

NOTE - If the tank heater remains unable to heat, remove and inspect the heater for cracks in the sheath.

Removal and Replacement:

1. Remove the white wire from the tank heater terminal and the blue wire from the limit thermostat terminals.
2. Gently pull the liquid level probe and thermostat tube with grommet out of the tank lid.
3. Disconnect the 1/4" flare fitting on the tank lid inlet fitting.
4. Remove the sprayhead and sprayhead nut from the panel on the bottom of the hood.
5. Disconnect the airvent tube from the fitting above the sprayhead panel.
6. Loosen the eight #8-32 nuts on the tank lid and remove the tank lid.
7. Remove the two nuts from the tank heater fittings.
8. Remove the tank heater.
9. Install the new tank heater with new sealing washers on the underside of the tank lid.
10. Securely tighten the nuts to be certain of a water-tight seal.
11. Reinstall tank lid and secure with eight #8-32 nuts.
12. Reinstall the sprayhead tube nut and sprayhead.
13. Reinstall the liquid level probe and thermostat into the tank lid.
14. Securely fasten the 1/4" flare fitting to the tank lid inlet fitting.
15. Refer to FIG. 25 when reconnecting the wires.

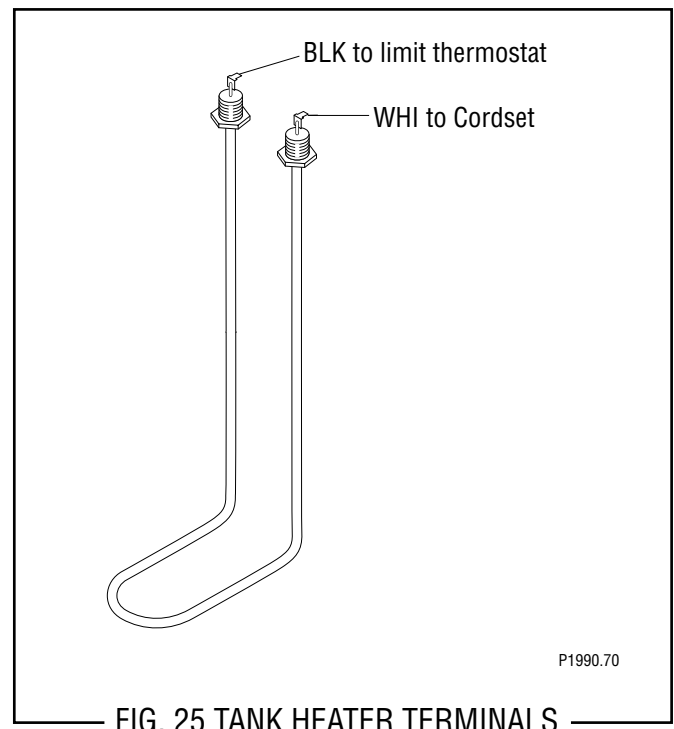

FIG. 25 TANK HEATER TERMINALS

SCHEMATIC WIRING DIAGRAM VLPF

