

BUNN®

VPR-VPS SERIES



SERVICE & REPAIR MANUAL

BUNN-O-MATIC CORPORATION

POST OFFICE BOX 3227

SPRINGFIELD, ILLINOIS 62708-3227

PHONE: (217) 529-6601 FAX: (217) 529-6644

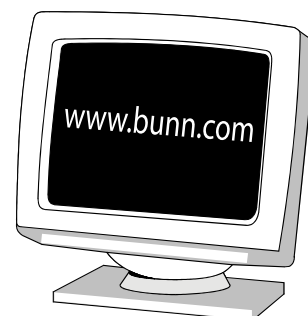

BUNN-O-MATIC COMMERCIAL PRODUCT WARRANTY

Bunn-O-Matic Corp. ("BUNN") warrants equipment manufactured by it as follows:

- 1) All equipment other than as specified below: 2 years parts and 1 year labor.
- 2) Electronic circuit and/or control boards: parts and labor for 3 years.
- 3) Compressors on refrigeration equipment: 5 years parts and 1 year labor.
- 4) Grinding burrs on coffee grinding equipment to grind coffee to meet original factory screen sieve analysis: parts and labor for 3 years or 30,000 pounds of coffee, whichever comes first.

These warranty periods run from the date of installation BUNN warrants that the equipment manufactured by it will be commercially free of defects in material and workmanship existing at the time of manufacture and appearing within the applicable warranty period. This warranty does not apply to any equipment, component or part that was not manufactured by BUNN or that, in BUNN's judgment, has been affected by misuse, neglect, alteration, improper installation or operation, improper maintenance or repair, damage or casualty. This warranty is conditioned on the Buyer 1) giving BUNN prompt notice of any claim to be made under this warranty by telephone at (217) 529-6601 or by writing to Post Office Box 3227, Springfield, Illinois 62708-3227; 2) if requested by BUNN, shipping the defective equipment prepaid to an authorized BUNN service location; and 3) receiving prior authorization from BUNN that the defective equipment is under warranty.

THE FOREGOING WARRANTY IS EXCLUSIVE AND IS IN LIEU OF ANY OTHER WARRANTY, WRITTEN OR ORAL, EXPRESS OR IMPLIED, INCLUDING, BUT NOT LIMITED TO, ANY IMPLIED WARRANTY OF EITHER MERCHANTABILITY OR FITNESS FOR A PARTICULAR PURPOSE. The agents, dealers or employees of BUNN are not authorized to make modifications to this warranty or to make additional warranties that are binding on BUNN. Accordingly, statements by such individuals, whether oral or written, do not constitute warranties and should not be relied upon.

If BUNN determines in its sole discretion that the equipment does not conform to the warranty, BUNN, at its exclusive option while the equipment is under warranty, shall either 1) provide at no charge replacement parts and/or labor (during the applicable parts and labor warranty periods specified above) to repair the defective components, provided that this repair is done by a BUNN Authorized Service Representative; or 2) shall replace the equipment or refund the purchase price for the equipment.

THE BUYER'S REMEDY AGAINST BUNN FOR THE BREACH OF ANY OBLIGATION ARISING OUT OF THE SALE OF THIS EQUIPMENT, WHETHER DERIVED FROM WARRANTY OR OTHERWISE, SHALL BE LIMITED, AT BUNN'S SOLE OPTION AS SPECIFIED HEREIN, TO REPAIR, REPLACEMENT OR REFUND.

In no event shall BUNN be liable for any other damage or loss, including, but not limited to, lost profits, lost sales, loss of use of equipment, claims of Buyer's customers, cost of capital, cost of down time, cost of substitute equipment, facilities or services, or any other special, incidental or consequential damages.

BrewWISE, BrewLOGIC, BrewWIZARD, BUNN Gourmet Ice, BUNN Pour-O-Matic, BUNN, Bunn-OMatic, Bunn-O-Matic, BUNNlink, BUNNserve, BUNN Espresso, DBC, Dr. Brew, Dual, EasyClear, EasyGard, Easy Pour, FlavorGard, Gourmet Ice, Gourmet Juice, High Intensity, IMIX, Infusion Series, Quality Beverage Equipment Worldwide, The Mark of Quality in Beverage Equipment Worldwide, My Café, PowerLogic, Safety-Fresh, Scale-Pro, Single, Smart Funnel, Smart Hopper, SmartWAVE, Soft Heat, SplashGard, System III, ThermoFresh, 392, AutoPOD, AXIOM, Beverage Profit Calculator, Beverage Bar Creator, BrewMETER, BUNNSERVE, BUNNsource, Coffee At Its Best, Cool Froth, Digital Brewer Control, Intellisteam, Nothing Brews Like a BUNN, Pouring Profits, Pulse Wave, Signature Series, Silver Series, Smart Heat, Tea At Its Best, The Horizontal Red Line, Titan, Ultra, are either trademarks or registered trademarks of Bunn-O-Matic Corporation.

CONTENTS

- Warranty 2
- Contents..... 3
- Troubleshooting 4
- Component Access 7
- Control Thermostat 8
- Limit Thermostat (VPR - VPS) 10
- ON/OFF Switch (Warmers)..... 11
- Tank Heater 12
- Thermal Cut-Off (VPRA - VPSA) 13
- Warmer Elements..... 14
- Wiring Diagrams 15

TROUBLESHOOTING

A troubleshooting guide is provided to suggest probable causes and remedies for the most likely problems encountered. If the problem remains after exhausting the troubleshooting steps, contact the Bunn-O-Matic Technical Service Department.

- Inspection, testing, and repair of electrical equipment should be performed only by qualified service personnel.
- This brewer is heated at all times. Keep away from combustibles.

- WARNING** –
- Exercise extreme caution when servicing electrical equipment.
 - Unplug the brewer when servicing, except when electrical tests are specified.
 - Follow recommended service procedures
 - Replace all protective shields or safety notices

PROBLEM	PROBABLE CAUSE	REMEDY
Water is not hot	1. Limit Thermostat or Thermal Cut-Off CAUTION - Do not eliminate or bypass limit thermostat/thermal cut-off. Use only BOM replacement part.	Refer to <i>Service</i> - Limit Thermostat or Thermal Cut-Off for testing procedures. See page 10 or 13
	2. Control Thermostat	Refer to <i>Service</i> - Control Thermostat for testing procedures. See page 9
	3. Tank Heater	Refer to <i>Service</i> - Tank Heater for testing procedures. See page 12
Spitting or excessive steaming	1. Lime Build-up CAUTION - Tank and tank components should be delimed regularly depending on local water conditions. Excessive mineral build-up on stainless steel surfaces can initiate corrosive reactions resulting in serious leaks.	Inspect the tank assembly for excessive lime deposits. Delime as required.
	2. Control Thermostat	Refer to <i>Service</i> - Control Thermostat for testing procedures. Inspect the tank assembly for excessive lime deposits. Delime as required.

TROUBLESHOOTING (cont.)

PROBLEM

PROBABLE CAUSE

REMEDY

Dripping from sprayhead

1. Lime Build-up
CAUTION - Tank and tank components should be delimed regularly depending on local water conditions. Excessive mineral build-up on stainless steel surfaces can initiate corrosive reactions resulting in serious leaks.

Excessive lime deposits. Delime as required.

Beverage overflows dispenser

1. Dispenser

The dispenser must be completely empty before starting a brew cycle.

Weak beverage

1. Filter Type

BUNN® paper filters must be used for proper extraction.

2. Coffee Grind

A fine or drip grind must be used for proper extraction.

3. Sprayhead

A six-hole stainless steel sprayhead must be used for proper extraction.

4. Funnel Loading

The BUNN® paper filter must be centered in the funnel and the bed of grounds leveled by gentle shaking.

5. Water Temperature

Place an empty funnel on an empty dispenser beneath the sprayhead. Pour-in a pitcher of tap water and check the water temperature immediately below the sprayhead with a thermometer. The reading should not be less than 195°F. Adjust the control thermostat to increase the water temperature. Replace if necessary.

TROUBLESHOOTING (cont.)

PROBLEM	PROBABLE CAUSE	REMEDY
Dry coffee grounds remain in the funnel	1. Funnel Loading	The BUNN® paper filter must be centered in the funnel and the bed of grounds leveled by gently shaking.
	2. Sprayhead plugged	Clean/verify that sprayhead holes are not plugged.
Brewer is making unusual noises	1. Tank Heater	Clean lime off the tank heater.
Cool beverage serving temperature	1. ON/OFF Warmer Switch	Refer to <i>Service</i> - ON/OFF Warmer Switch for testing procedures.
	2. Warmer Element(s)	Refer to <i>Service</i> - Warmer Element(s) for testing procedures.

SERVICE

This section provides procedures for testing and replacing various major components used in this brewer should service become necessary. Refer to *Troubleshooting* for assistance in determining the cause of any problem.

WARNING - Inspection, testing, and repair of electrical equipment should be performed only by qualified service personnel. The brewer should be disconnected from the power source when servicing, except when electrical tests are required and the test procedure specifically states to plug-in the brewer.

COMPONENT ACCESS

WARNING - Disconnect the brewer from the power source before the removal of any panel or the replacement of any component.

All components are accessible by the removal of the top cover, fill basin and warmer assemblies.

The top cover is attached with two #4-40 screws.

The tank inlet fitting secures the fill basin to the tank lid. Basin wrench 01060.0000 shown.

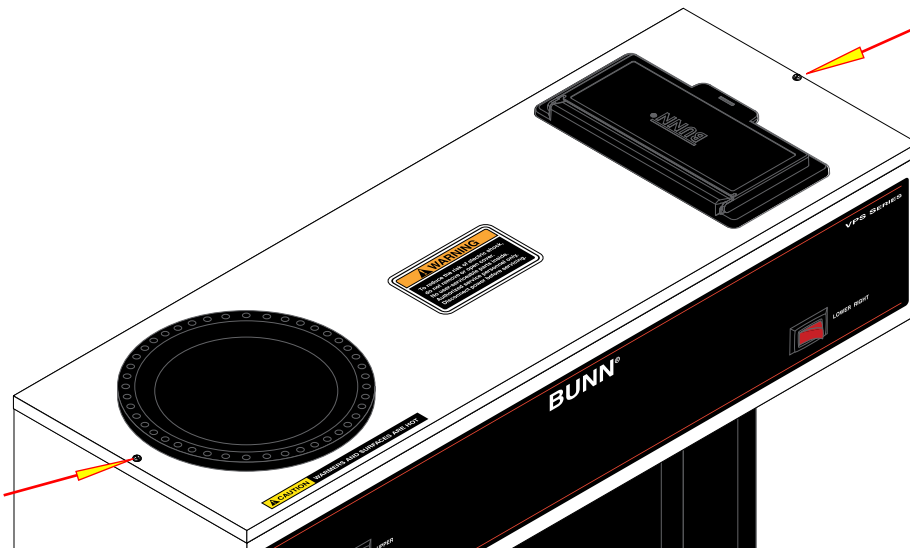
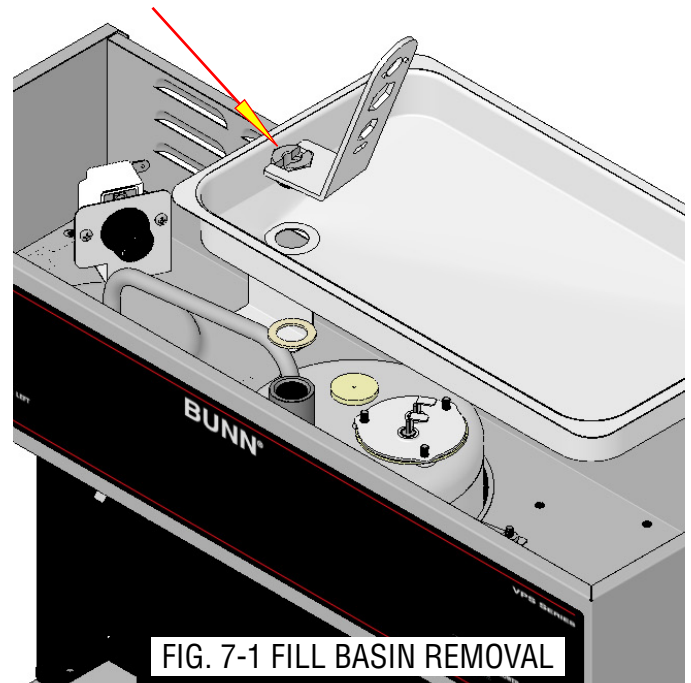

P3447.70

SERVICE (cont.)

CONTROL THERMOSTAT

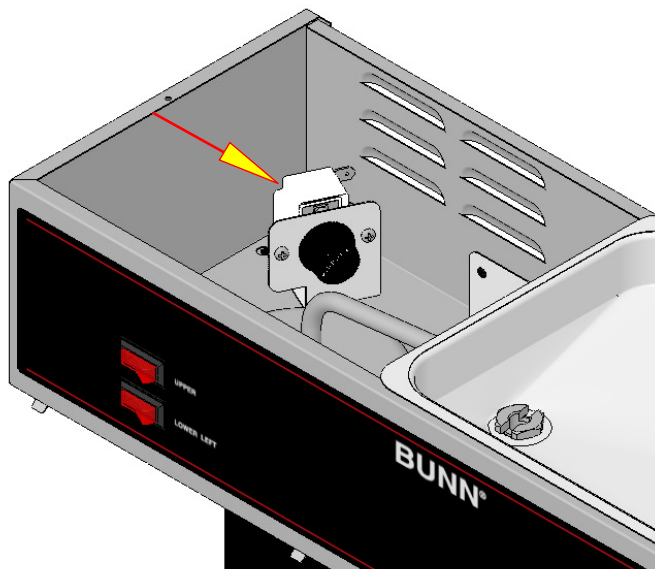

FIG. 8-1 CONTROL THERMOSTAT

Location:

The control thermostat is located inside the hood.

Test Procedures:

1. Disconnect the brewer from the power source.
2. Locate the black wire on the control thermostat.
3. Check the voltage across the black wire on the control thermostat and the white wire on the tank heater or the red wire on the tank heater with a voltmeter. Plug-in the brewer to the power source. The indication must be:
 - a) 120 volts ac for two wire 120 volt models.
 - b) 220 volts ac for two wire 220 volt models.
4. Disconnect the brewer from the power source.

If voltage is present as described, proceed to #5.
If voltage is not present as described, refer to the wiring diagrams and check the brewer wiring harness.

5. Locate the blue/black wire on the control thermostat.
6. Gently remove the capillary bulb and grommet from the tank.
7. Check the voltage across the blue/black wire of the control thermostat and the white wire on the tank heater or red wire on the tank heater with a

voltmeter when the control thermostat is turned "ON" (fully clockwise). Plug-in the brewer to the power source. The indication must be:

- a) 120 volts ac for two wire 120 volt models.
- b) 220 volts ac for two wire 220 volt models.

Voltage must not be present across these terminals when the thermostat is turned "OFF" (fully counterclockwise).

8. Disconnect the brewer from the power source.

If voltage is present as described, reinstall the capillary tube into the tank to the line 4.5" above the bulb, the control thermostat is operating properly.

If voltage is not present as described, replace the thermostat.

Alternate Test Procedure:

1. Disconnect the brewer from the power source.
2. Remove leads from control thermostat terminals.
3. Gently remove the capillary bulb and grommet from the tank.
4. Check for continuity across the control thermostat terminals. The indication must be:
 - a) Continuity "ON" (fully clockwise).
 - b) No continuity "OFF" (fully counterclockwise).

If continuity is not as described, replace the thermostat.

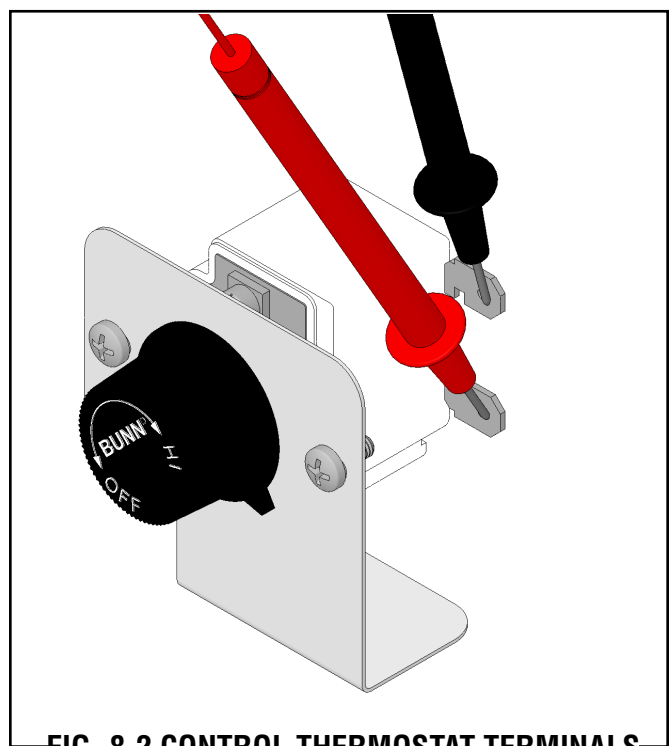

FIG. 8-2 CONTROL THERMOSTAT TERMINALS

SERVICE (cont.)

CONTROL THERMOSTAT (cont.)

Removal and Replacement:

1. Remove leads from control thermostat terminals.
2. Remove the thermostat capillary bulb by firmly pulling-up on the capillary at the tank lid. This will disengage the grommet from the tank lid.
3. Remove the two #6-32 screws securing the control thermostat to the mounting bracket inside the hood. **EARLY MODELS:** Remove the two #8-32 screws securing the control thermostat/bracket assembly to the tank lid bracket.

4. Slide the grommet to the line 4.5" above the bulb on the new capillary tube.
5. Insert the capillary bulb through the hole in the tank lid and press the grommet firmly and evenly so that the groove in the grommet fits into the tank lid.
6. Carefully bend the capillary tube so that the tube and bulb inside the tank are in the vertical position.

NOTE - The capillary tube must be clear of any electrical termination and not kinked.

7. Secure the control thermostat to the mounting bracket.
8. Adjust the control thermostat as required

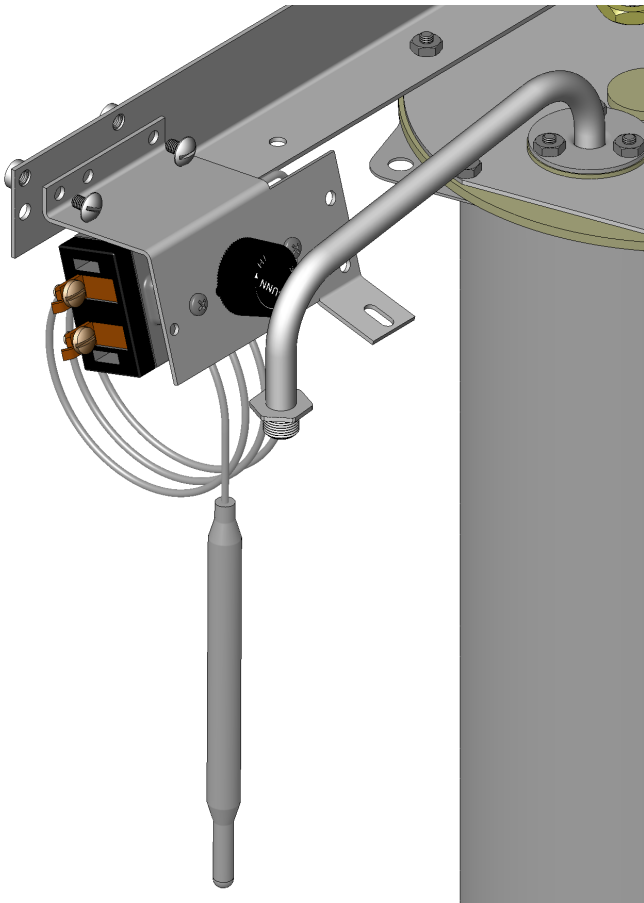

FIG. 9-1 CONTROL THERMOSTAT EARLY MODELS

LIMIT THERMOSTAT - VPR, VPS

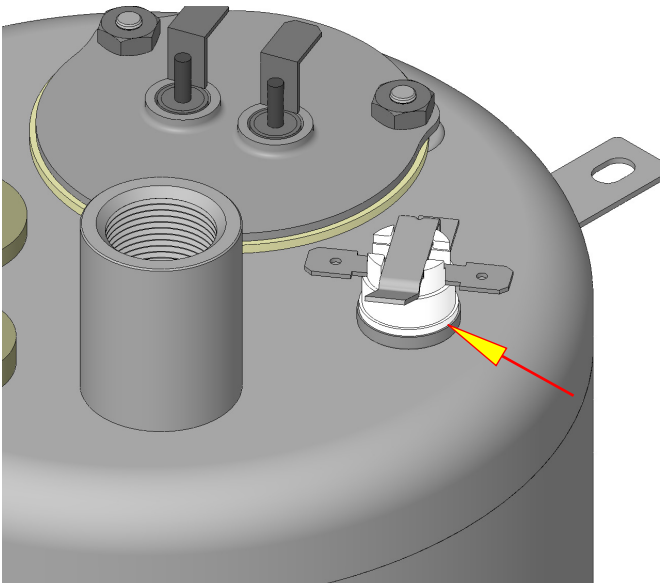

FIG. 10-1 LIMIT THERMOSTAT

Location:

The limit thermostat is located inside the hood on the right side of the tank lid.

Test Procedures:

1. Disconnect the brewer from the power source.
2. Disconnect the blue/black and black wires from the limit thermostat.
3. Check for continuity across the limit thermostat terminals with an ohmmeter.

If continuity is present as described, the limit thermostat is operating properly.

If continuity is not present as described, replace the limit thermostat.

Removal and Replacement:

1. Remove all wires from limit thermostat terminals.
2. Carefully slide the limit thermostat out from under the retaining clip and remove limit thermostat.
3. Carefully slide the new limit thermostat into the retaining clip.
4. Refer to wiring diagram when reconnecting the wires.

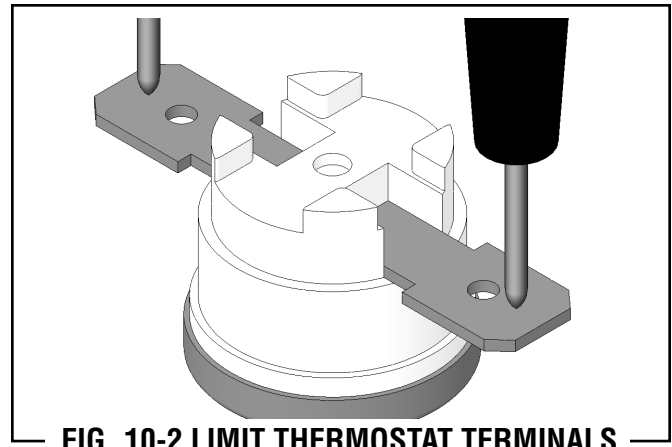

FIG. 10-2 LIMIT THERMOSTAT TERMINALS

SERVICE (cont.)

ON/OFF WARMER SWITCH

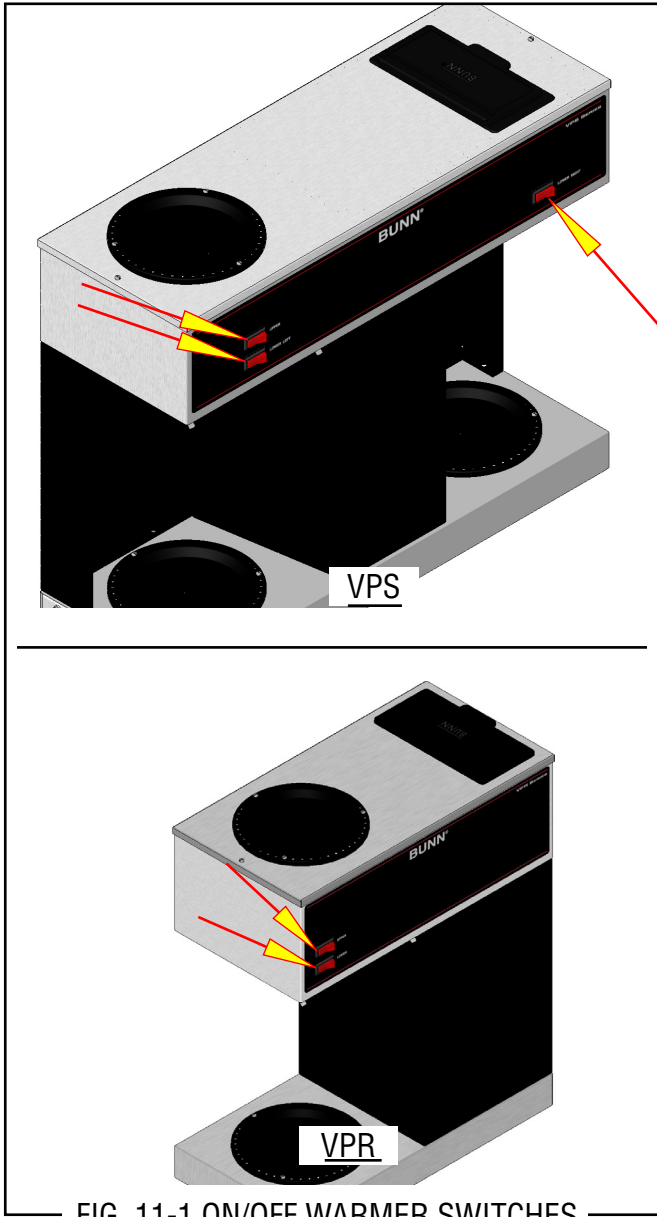

FIG. 11-1 ON/OFF WARMER SWITCHES

Location:

The ON/OFF warmer switches are located on the front of the hood.

Test Procedure:

1. Disconnect the brewer from the power source.
2. Viewing the switch from the back locate the black wire from the switch terminal.
3. With the switch in the "ON" position check the voltage across the black wire of the switch and the white wire on the lamp or red wire on the lamp with a voltmeter. Plug-in the brewer to the power source. The indication must be:

- a) 120 volts ac for two wire 120 volt models.
 - b) 220 volts ac for two wire 220 volt models.
4. Disconnect the brewer from the power source.

If voltage is present as described, proceed to #5. If voltage is not present as described, refer to the *Wiring Diagrams* and check the brewer wiring harness.

5. Remove both wires from the switch and check for continuity across the terminals with the switch in the "ON" position. Continuity must not be present when the switch is in the "OFF" position.

If continuity is present as described, reconnect the wires to the terminals. If continuity is not present as described, replace the switch.

Removal and Replacement:

1. Remove the wires from the switch terminals.
2. Compress the clips inside the hood and gently push the switch through the opening.
3. Push the new switch into the opening and spread the clips to hold switch in the hood.
4. Refer to Fig. 11-2 when reconnecting the wires

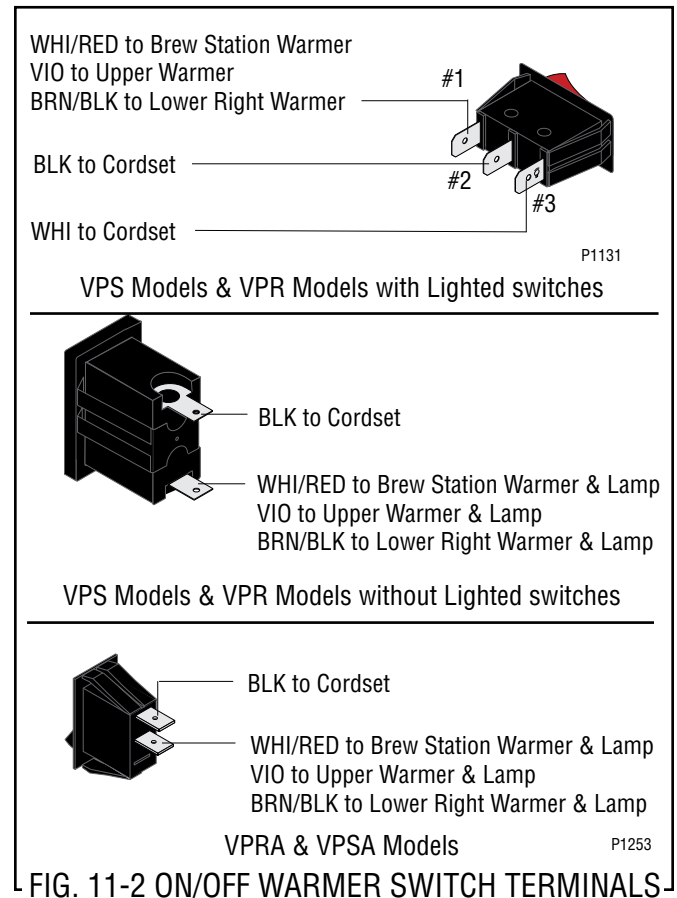

FIG. 11-2 ON/OFF WARMER SWITCH TERMINALS

SERVICE (cont.)

TANK HEATER

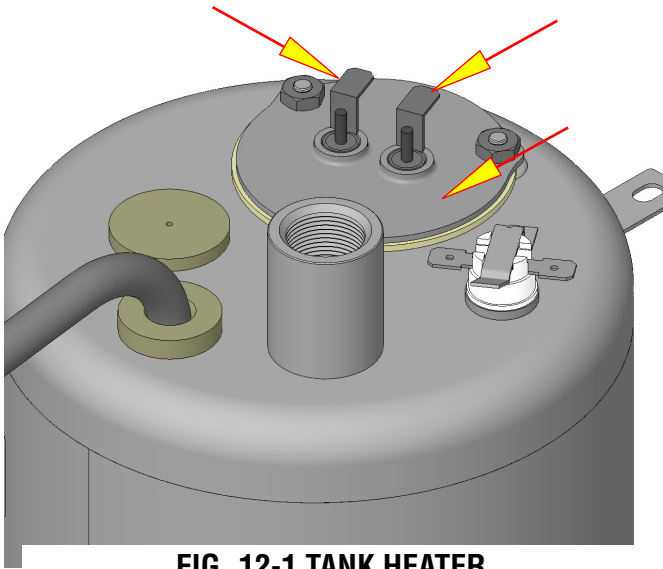

FIG. 12-1 TANK HEATER

Location:

The tank heater is located inside the tank and secured to the tank lid.

Test Procedures:

1. Disconnect the brewer from the power supply.
2. Check the voltage across the black and white wires on 120 volt models or the black and red wires for 220 volt models with a voltmeter. Plug the brewer into the power source. The indication must be:
 - a) *120 volts ac for 120 volt models.
 - b) *220 volts ac for 220 volt models.(* Control thermostat must be turned on)
3. Disconnect the brewer from the power source.

If voltage is present as described, proceed to #4

If voltage is not present as described, refer to the *Wiring Diagrams* and check wiring harness.

4. Disconnect the wires from the heater terminals.
5. Check for resistance across the tank heater terminals.
 - a) 11 ohms ($\pm 10\%$) for 120 volt models.
 - b) 26 ohms ($\pm 10\%$) for 220 volt models.

c) Infinite resistance between either terminal to the housing for *all* models. Any resistance reading to housing indicates heater is cracked allowing water to short the circuit and must be replaced.

If resistance is present as described, reconnect the wires, the tank heater is operating properly.

If resistance is not present as described, replace the tank heater.

Removal and Replacement:

1. Remove the tank inlet fitting securing the fill basin to the tank lid, remove fill basin and tank inlet gasket. Set all three parts aside for reassembly.
2. Disconnect the black wire on the terminal block from the tank heater and disconnect the blue/black wire from the limit thermostat or thermal cut-off to the control thermostat.
3. Disconnect the black wire and the white or red wire from the tank heater terminals.
4. Remove sprayhead and the hex nut securing the sprayhead tube to the hood. Set aside for reassembly.
5. Remove the eight #8-32 nuts securing the tank lid to the tank.
6. Remove the tank lid with limit thermostat or thermal cut-off, sprayhead tube and tank heater.
7. Remove the two hex nuts securing the tank heater to the tank lid. Remove tank heater with gaskets and discard.
8. Install new tank heater with gaskets on the tank lid and secure with two hex nuts.
9. Install tank lid with limit thermostat or thermal cut-off, sprayhead tube and tank heater using eight #8-32 hex nuts.
10. Secure sprayhead tube to hood using a hex nut.
11. Install sprayhead.
12. Reconnect the wires to the limit thermostat or thermal cut-off, tank heater and control thermostat. See limit thermostat, thermal cut-off and control thermostat sections in this manual when reconnecting wires.
13. Install fill basin, secure with tank inlet fitting and gasket.
14. Refer to wiring diagram when reconnecting the tank heater wires.

SERVICE (cont.)
THERMAL CUT-OFF - VPRA, VPSA

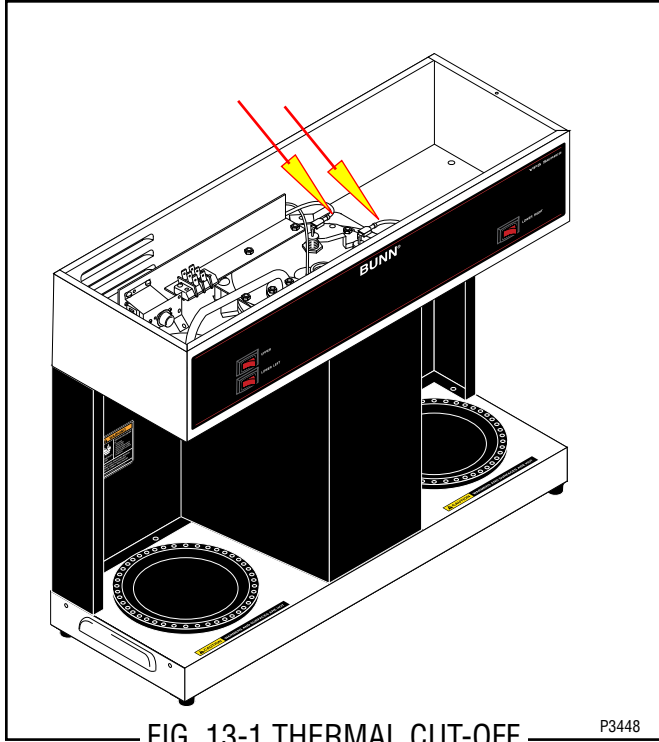

Location:

The thermal cut-outs are located inside the hood connected to the tank heater terminals.

Test Procedures:

1. Disconnect the brewer from the power source.
2. Disconnect the thermal cut-off from the tank heater and the red wire from the power connector.
3. Check for continuity across the thermal cut-off terminals with an ohmmeter.

If continuity is present as described, the thermal cut-off is operating properly.

If continuity is not present as described, replace the thermal cut-off.

4. Disconnect the thermal cut-off from the tank heater and blue/black from the control thermostat.
5. Check for continuity across the thermal cut-off terminals with an ohmmeter.

If continuity is present as described, the thermal cut-off is operating properly.

If continuity is not present as described, replace the

thermal cut-off.

Removal and Replacement:

1. Disconnect the thermal cut-off from the tank heater and the red wire from the power connector or the blue/black wire from the control thermostat.
2. Install new thermal cut-off.
3. Refer to Fig. 13-2 when reconnecting wires.

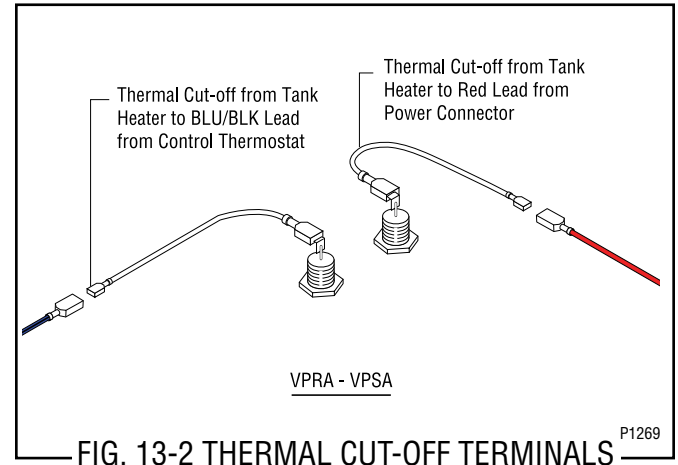

SERVICE (cont.)

WARMER ELEMENTS

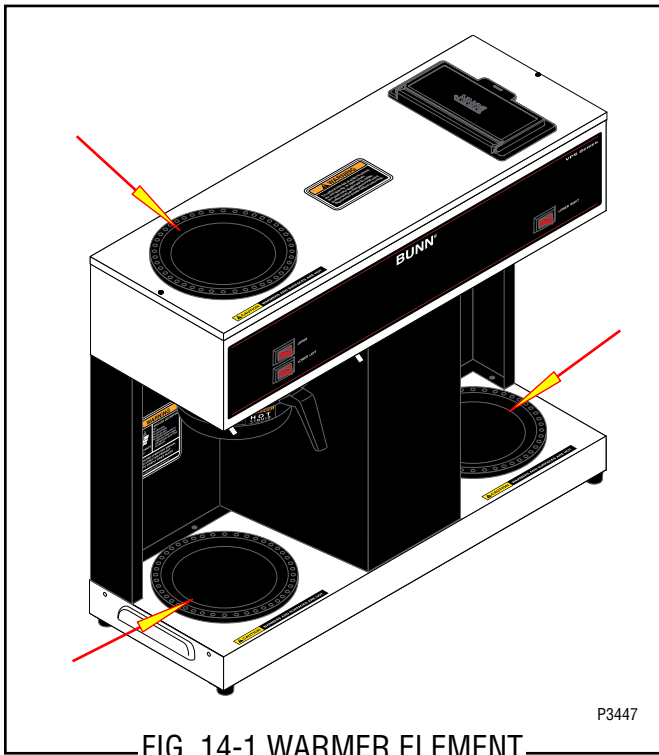

Location:

The warmer elements are located under the warmer plates.

Test Procedures:

1. Disconnect the brewer from the power source.
2. Use the white to the power cord or red wire to the power connector and the white/red, violet or brown/black wire on the "ON/OFF" switch.
3. Check voltage across the white or red and white/red, violet or brown/black with a voltmeter with the "ON/OFF" switch in the "ON" position. Plug-in the brewer to the power source. The indication must be:
 - a) 120 volts ac for two wire 120 volt models.
 - b) 220 volts ac for two wire 220 volt models.
4. Disconnect the brewer from the power source.

If voltage is present as described, proceed to #5.
If voltage is not present as described, refer to wiring diagrams and check brewer wiring harness.

5. Remove both wires from the warmer element and check the continuity across the two terminals on the warmer element.

If continuity is present as described, reconnect the wires on the warmer element.

If continuity is not present as described, replace the warmer element.

Removal and Replacement:

1. Remove the three #4-40 screws securing the warmer assembly to the brewer.
2. Lift the warmer assembly from the brewer.
3. Disconnect the two wires from the warmer element terminals.
4. Remove the two #8-32 nuts securing the warmer element to the warmer plate.
5. Securely install new warmer element.
6. Reconnect the two wires to warmer element terminals.
7. Securely install warmer assembly on the brewer.
8. Refer to Fig. 14-2 when reconnecting the wires.

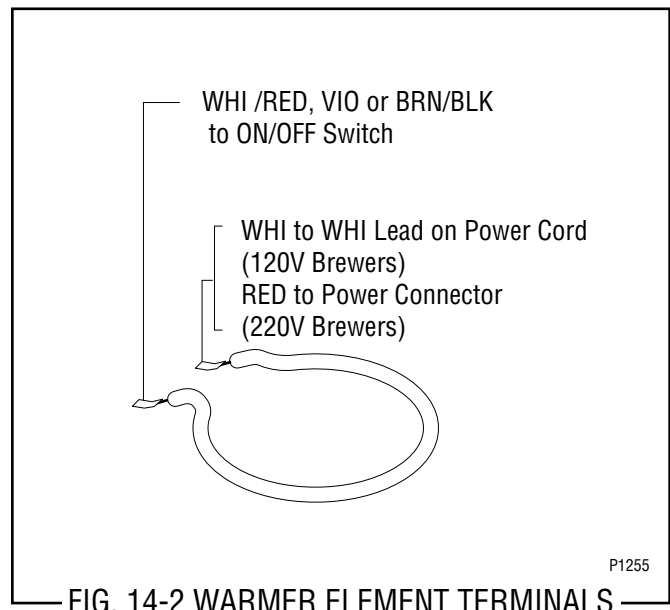

SCHEMATIC WIRING DIAGRAM VPR

(Models without Lighted switches)

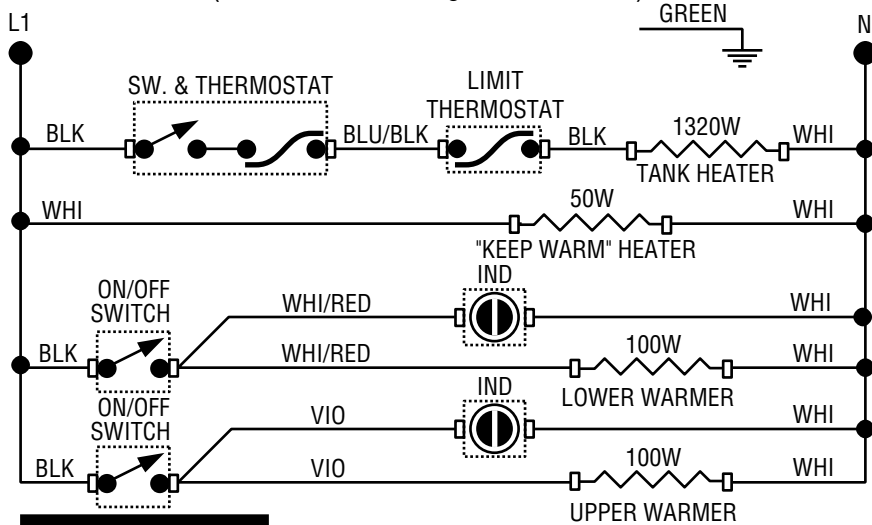

**120 VOLTS A C
2 WIRE
SINGLE PHASE
60 HZ**

10050.0000D 1/97 © 1988 BUNN-O-MATIC CORPORATION

SCHEMATIC WIRING DIAGRAM

VPR, VPR TC & VPR APS

(Models with Lighted switches)

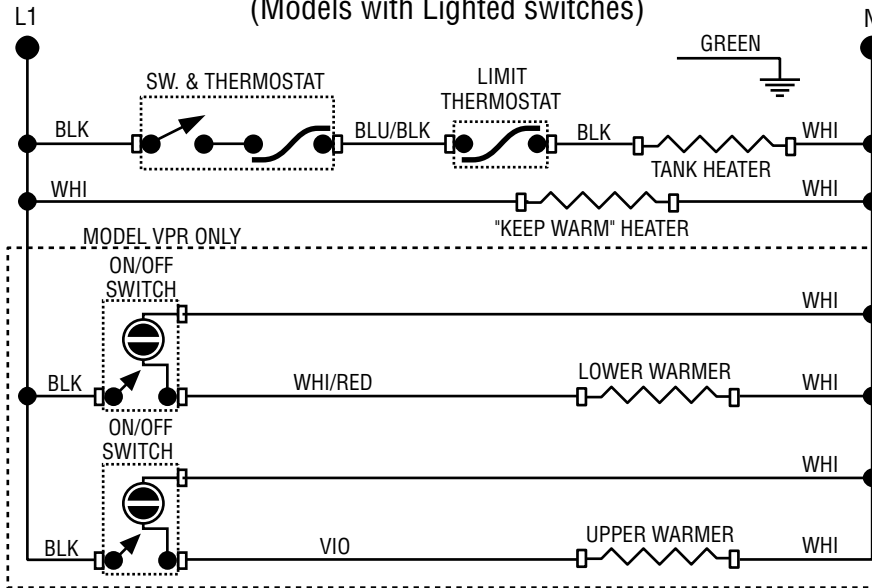

**120 VOLTS A C
2 WIRE + GND
SINGLE PHASE
60 HZ**

33769.0000D 03/07 © 2001 BUNN-O-MATIC CORPORATION

SCHEMATIC WIRING DIAGRAM VPS

(Models without Lighted switches)

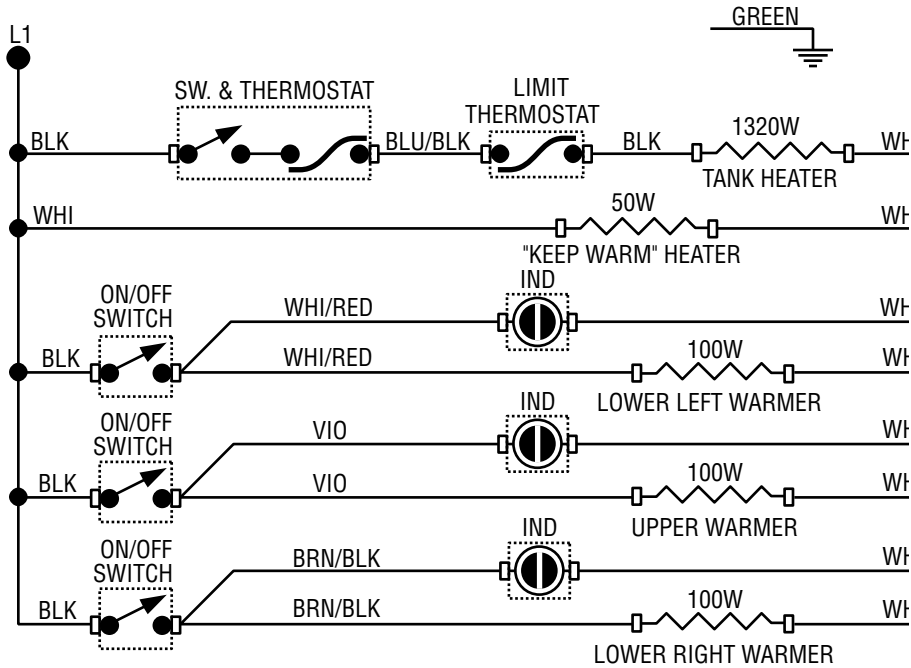

**120 VOLTS A C
2 WIRE
SINGLE PHASE
60 HZ**

10049.0000C 1/97 © 1988 BUNN-O-MATIC CORPORAT

SCHEMATIC WIRING DIAGRAM VPS

(Models with Lighted switches)

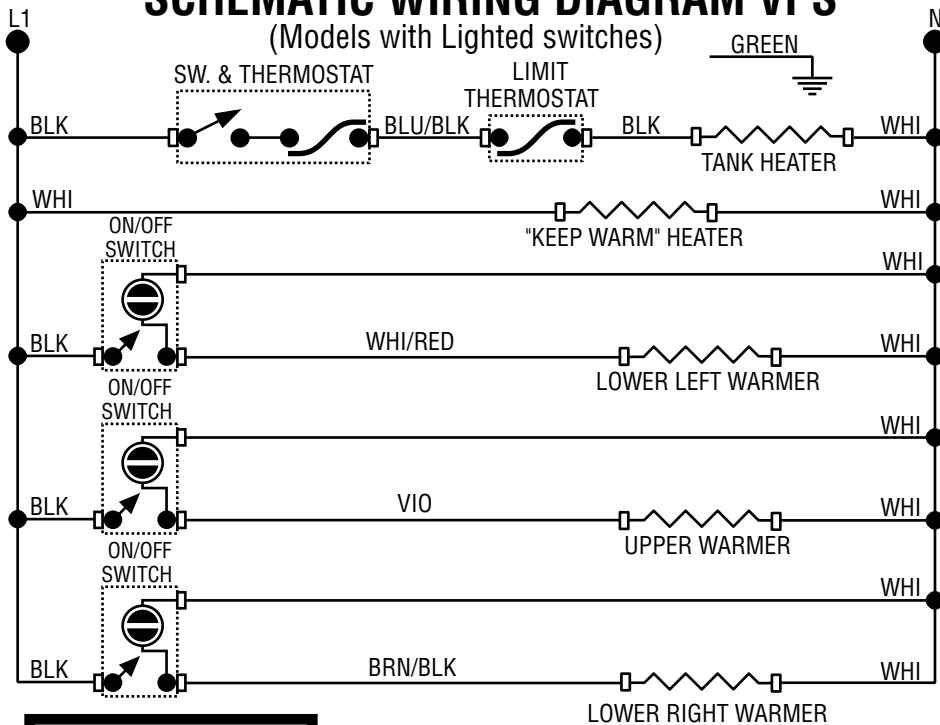

**120 VOLTS A C
2 WIRE
SINGLE PHASE
60 HZ**

10049.0001A 08/04 © 2004 BUNN-O-MATIC CORPORATION

SCHEMATIC WIRING DIAGRAM VPSA

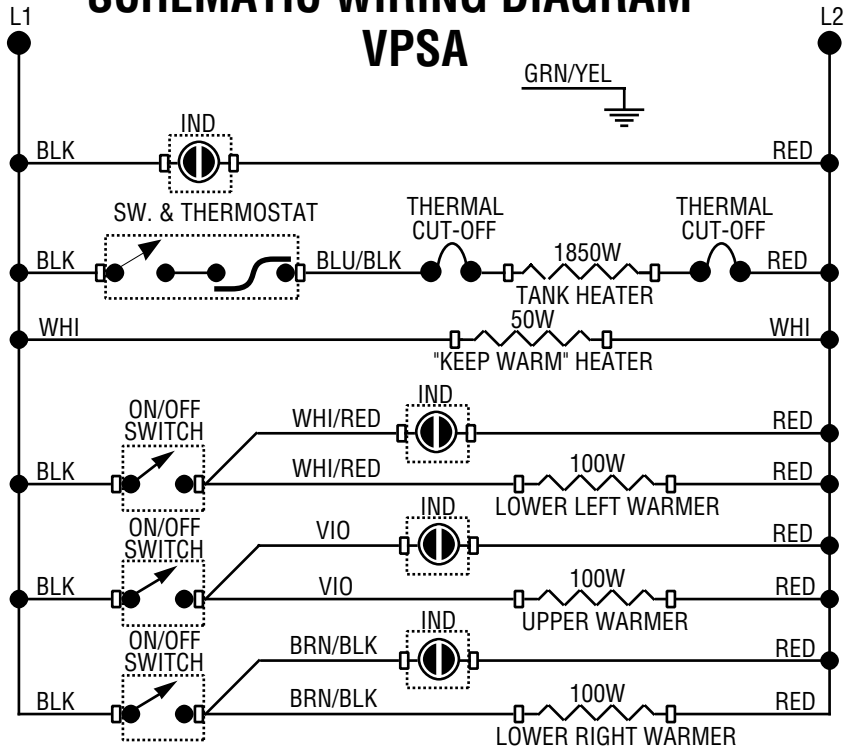

**220 VOLTS A C
2 WIRE
SINGLE PHASE**

10095.0000E 1/97 ©1988 BUNN-O-MATIC CORPORATION

SCHEMATIC WIRING DIAGRAM VPRA

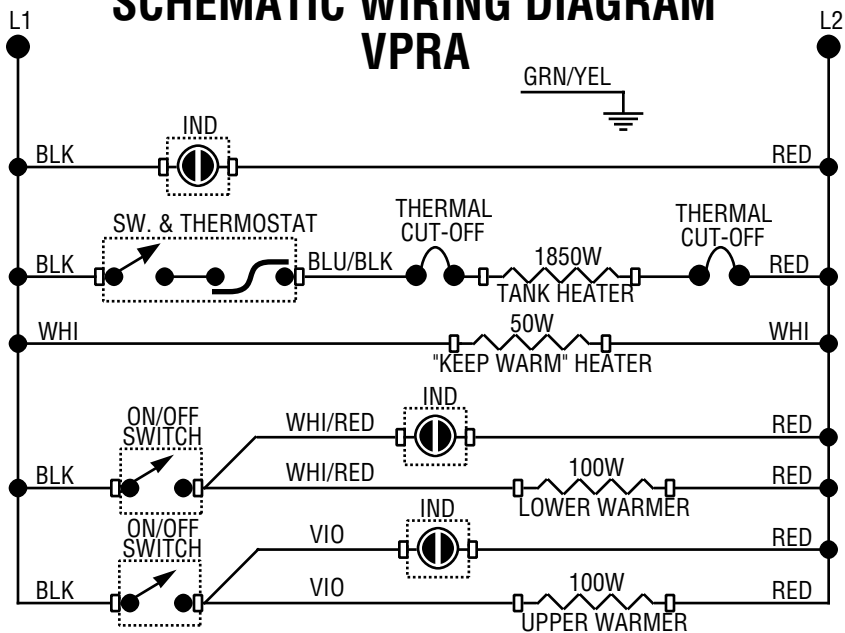

**220 VOLTS A C
2 WIRE
SINGLE PHASE**

10096.0000E 1/97 ©1988 BUNN-O-MATIC CORPORATION