

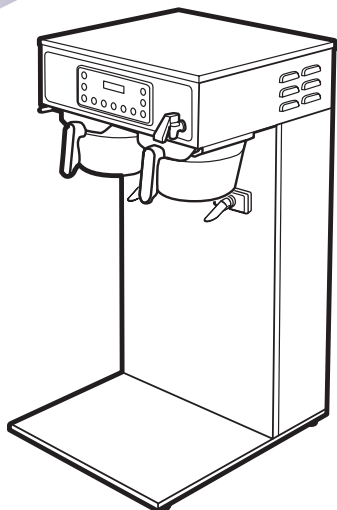

WILBUR CURTIS COMPANY, INC.

Service Manual – Combo Brewer High Volume Twin



Model

■ CBHVT



CAUTION: Please use this setup procedure before attempting to use this brewer. Failure to follow the instructions can result in injury or the voiding of the warranty.



IMPORTANT: Equipment to be installed to comply with applicable governmental plumbing/electrical codes having jurisdiction.



CAUTION: DO NOT connect this brewer to hot water. The inlet valve is not rated for hot water.



ISO 9001:2008 REGISTERED

WILBUR CURTIS CO., INC.
6913 West Acco Street
Montebello, CA 90640-5403
For the latest information go to
www.wilburcurtis.com
Tel: 800-421-6150
Fax: 323-837-2410

Important Safeguards/Symbols

This equipment is designed for commercial use. Any servicing other than cleaning and routine maintenance should be performed by an authorized Wilbur Curtis Company Service Technician.

- DO NOT immerse the unit in water or any other liquid
- To reduce the risk of fire or electric shock, DO NOT open service panels. There are no user serviceable parts inside.
- Keep hands and other items away from hot areas of the unit during operation.
- Never clean with scouring powders or harsh chemicals.

Symbols:



WARNINGS – To help avoid personal injury



Important Notes/Cautions – from the factory



Sanitation Requirements

This Curtis Generation 3 Unit is Factory Pre-Set and Ready to Go Right from the Box.

Following are the Factory Settings for your G3 Coffee Brewing System:

- Brew Temperature = 200°F
- Water Bypass = On for LARGE & MEDIUM Brew Only
- Brew Volume = Set to Vessel Requirement.

System Requirements:

- Water Source 20 – 90 PSI (Minimum Flow Rate of 1 GPM)
- Electrical: See attached schematic for standard model or visit www.wilburcurtis.com for your model.

SETUP STEPS

1. The unit should be level (left to right - front to back), on a secure surface.
2. Connect the water line to the water inlet fitting on the rear of the unit. Water volume flow to the machine should be consistent. Use tubing sized sufficiently to provide a minimum flow rate of one gallon per minute.



NOTE: A water filtration system must be used to help maintain trouble-free operation. In areas with extremely hard water, we highly recommend the use of a Curtis approved water filter. For our full line of filters, please log on to www.wilburcurtis.com. A water filtration system will greatly prolong the life of the unit and enhance the quality and taste of the product.



NSF International requires the following water connection:

1. A quick disconnect or additional coiled tubing (at least 2x the depth of the unit) is required so that the unit can be moved for cleaning.
2. This unit must be installed with adequate backflow protection to comply with applicable federal, state and local codes.
3. Water pipe connections and fixtures directly connected to a portable water supply shall be sized, installed and maintained in accordance with federal, state, and local codes.

3. Connect the unit to electrical outlet with appropriate amperage rating (see serial tag on machine).

4. Once power has been supplied to the unit, flip the toggle switch to the 'ON' position (located on the rear of the unit), the water tank will begin to fill. When the water level in the tank reaches the probe, the heating element(s) will turn on.

5. Water in the heating tank will require approximately a half hour before reaching operating temperature (factory setting of 200°F). Where applicable, turn on the Universal Control Module (UCM). When the unit reaches operating temperature, it will display "READY TO BREW".

FOR THE LATEST SPECIFICATIONS AND INFORMATION GO TO WWW.WILBURCURTIS.COM

COFFEE BREWING INSTRUCTIONS

1. Brewer should be ON (Confirm at rear toggle switch, then press the ON/OFF button). Ready-to-Brew should be on the display.
2. Place an empty coffee container under the brewcone. Make sure the container is open at the top and it is centered under the brewcone.

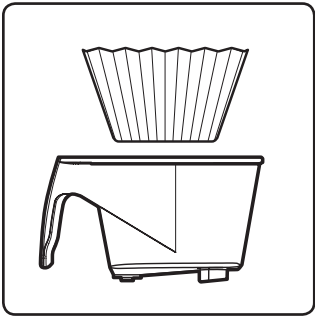

3. Place a clean filter into the brewcone marked "COFFEE".

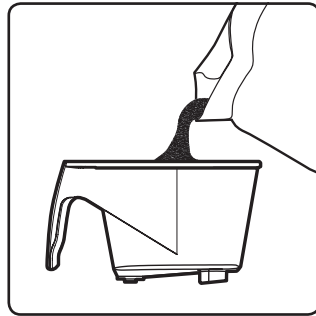

4. Fill the brewcone with the proper amount of ground coffee.

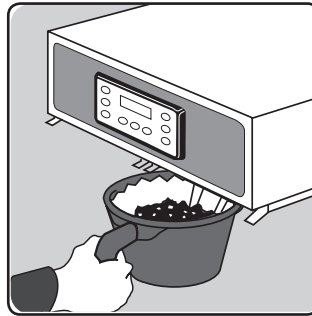

5. Slide the filled brewcone into rails on the brewer.

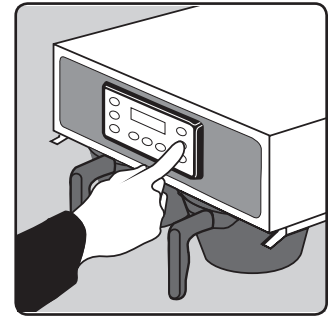

6. Select the appropriate COFFEE brew button and press to start the brew cycle.



WARNING TO AVOID SCALDING, Do not remove the brewcone or coffee container until the UCM screen indicates that the brew cycle has finished.

TEA BREWING INSTRUCTIONS

1. Brewer should be ON (Confirm at rear toggle switch, then press ON/OFF button) and Ready-to-Brew displayed.
2. Make sure tea container is correctly placed on the brew deck, centered under the brewcone.

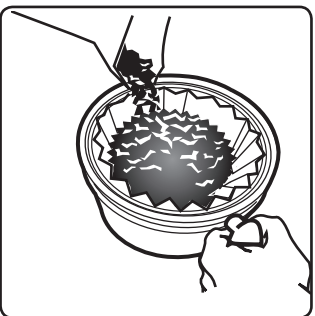

3. Place a new filter into the brew basket. Pour leaf tea into the brewcone marked ICED TEA.

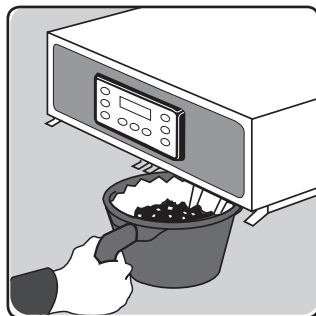

4. Slide the filled brew cone into brew rails.

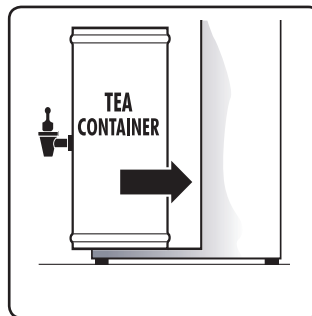

5. Slide container all the way in against the center wrap.

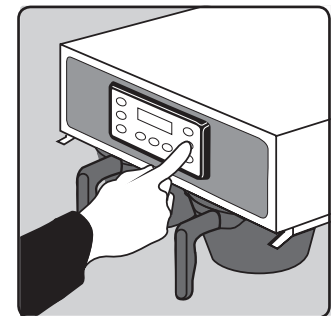

6. Press the TEA BREW button to start brewing tea.

Quick Start

CBHVT

Your Curtis G3/Gold Cup Series is Factory Pre-Set for Optimum Performance.

After connection to water and power; the rear toggle switch must be on. You will hear a beep sound, indicating power is available to the controller.

The control displays **CURTIS** Press ON/OFF button and the screen will display **<CBHVT>
CURTIS**. After three seconds, **CURTIS
FILLING** is displayed.

Water will fill the tank (approximately 2-3 minutes depending on water flow rate). When the proper level is reached **CURTIS
HEATING** will appear on the screen. It takes approximately 20 minutes to reach the set point temperature.

Control will display **CURTIS
READY TO BREW** when temperature reaches the set point. The unit is now ready to brew.

Programming with the Universal Control Module (UCM)

Turn off the control panel by pressing ON/OFF button. Press and hold bottom/right coffee brew button (#4 in illustration) and then press and release the ON/OFF button.

Continue holding the bottom-right brew button. The screen will display **ENTERING
PROGRAM MODE**, wait until **ENTER CODE** is displayed. Enter the 4-digit access code, the code corresponds to the buttons illustrated below. The default code set at the factory is 1-2-3-4.

After the 4-digit code is entered, **PROGRAM MENUS
< SELECT >** will be displayed. You can now enter the program menu features.

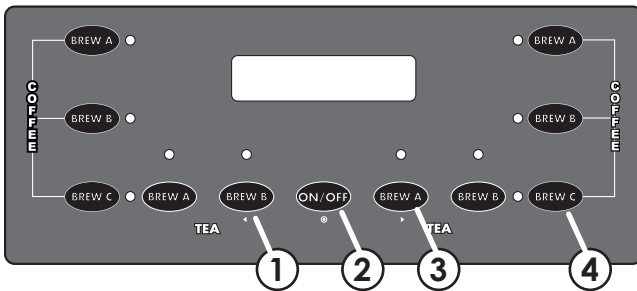

All programming selections are performed with the three center buttons. The symbols near the buttons are:

- ◀ Scroll LEFT
- ⊙ SELECTION or ENTER to save new parameter
- ▶ Scroll RIGHT

PROGRAM MENUS COMBO BREWER

Program Menus	From Program Menus press > display will show the next feature Global Recipes.
Global Recipes	Global Recipes (Factory set to Gourmet STD) This is a coffee option. Press ⊙ to select. If selected, press < or > to chose a coffee recipe: Gourmet STD, Light Roast, Dark Roast, High Yield, Filter Pack, or Decaf. Press ⊙ to select the desired recipe.
Non-Brew Program	Non-Brew Program Press ⊙ to Select or < > to pass by these options and continue to the next group. The selections for Non-Brew Program are listed below.
Temperature	Temperature (Factory set to 204°F) Press ⊙ to Select. Press < or > to move to desired temperature and then ⊙ to set. Temperature is programmable from 170°F to 208°F in 2-degree increments.
Energy Save Mode	Energy Save Mode (Factory set to OFF) Press ⊙ to Select, < or > ON, OFF or ON 140°F, ⊙ to set. When in ON, unit will automatically shut off 4 hours from last brew. When feature is OFF, unit does not utilize the energy saving mode. In the ON 140°F position, temperature lowers to 140°F, if unit has not brewed in 4 hours. This feature will save energy by maintaining a lower temperature in the tank in periods of non-operation.
Brew Count Odom	Brew Count Odom Press ⊙ to display total brew cycles. Press EX or Reset.
Brew Count Total	Brew Count Total Press ⊙ to Select, Shows total gallons and total brew cycles on the unit. Cannot be reset.

Cold Brew Lock	<p>Cold Brew Lock . . . (Factory set to 5°) Press \odot to select, < or > to select desired setting (CBL 5, 15 or OFF), \odot to set. The Cold Brew Lock feature allows the brewer to brew at three different temperature levels from the actual set point. The first setting is within 5 degrees of set point, next is within 15 degrees of set point, OFF is within 30 degrees of set point for the Ready to Brew message, however, it will brew at any temperature.</p>
Master Reset	<p>Master Reset Press \odot to display Are You Sure? Then < for Yes, > for No. Brewer factory defaults are then reset.</p>
Service Call	<p>Service Call (Phone number Factory set to 1-800-000-0000 X0000) Press \odot to display number and change number or < to move place and EX to exit when complete. This number will be displayed during a Heating system SENSOR ERROR or during a WATER ERROR.</p>
Access Code	<p>Access Code (Factory set to 1-2-3-4) Press \odot to display number and change number, (the number can be changed 1 to 4) or < to move place and EX to exit when complete.</p>
Banner Name	<p>Banner Name (Factory set to CURTIS) Press \odot to display letters and change letters or < to move place and EX to exit when complete This feature allows up to 14 letters to be programmed for company name or regional name. Programming all blanks disables Banner Name. If programmed, Banner Name is displayed every 5 sec. on and off.</p>
P-Maintenance	<p>P-Maintenance (Factory set to OFF) Press \odot to Select, Set gallons brewed to indicate P-Maintenance. Press < or > to adjust from Off to 9500 gallons. This feature advances in 500 gallon increments. Press \odot to exit.</p>
Beeper On/Off	<p>Beeper On/Off (Factory set to ON) Press \odot to display ON or OFF. Pressing either < or > toggles between on and off. \odot to set. When ON, this feature allows you to hear a short beep each time a button is pressed.</p>
Coffee Drip-out Mode	<p>Coffee Drip-out Mode (Factory set to 2 minutes) Press \odot to Select. Press < or > to move to desired time. Settings are OFF, 1, 2, 3, 4 and 5 minutes. Press \odot to Select time.</p>
Tea Drip-out Mode	<p>Tea Drip-out Mode (Factory set to OFF) Press \odot to Select. Press < or > to move to desired time. Settings are OFF, 1, 2, 3, 4 and 5 minutes. Press \odot to Select time.</p>
Displ. Brew Time	<p>Displ. Brew Time (Factory set to ON) Press \odot to display ON or OFF. Pressing either < or > toggles between on and off. After Display Brew Time an EXIT screen will return you to Brew Button Prog.</p>
<hr/>	
Brew Button Prog	<p>Brew Button Program This is the next group of options in the sequence. The screen will prompt you to choose tea or coffee. Coffee options are shown below. Tea options are shown on page 5.</p>
<hr/>	
Select Button	<p>Select Button This is a temporary screen message indicating you are in the coffee brew button programming mode. Select a coffee brew button on the control module.</p>
Brew By Volume	<p>Brew by Volume (Factory settings: LARGE 200oz \pm8oz. MEDIUM 132oz\pm4oz. SMALL 64oz\pm4oz.) Press \odot to Select. Display will ask you to select a brew button, Large, Medium or Small. Press the desired brew button to begin... when desired volume is reached press the same brew button to stop the flow. Now the volume has been set.</p>
Brew By Time	<p>Brew by Time (Factory settings: LARGE 5min-25sec. MEDIUM 3min-32sec. SMALL 1min-52sec.) Next item in the sequence is Brew by Time. Press \odot to Select to change the brew time. Display will now show the current time. By pressing < or > you can toggle back and forth from minutes to seconds to exit (ex). Change the time or set and exit by pressing the \odot button.</p>

Pre-infusion

Pre-Infusion (Factory Disabled)

Press **⊙** to Select. Current setting in seconds is displayed < to decrease or select > to increase (range from OFF to 10 through 60 seconds), **⊙** to set.

If Pre-infusion is selected (ON), Cold Brew Lock is set to Delta 1 within 5°F of set point and Cold Brew Lock disappears from the list of program selections. When Pre-infusion is ON, Pulse Brew disappears from the list of program selections.

Pulse Brew

Pulse Brew (Factory setting C)

Press **⊙** to select, < or > to select OFF or one of five pulse patterns (A to E) . The five Pulse Brew options help “tune” or change the coffee flavor.

Guidelines for Pulse Brew:

Filter Pack type coffees typically extract better with the **A** and **B** pulse setting.

Decaf coffees typically extract better with the **B** pulse setting.

High-Yield coffees typically extract better with the **C** pulse setting. Of course, any of the **A**, **B** or **C** settings may be used to suit your taste profile.

Settings **D** and **E** are manual pulse counts.

To exit from the Pulse Brew mode, select 0 for the time.

If Pulse Brew is turned on, Cold Brew Lock is set to Delta 1 within 5°F of set point and Cold Brew Lock disappears from the list of program selections. When Pulse Brew is on, Pre-infusion disappears from the list of program selections.

By-Pass

By-Pass (Factory settings: LARGE 35%. MEDIUM 10%. SMALL Off.)

The By-Pass option helps with controlling extraction with larger brews. Contact time that is too long will extract undesirable bitter, harsh flavor compounds. By-passing some of the brew water around the coffee bed will balance the extraction.

Press **⊙** to display current setting. Press < or > to change settings; OFF, 5% to 50%, in 5% increments. Press **⊙** to set.

Select Button

Select Button – You may select a tea brew button to program from the buttons on the control module.

Tea By Volume

Tea by Volume

Press **⊙** to Select. The display will read Select Brew Button. Once the desired brew button is selected, the display will read Press BREW to Start and hot water starts dispensing. When the desired volume is reached, press the brew button again to stop the flow. The brew volume has now been set. When EXIT is displayed, Press **⊙** to select and exit.

Tea By Time

Tea by Time (Factory set to Full 3 min 32 sec, Half 1 min 46 sec)

Press **⊙** to Select. Press < or > to increase or decrease time. Tea by Time has a range of 0:00 to 9:59 (Increments are minutes and seconds). The HALF BREW button will be set at half the brew time.

Tea Dilut. Delay

Dilution Delay (Factory set to Full 30 sec, Half 30 sec)

Press **⊙** to Select. Press < or > to toggle between Standard-Gray (30 sec), Standard-Purple (30 sec), Tropical-Gray (9 min), Tropical-Purple (9 min), 76/308-Gray (4 min) and 76/308-Purple (4 min). Range is from 0 seconds, 30 seconds to 10 minutes; in 30 second increments.

Tea Dilut. Volume

Dilution Volume

Press **⊙** to Select, Display will now show Push START To Begin... Press the BREW button then water starts running, when desired volume is reached press BREW button again to stop the flow. Now the volume has been set. Pressing > button will display the subsequent menu features.

Tea Dilut. Time

Dilution Time (Factory set to Full 4 min 5 sec, Half 2 min 2 sec)

Press **⊙** to Select. Press < or > to toggle between Standard-Gray (4min-5sec), Standard-Purple (4min-5sec), Tropical-Gray (4min-26sec), Tropical-Purple (4min-26sec), 76/308-Gray (4min-55sec) and 76/308-Purple (4min-55sec). Dilution Time is from 30 sec to 9 min, 59 sec.

Tea Pulse Brew

Tea Pulse Brew (Factory set to OFF).

Press **⊙** to Select, press < or > to choose ON, OFF, or D. Selecting ON will give a pulsing pattern of 1 to 20 pulses. In D, the pulse time can be set for ON, 5 to 150 seconds (adjustable in 5 sec increments). Off time 5 to 150 seconds, adjustable in 5 second increments.

Sweetener Time

Sweetener Time (Factory set to Full 10 sec, Half 0 sec)

Sweetener Time is only for brewers with the optional tea sweetening system.

Press **⊙** to Select. Press < or > to toggle between minutes, seconds or exit. Pressing select **⊙** to choose minutes will increase the minutes. Press **⊙** to add minutes. Press < or > to move to seconds or exit. Setting the time to zero (0) will disable the Sweetener Time feature.

Model Select

Model Select (Factory set to CBHV-Single)

Press \odot to select, < or > to select model. The selections are: CBHV-Twin, CBHV-Single, CBHV-Twin SW, and CBHV-SingleSW. Press \odot to set. When the Model Select feature is changed, all settings are reset to the defaults of the newly selected model.

Batch Select Coffee

Batch Select (Factory set to Three Batch)

This feature will give you a choice to select one, two, or three active brew buttons per brew head. At this time, select only Three Batch.

Tea Recipes

Tea Recipes (Factory set to Standard - Amber)

This is a tea feature. Press \odot to select. If selected, press < or > to chose a tea recipe: Standard - Amber, Tropical - Amber, or 76/308 - Amber. Press \odot to select the desired recipe.

Control Module Menu Tree

The flow chart displays the sequence of menu item that can be accessed through the UCM. Various menu items will immediately exit the programming mode when selected. Other menu items, when selected, will continue to the next item in the menu list.

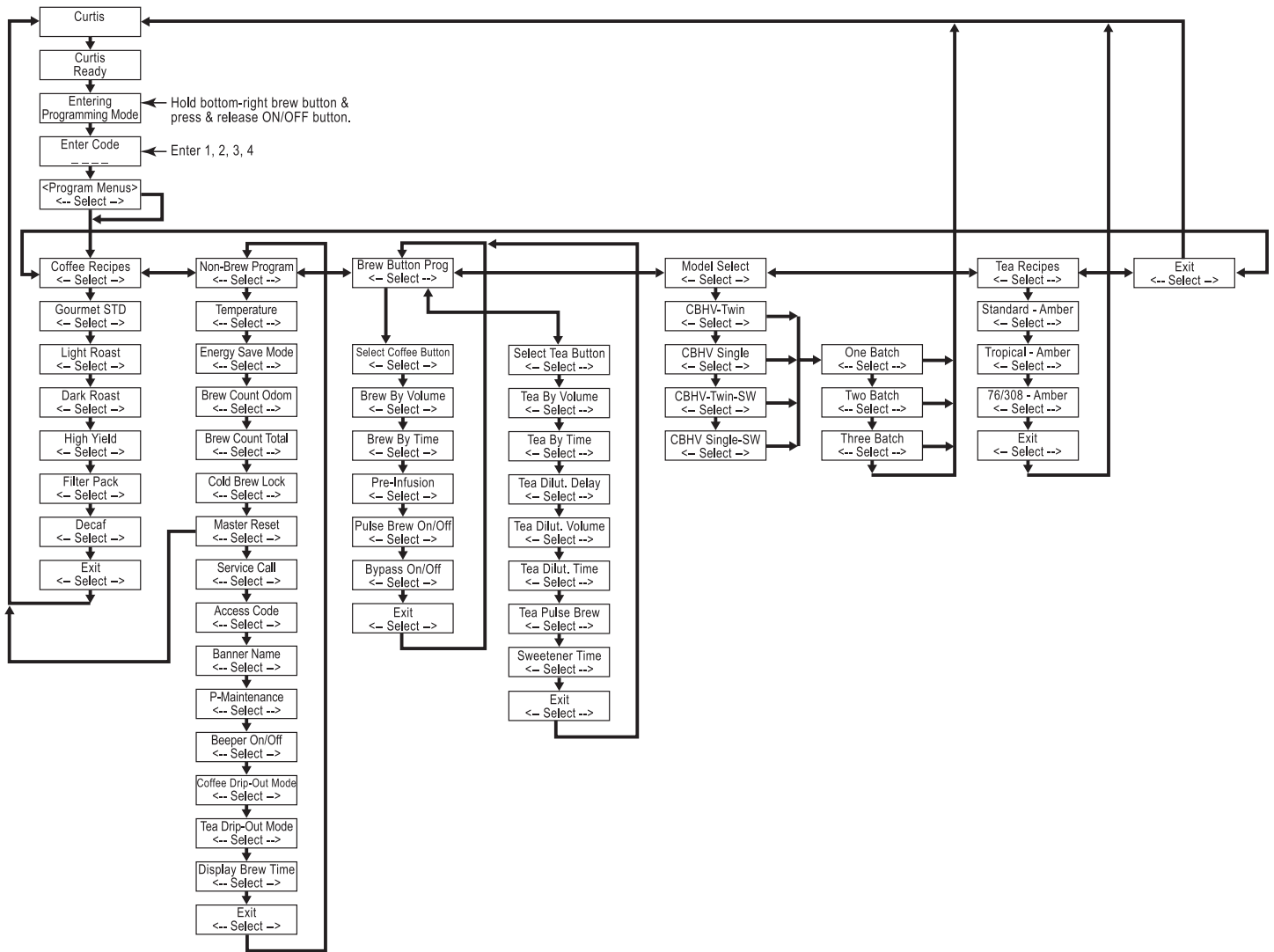

Illustrated Parts

Curtis High Volume Combo Coffee & Tea Brewer

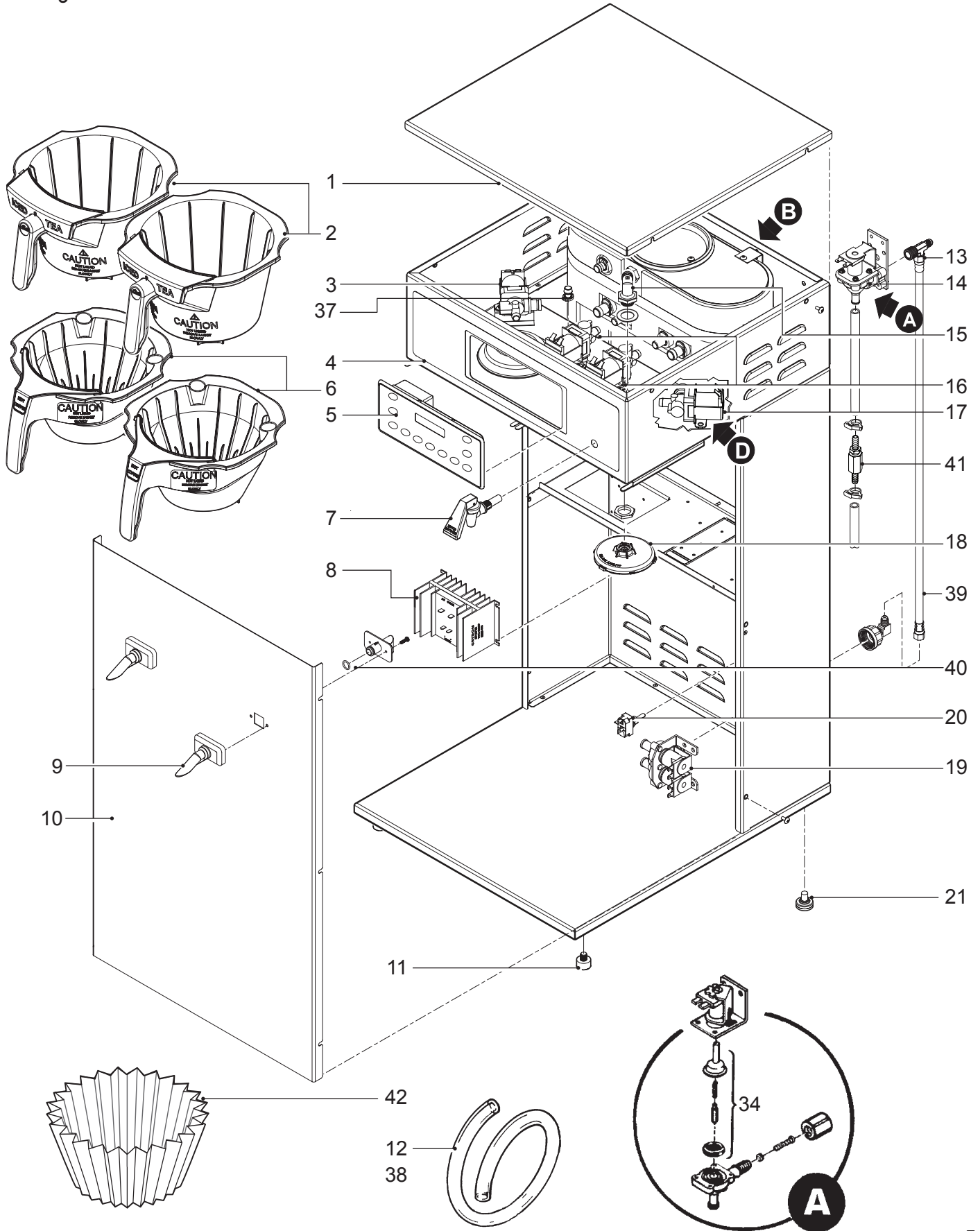

Illustrated Parts – Detail Bubbles

Curtis High Volume Combo Coffee & Tea Brewer

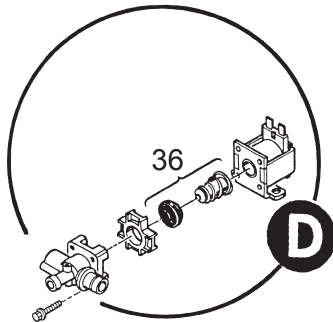
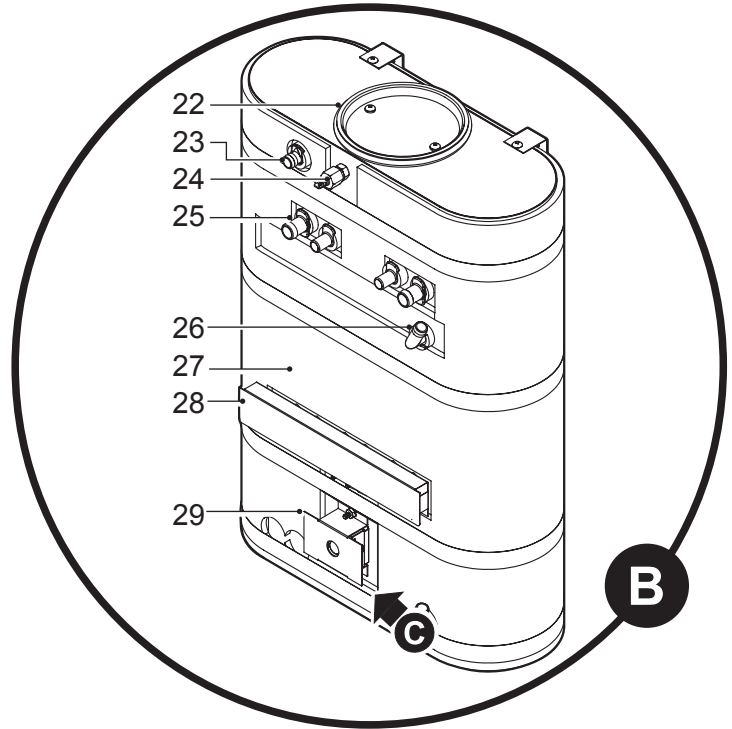
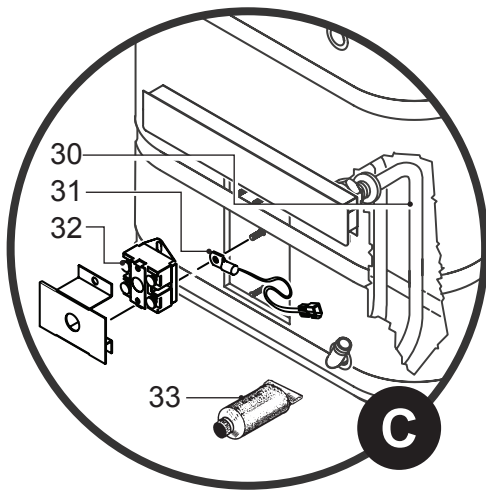

ITEM	PART N°	DESCRIPTION
1	WC-5421	COVER, TOP BREWER
2	WC-3398	BREW CONE, GOURMET NON-METAL TEA UNITS
3	WC- 821WDR*	VALVE, DUMP LEFT 120V 12W
4	WC-39845	LABEL, UCM OVERLAY COMBO TWIN
5	WC-37407*	KIT, UCM & LABEL CBHVT
6	WC-3417*	BREW CONE, ASSY W/SPLASH POCKET BROWN COFFEE
7	WC-1809*	FAUCET, HOT WATER
8	WC-8559*	RELAY, SOLID STATE W/INTEGRATED HEATSINK
9	WC-66079	SPOUT ASSY, DILUTION PLASTIC
10	WC-61619	COVER, FRONT
11	WC-3503	LEG, 3/8"-16 STUD SCREW BUMPER
12	WC-5310*	TUBING, 5/16" ID X 1/8"W SILICONE
13	WC-2705	FITTING, TEE 1/4" FLARE X 3/8 NPT X 1/4" FLARE PLTD
14	WC- 847*	VALVE, INLET 2 GPM 120V 10W GEN USE YELLOW
15	WC-2962-101K	KIT, FITTING SPRAYHEAD KYNAR
16	WC- 844-101*	VALVE, BY-PASS
17	WC-820WDR*	VALVE, DUMP RIGHT 120V 12W
18	WC-29050*	SPRAYHEAD, AMBER ADVANCED FLOW
19	WC- 895-104*	VALVE, DUAL DISPENSE 120V-10W .5GPM x 5GPM
20	WC- 102	SWITCH, TOGGLE SPST 15A 125VAC RESISTIVE
21	WC-3518*	LEG, GLIDE 3/8"-16 STUD SCREW
22	WC-37008*	KIT, TANK LID ROUND

ITEM	PART N°	DESCRIPTION
23	WC-37266	KIT, TANK OVERFLOW FITTING INCLUDES BUSHING
24	WC-5502-01*	KIT, PROBE, ASSY WTR LEVEL W/FITTING, O-RING & NUT
25	WC-37317	KIT, STRAIGHT FITTING INCLUDES BUSHING
26	WC-37365	KIT, TANK INLET FITTING INCLUDES BUSHING
27	WC-62033	TANK COMPLETE, GEM W/ULTEM FITTINGS
28	WC-4382	SHOCK GUARD, HEATING ELEMENT
29	WC-43055	SHOCK GUARD, THERMOSTAT
30	WC- 934-04*	KIT, ELEMENT HEATING 2.5KW 220V W/JAM NUTS
31	WC-1438-101*	SENSOR, TEMPERATURE TANK
32	WC- 522*	THERMOSTAT, HI LIMIT HEATER CNTRL DPST 277V 40A
33	WC-5231*	COMPOUND SILICONE 5 OZ
34	WC-3765L*	KIT, INLET VALVE REPAIR USE ON WC-847
35	WC-37121*	KIT, DUMP VALVE USE ON WC-821WDR
36	WC-37122*	KIT, DUMP VALVE USE ON WC-820WDR
37	WC-29044	SLEEVE, OVERFLOW ASSY GEN USE
38	WC-5350	TUBE, SILICONE Ø½" ID x Ø¾" OD x ½" WALL
39	WC-53045	TUBE ASSY, NYLON BRAIDED ¼" FLARE x 28 ½" L
40	WC-43134	O'RING, .426 X 9/16 O.D X .070 WALL EDPM TCTS
41	WC- 810-103	VALVE, CHECK 3/8 X 3/8 BARB SS WITH O-RING & SPRING
42	GEM-6	FILTER, 500/PKG FOR COFFEE BREWCONE WC-3417
42A	GEM-6-101	FILTER, PAPER 15x5½x4¼ FOR TEA BREWCONE WC-3398

* Recommended parts to stock

Electrical Schematic

Combo Brewer

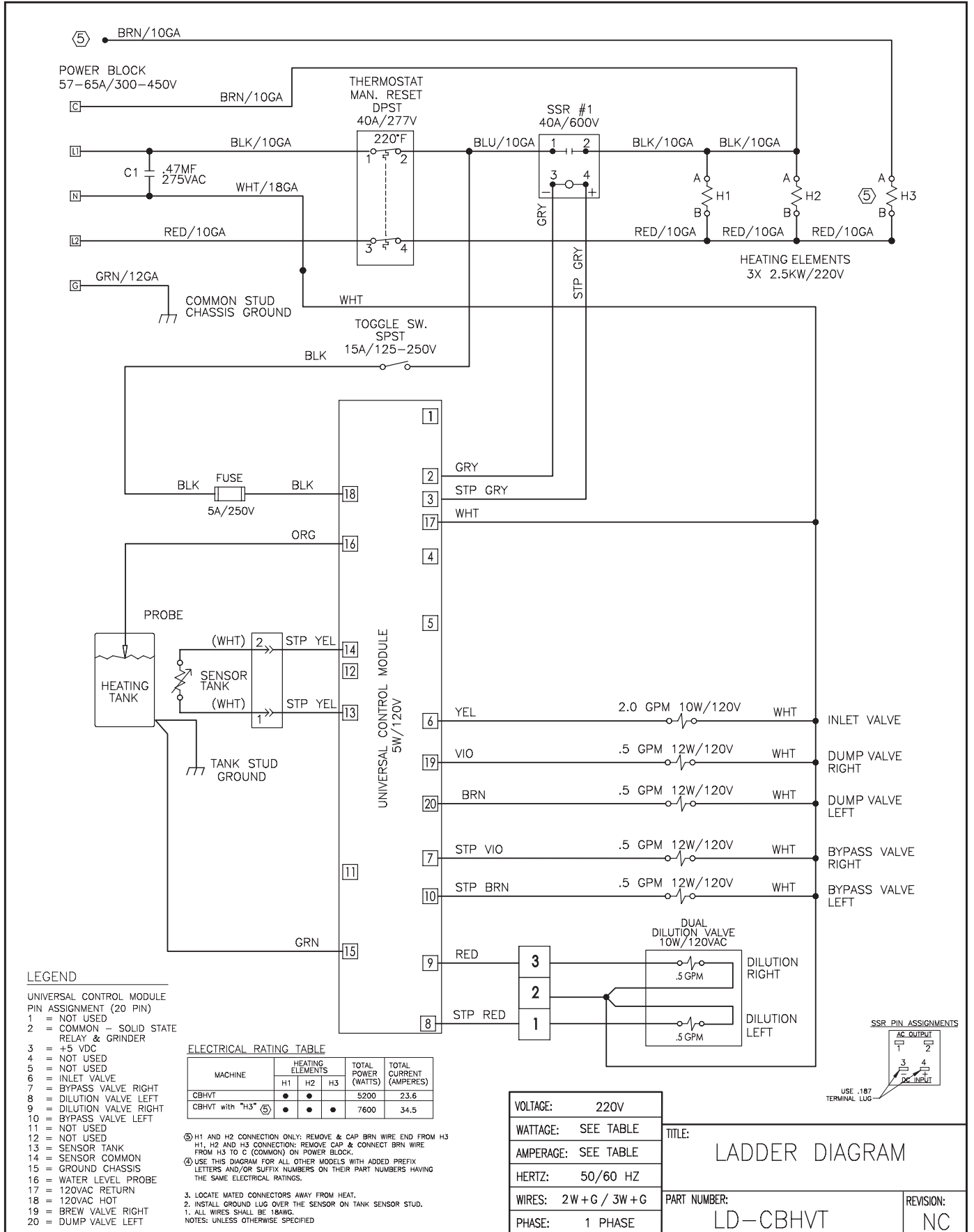

Rough-In Drawing

Curtis High Volume Combo Coffee & Tea Brewer

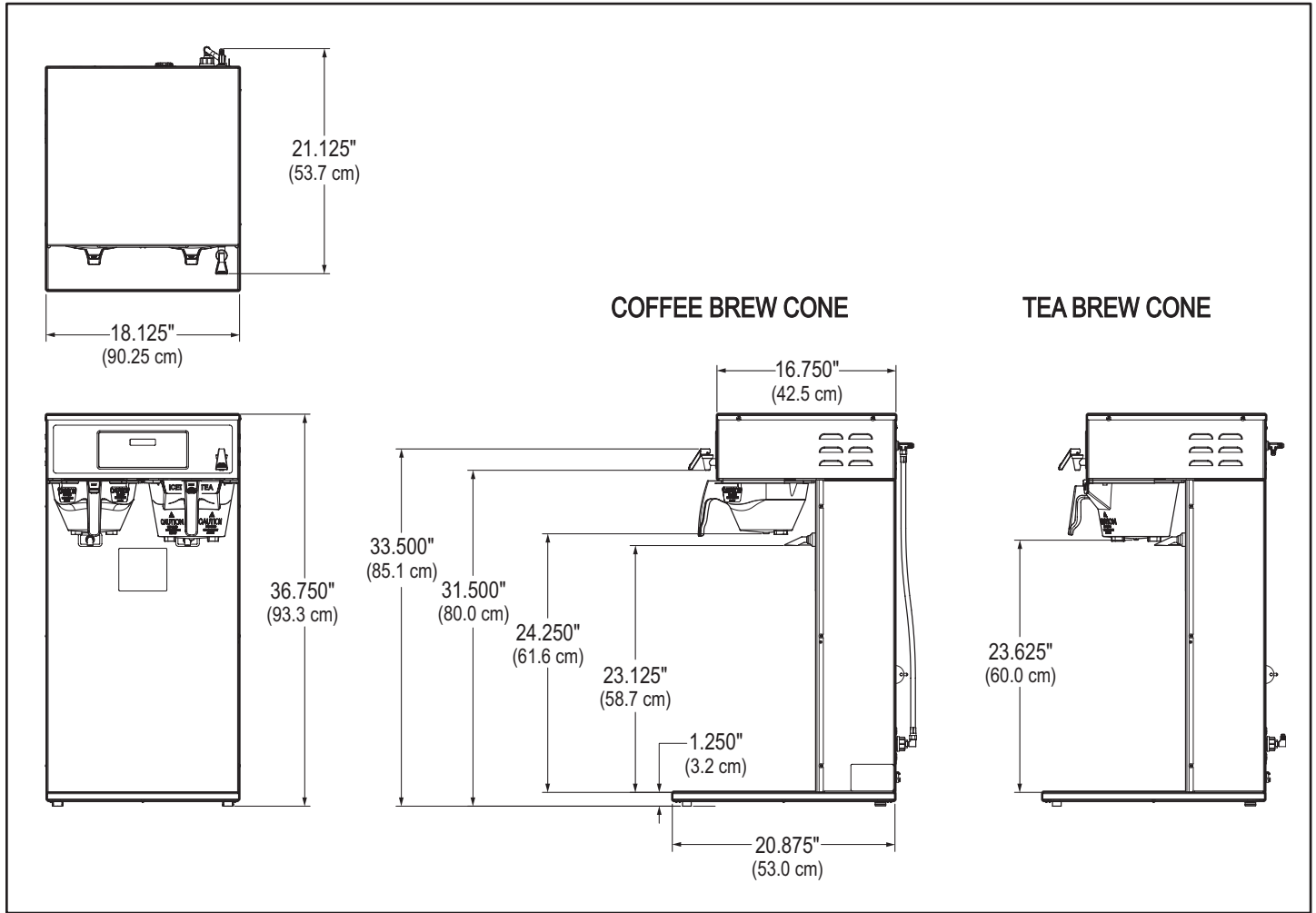

Cleaning The Brewer



CAUTION: DO NOT use undiluted bleach or chlorine.



CAUTION: Never remove faucet when container is full. Drain container first.

DAILY

1. Wipe any spills, dust or debris from the exterior surfaces with a damp cloth. The outside surfaces of the brewer should be cleaned with stainless steel polish only, to prevent scratches.
2. Clean the sprayhead and domed area around the sprayhead with a mild detergent and warm water solution. Scrub well to remove residue. Rinse with and clear water. Dry with clean cloth.
3. Remove the plastic brewcone and wash with a detergent solution or put through a dishwasher.
4. Wash the beverage container.
 - A. Clean container and top cover with a detergent solution.
 - B. Remove the faucet assembly. Unscrew the handle assembly from the faucet and remove. Clean the faucet shank with a gauge glass brush (circular bristle) by pushing the brush through the shank.
 - C. Unscrew the bonnet assembly from the faucet. Brush clean the faucet body inlet and outlet. Clean the faucet cap and silicone seat cup. Dry and assemble parts.

Sweet Tea Mixing System Cleaning & Sanitizing

WEEKLY CLEANING & SANITIZING

Use a concentrated cleaning solution to simplify the cleaning procedure. This procedure requires a one gallon bucket of a cleaning solution of hot water and a granulated concentrated cleaner (a cleaner like Coffee Dispenser Cleaner Corporation #12580, Urnex or equivalent) and a one gallon bucket of clean hot water.

1. Make sure brewer is on and water supply is hooked up.
2. Remove the quick disconnect from the tea sweetener bag-in-box product.
3. Pull the cap off of the QCD and place this end of the line into the container containing the cleaning solution (see illustration below).
4. Place an empty tea container on the brew deck and an empty brewcone into the rails below the sprayhead.
5. Press the SWEET TEA brew button to run one complete brewcycle.
6. Allow the brewer to sit overnight with the cleaning solution in the sweetener line before flushing cleaning solution.
7. Flush the system by filling a one gallon container with clean hot water (no cleaning solution) and press the SWEET TEA brew button to run a brewcycle until all the cleaning solution has been flushed from the system.
8. Discard solution that poured into the container.
9. Remove the QCD from the flushing container and replace the cap. Reconnect the QCD to the Bag in the Box sweetener.
10. If desired, reset Tea Fast Brew to OFF. The unit is ready to resume brewing.

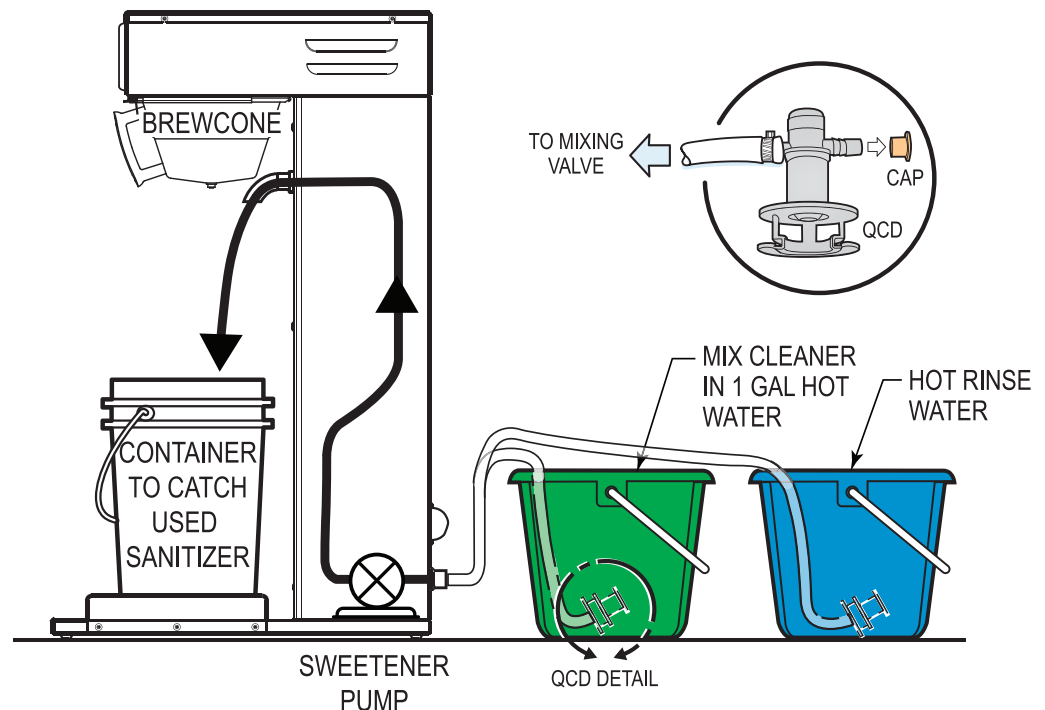

Product Warranty Information

The Wilbur Curtis Company certifies that its products are free from defects in material and workmanship under normal use. The following limited warranties and conditions apply:

- 3 Years, Parts and Labor, from Original Date of Purchase on digital control boards.
- 2 Years, Parts, from Original Date of Purchase on all other electrical components, fittings and tubing.
- 1 Year, Labor, from Original Date of Purchase on all electrical components, fittings and tubing.

Additionally, the Wilbur Curtis Company warrants its Grinding Burrs for Forty (40) months from date of purchase or 40,000 pounds of coffee, whichever comes first. Stainless Steel components are warranted for two (2) years from date of purchase against leaking or pitting and replacement parts are warranted for ninety (90) days from date of purchase or for the remainder of the limited warranty period of the equipment in which the component is installed.

All in-warranty service calls must have prior authorization. For Authorization, call the Technical Support Department at 1-800-995-0417. Effective date of this policy is April 1, 2003.

Additional conditions may apply. Go to www.wilburcurtis.com to view the full product warranty information.

CONDITIONS & EXCEPTIONS

The warranty covers original equipment at time of purchase only. The Wilbur Curtis Company, Inc., assumes no responsibility for substitute replacement parts installed on Curtis equipment that have not been purchased from the Wilbur Curtis Company, Inc. The Wilbur Curtis Company will not accept any responsibility if the following conditions are not met. The warranty does not cover and is void under the following circumstances:

- 1) **Improper operation of equipment:** *The equipment must be used for its designed and intended purpose and function.*
- 2) **Improper installation of equipment:** *This equipment must be installed by a professional technician and must comply with all local electrical, mechanical and plumbing codes.*
- 3) **Improper voltage:** *Equipment must be installed at the voltage stated on the serial plate supplied with this equipment.*
- 4) **Improper water supply:** *This includes, but is not limited to, excessive or low water pressure, and inadequate or fluctuating water flow rate.*
- 5) **Adjustments and cleaning:** *The resetting of safety thermostats and circuit breakers, programming and temperature adjustments are the responsibility of the equipment owner. The owner is responsible for proper cleaning and regular maintenance of this equipment.*
- 6) **Damaged in transit:** *Equipment damaged in transit is the responsibility of the freight company and a claim should be made with the carrier.*
- 7) **Abuse or neglect (including failure to periodically clean or remove lime accumulations):** *Manufacturer is not responsible for variation in equipment operation due to excessive lime or local water conditions. The equipment must be maintained according to the manufacturer's recommendations.*
- 8) **Replacement of items subject to normal use and wear:** *This shall include, but is not limited to, light bulbs, shear disks, "O" rings, gaskets, silicone tube, canister assemblies, whipper chambers and plates, mixing bowls, agitation assemblies and whipper propellers.*
- 9) **Repairs and/or Replacements** *are subject to our decision that the workmanship or parts were faulty and the defects showed up under normal use. All labor shall be performed during regular working hours. Overtime charges are the responsibility of the owner. Charges incurred by delays, waiting time, or operating restrictions that hinder the service technician's ability to perform service is the responsibility of the owner of the equipment. This includes institutional and correctional facilities. The Wilbur Curtis Company will allow up to 100 miles, round trip, per in-warranty service call.*

RETURN MERCHANDISE AUTHORIZATION: *All claims under this warranty must be submitted to the Wilbur Curtis Company Technical Support Department prior to performing any repair work or return of this equipment to the factory. All returned equipment must be repackaged properly in the original carton. No units will be accepted if they are damaged in transit due to improper packaging. **NO UNITS OR PARTS WILL BE ACCEPTED WITHOUT A RETURN MERCHANDISE AUTHORIZATION (RMA). RMA NUMBER MUST BE MARKED ON THE CARTON OR SHIPPING LABEL.** All in-warranty service calls must be performed by an authorized service agent. Call the Wilbur Curtis Technical Support Department to find an agent near you.*

RevB . EAR 10850 . ECN 14366 . 8/23/12@12.9



WILBUR CURTIS CO., INC.

6913 Acco St., Montebello, CA 90640-5403 USA

Phone: 800/421-6150 ♦ Fax: 323-837-2410

♦ Technical Support Phone: 800/995-0417 (M-F 5:30A - 4:00P PST) ♦ E-Mail: techsupport@wilburcurtis.com

♦ Web Site: www.wilburcurtis.com