



Service Manual – G4 Gemini Twin Coffee Brewer

Important Safeguards/Symbols

This equipment is designed for commercial use. Any servicing other than cleaning and routine maintenance should be performed by an authorized Wilbur Curtis Company Service Technician.

- DO NOT immerse the unit in water or any other liquid
- To reduce the risk of fire or electric shock, DO NOT open service panels. There are no user serviceable parts inside.
- Keep hands and other items away from hot areas of the unit during operation.
- Never clean with scouring powders or harsh chemicals.

Symbols:



WARNINGS – To help avoid personal injury



Important Notes/Cautions – from the factory



Sanitation Requirements

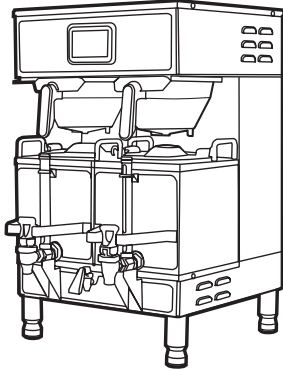

Model
• G4GEMT



CAUTION: Please use this setup procedure before attempting to use this brewer. Failure to follow the instructions can result in injury or the voiding of the warranty.



IMPORTANT: Equipment to be installed to comply with applicable governmental plumbing/electrical codes having jurisdiction.



CAUTION: DO NOT connect this brewer to hot water. The inlet valve is not rated for hot water.

This Curtis Generation 4 Unit is Factory Pre-Set and Ready to Go Right from the Box.

Following are the Factory Settings for your G4 Coffee Brewing System:

- Brew Temperature = 200°F
- Water Bypass = On for LARGE & MEDIUM Brew Only
- Brew Volume = Set to Vessel Requirement.

System Requirements:

- Water Source 20 – 90 PSI (Minimum Flow Rate of 1 GPM)
- Electrical: See attached schematic for standard model or visit www.wilburcurtis.com for your model.

SETUP STEPS

1. The unit should be level (left to right - front to back), on a secure surface.
2. Connect the water line to the water inlet fitting on the rear of the unit. Water volume flow to the machine should be consistent. Use tubing sized sufficiently to provide a minimum flow rate of one gallon per minute.



NOTE: A water filtration system must be used to help maintain trouble-free operation. In areas with extremely hard water, we highly recommend the use of a Curtis approved water filter. For our full line of filters, please log on to www.wilburcurtis.com. A water filtration system will greatly prolong the life of the unit and enhance the quality and taste of the product.



NSF International requires the following water connection:

1. A quick disconnect or additional coiled tubing (at least 2x the depth of the unit) is required so that the unit can be moved for cleaning.
2. This unit must be installed with adequate backflow protection to comply with applicable federal, state and local codes.
3. Water pipe connections and fixtures directly connected to a portable water supply shall be sized, installed and maintained in accordance with federal, state, and local codes.

3. Connect the unit to electrical outlet with appropriate amperage rating (see serial tag on machine).
4. Once power has been supplied to the unit, flip the toggle switch to the 'ON' position (located on the rear of the unit), the water tank will begin to fill. When the water level in the tank reaches the probe, the heating element(s) will turn on.
5. Water in the heating tank will require approximately a half hour before reaching operating temperature (factory setting of 200°F). Where applicable, turn on the Universal Control Module (UCM). When the unit reaches operating temperature, it will display "READY TO BREW".

ISO 9001:2008 REGISTERED

WILBUR CURTIS CO., INC.
6913 West Acco Street
Montebello, CA 90640-5403
For the latest information go to
www.wilburcurtis.com
Tel: 800-421-6150
Fax: 323-837-2410

For the latest specifications and information go to www.wilburcurtis.com
Technical Support: 1-800-995-0417 M-F 5:30am-4:00pm PT

Email: techsupport@wilburcurtis.com

QUICK START

Your Curtis G4/Gold Cup Series is Factory Pre-Set for Optimum Performance.

After connection to water and power; turn on the brewer at the rear toggle switch. You will hear a beep and the status lights will come on for a moment.

The screen will display MODEL NUMBER
CONTROL BD NUMBER. Next FILLING is displayed. Water will fill the tank (2-3 minutes depending on water flow rate).

When the proper level is reached HEATING will appear on the screen. It takes approximately 30 minutes to reach the set point temperature.

Control will display READY TO BREW when temperature reaches the set point. The unit is now ready to brew.

COFFEE BREWING INSTRUCTIONS

1. Brewer should be ON (Confirm at the rear toggle switch). The LCD screen should read Ready to Brew.
2. Place an empty satellite server on the warmer deck, under the brewcone and touch the warmer icon to Preheat the satellite.

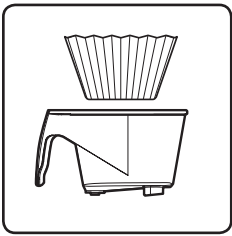

3. Place a clean filter into the brewcone.

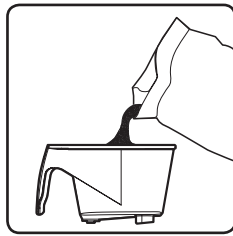

4. Fill brewcone with ground coffee.

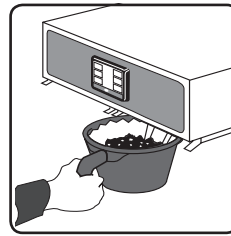

5. Transfer filled brewcone to brewer.

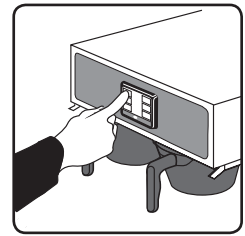

6. Touch desired brew button. Brewing will begin immediately.



WARNING TO AVOID SCALDING, Do not remove brewcone while brew light is flashing.

Touch Screen Control Module

The touch screen turns on when power is available to the controller. The screen will contain standard control feature such as symbols and buttons. Pressing these elements with your finger tip will activate the programming functions. The default screen, as well as some added control buttons are shown in the illustration below.

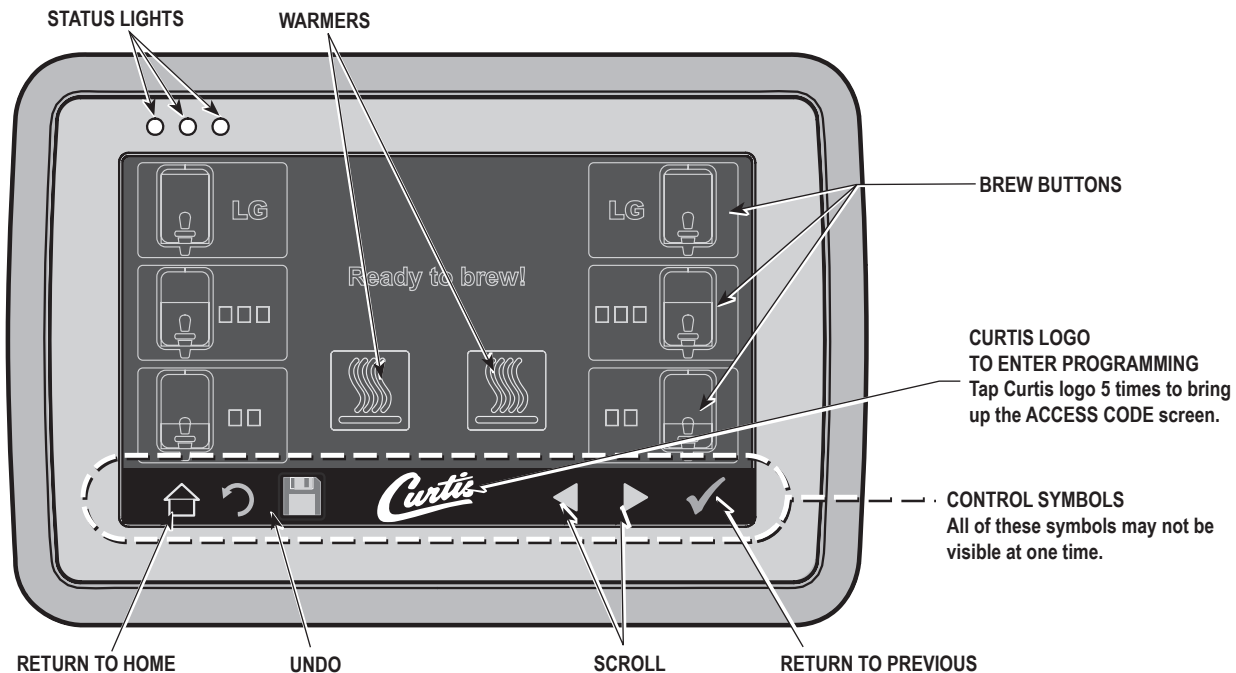

PROGRAMMING

ACCESS CODE
screen. Default is 1 2 3 4. Once the code is entered, press OK. The Main Menu screen will appear.

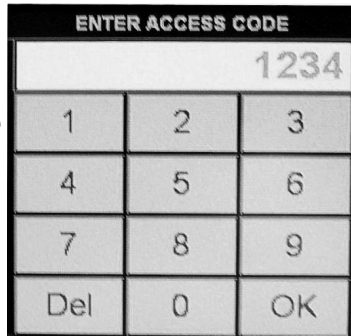

MAIN MENU screen contains five control icons: RECIPES, CONTROL SETTINGS, BREW SETTINGS, MODEL SELECT and EXIT.



Menu Tree

This chart explains how to enter the program mode and menu selections available from the MAIN MENU.

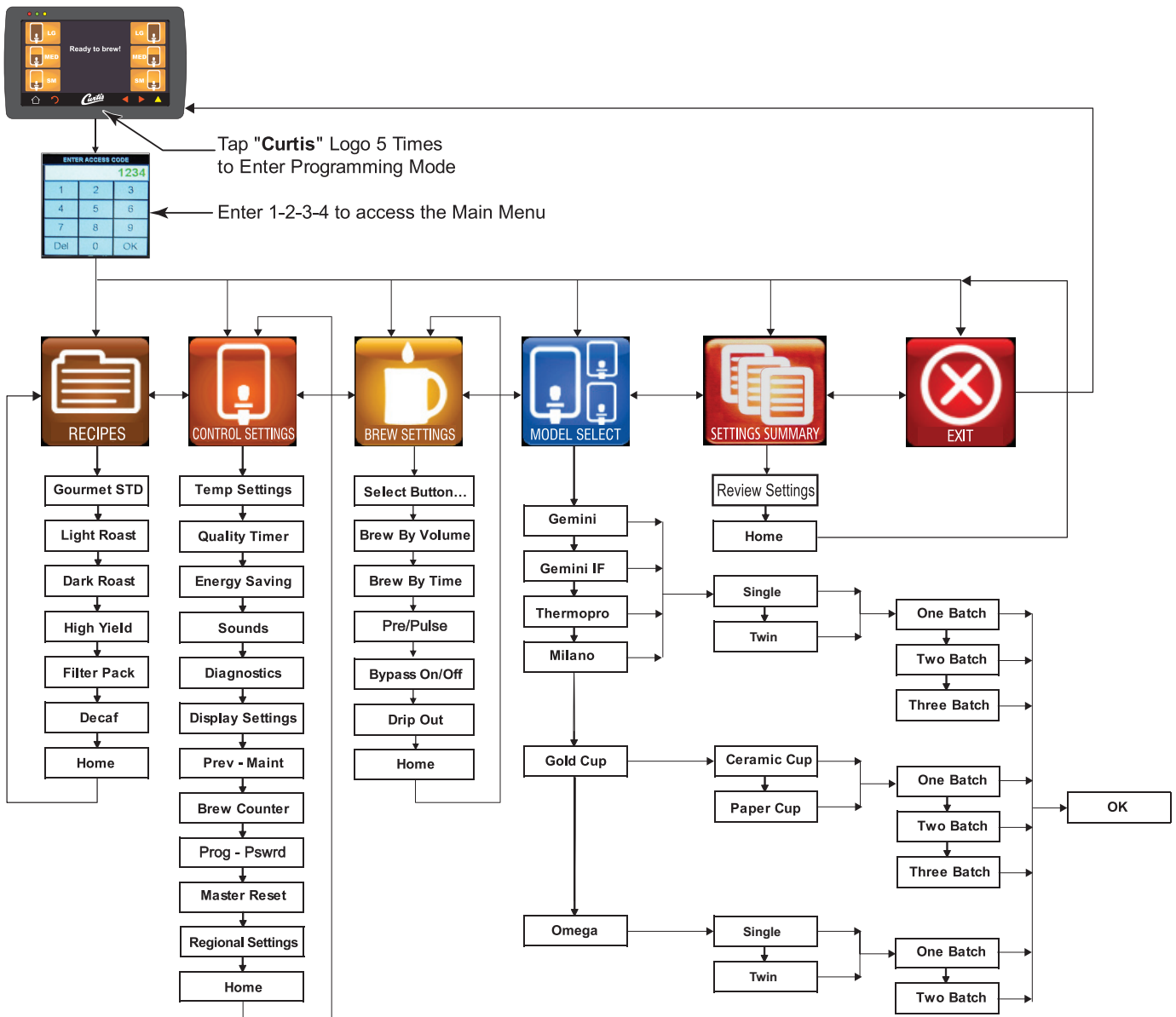

Menu Features Recipes

FUNCTION TO SET	SETTING RANGE	FACTORY SET DEFAULT	NOTES / COMMENTS
Global Recipes	Gourmet STD, Light Roast, Dark Roast, High Yield, Filter Pack, Decaf, Home	Gourmet STD	

Control Settings

FUNCTION TO SET	SETTING RANGE	FACTORY SET DEFAULT	NOTES / COMMENTS
Temperature Settings	175°F - 206°F , 1°F Increments	Tank Temp = 200°F Minimum Brew Temp = 195°F	
Warmer Settings	Disabled, 1 Hr - 12 Hr, 1 Hr Increments.	<Disabled on GEMTS/GEMSS>	Note: This function is only visible on Gemini Units.
	1 Hr - 12 Hr, 1 Hr Increments.	<10 Hr. on GEMTIF/GEMSIF>	
	<OFF>, <HIGH>, <MED.>, <LOW>	<MED.> During Brewing	
Quality Timer	OFF, 20min - 240min, 10 Minute Increments.	<OFF on GEMTS/GEMSS> <120min on GEMTIF/GEMSIF> <OFF on OMEGA>	Audible alarm when time is expired. (Only shows available when a machine has Warmer Elements). (Also this function is visible when Gemini models are selected).
Energy Save Mode (Activates after 4 Hours of Inactivity)	No Change	No Change	Tank temperature is maintained at the temp setpoint default
	Turn Tank Heater Off		Tank is turned off.
	Reduce tank temp to: 140°F		Tank temperature maintained at 140F.
Sounds	Beeper On/Off	On	Turns Board sounds Off or On
Diagnostics	-	Auto Test	Runs Diagnostic Tests
Display Settings	Show Brew Timer	On	Displays Brew Time
	Icon	Original	Square Blue or Original
	Show Quality Timer	Off	Displays Quality Timer
	Screen Saver	Off	Displays Screen Saver
	Display Name	Blank	Displays Banner Name
Prev. Maintenance	Maintenance Interval	Off	Off, 1000 to 20000 Gallons, 1000 Increments
	Service Telephone Number	1-800-000-0000 x0000	
Brew Counter	Resetable	Resetable	For maintenance purpose (Resetable)
Passwords	Resetable	1234	Not Resetable
Master Reset	Reset	Are you sure? (Yes / No)	Select to Reset to Restore Factory Defaults
Regional Settings	SI/US	US	US Units or Metric Units
Home	-	-	Select to go to Home Page

Menu Features

Brew Settings

FUNCTION TO SET	SETTING RANGE	FACTORY SET DEFAULT	NOTES / COMMENTS
Brew by Volume	OFF, 30sec to 19Min.59sec.	LARGE BREW: 200oz ± 8oz using a Amber AFS Sprayhead	To Set: Press Brew to start / Press Brew to stop.
		MEDIUM BREW: 132oz ± 4oz using a Amber AFS Sprayhead	
		SMALL BREW: 64oz ± 4oz using a Amber AFS Sprayhead	
Brew by Time	0 to 19Min - 59sec, 1min-01secs increments	LARGE BREW: 5min 25secs using a Amber AFS Sprayhead	Note: These are the default times for a Amber AFS Sprayhead.
		MEDIUM BREW: 3min 32secs using a Amber AFS Sprayhead	
		SMALL BREW: 1min 52secs using a Amber AFS Sprayhead	
Pre-Infusion	Disabled	Disabled	OFF
	10 secs On/10 secs Off		When this is Chosen "COLD BREW LOCK set to 5°F, Pulse Brew On/Off" Function <Disabled>
	20 secs On/20 secs Off		When this is Chosen "COLD BREW LOCK set to 5°F, Pulse Brew On/Off" Function <Disabled>
	30 secs On/30 secs Off		When this is Chosen "COLD BREW LOCK set to 5°F, Pulse Brew On/Off" Function <Disabled>
	40 secs On/40 secs Off		When this is Chosen "COLD BREW LOCK set to 5°F, Pulse Brew On/Off" Function <Disabled>
	50 secs On/50 secs Off		When this is Chosen "COLD BREW LOCK set to 5°F, Pulse Brew On/Off" Function <Disabled>
	60 secs On/60 secs Off		When this is Chosen "COLD BREW LOCK set to 5°F, Pulse Brew On/Off" Function <Disabled>
Pulse Brew On/Off	OFF	C	OFF
	A		A = "10 seconds ON 4 Times"/"10 seconds OFF 4 Times", then "ON" Till End of Brew Cycle.
	B		B = "1 Minute ON", "10 seconds OFF 4 Times"/10 seconds ON 4 Times", Till end of Brew Cycle.
	C		C = "25 seconds ON 5 Times"/"20 seconds OFF 5 Times", then "ON" Till End of Brew Cycle.
	D		D = Manual Program: "PULSE COUNT = 1 to 20 pulses", "ON TIME = 5 - 150 seconds", "OFF TIME = 5 - 150 seconds", 5 second increments.
	E		E = Manual Program: "PULSE COUNT = 1 to 12 pulses", "ON TIME = 0 - 150 seconds", "OFF TIME = 1 - 150 seconds", 1 second increments.
By-Pass On/Off	Off, 5%-50%, in 5% increments	LARGE BREW: 35% using a Amber AFS Sprayhead	Note: These are the default times for a Amber AFS Sprayhead
		MEDIUM BREW: 10% using a Amber AFS Sprayhead	
		SMALL BREW: Off using a Amber AFS Sprayhead	
Drip-Out Mode	Off, 5 Seconds - 15min, 10 Second Increments	2 min	Reprogrammable
Home	-	-	Select to go to Home Page

System Fault Messages

WARNING MESSAGES - ALLOWS BREWING

MESSAGE DISPLAY	WARNING DESCRIPTION	CAUSE
Component Failure	A Component has Failed	Current in the valves or heaters is out of range
Maintenance Required	Maintenance Required	Brew count "Gallons Since Reset" exceeds programmed Preventative Maintenance period
SCALE WARNING SERVICE REQUIRED*	Scale Starting to Build Up Water Level Probe	Water level probe resistance above warning threshold (test value 22kOhm - 100kOhm). Still allows brewing.
Low Water Flow Warning*	Low Water Flow	If the Inlet valve remains on longer than XX Seconds (during the brew cycle only) and repeats TWICE during that brew cycle. It shall clear upon the next brew and if the same low flow exists again, it will re-appear. XX = Alpha 20 secs; Gem/TP Twin 40 secs; Gem/TP Single 30 secs

ERROR MESSAGES - STOPS BREWING

MESSAGE DISPLAY	ERROR DESCRIPTION	CAUSE
Water Level Error	Fill run error / Overflow	The fill solenoid has either run for more than 10 minutes on the initial tank fill or 120 Seconds on Large Brewers and 30 Seconds on CGC Brewer in normal operation
Sensor Error	Open Sensor	Break in the temperature thermistor circuit or short circuit.
Over Temp. Error	Excess Temperature	The sensor is reading that temperature in the heating tank has risen above 210°F, or sensor has shorted to ground.
SCALE ERROR SERVICE REQUIRED*	Scale Build up on Water Level Probe	Water level probe resistance above error threshold (test value 100kOhm & Above) (Above 100kOhm reading must remain for 4 Mins. In order for Error to be triggered)
Internal Error 1	UPM-UCM Communication	Break in the UPM-UCM Communication circuit.

* These Messages will be available in subsequent software revisions.

Illustrated Parts Main View

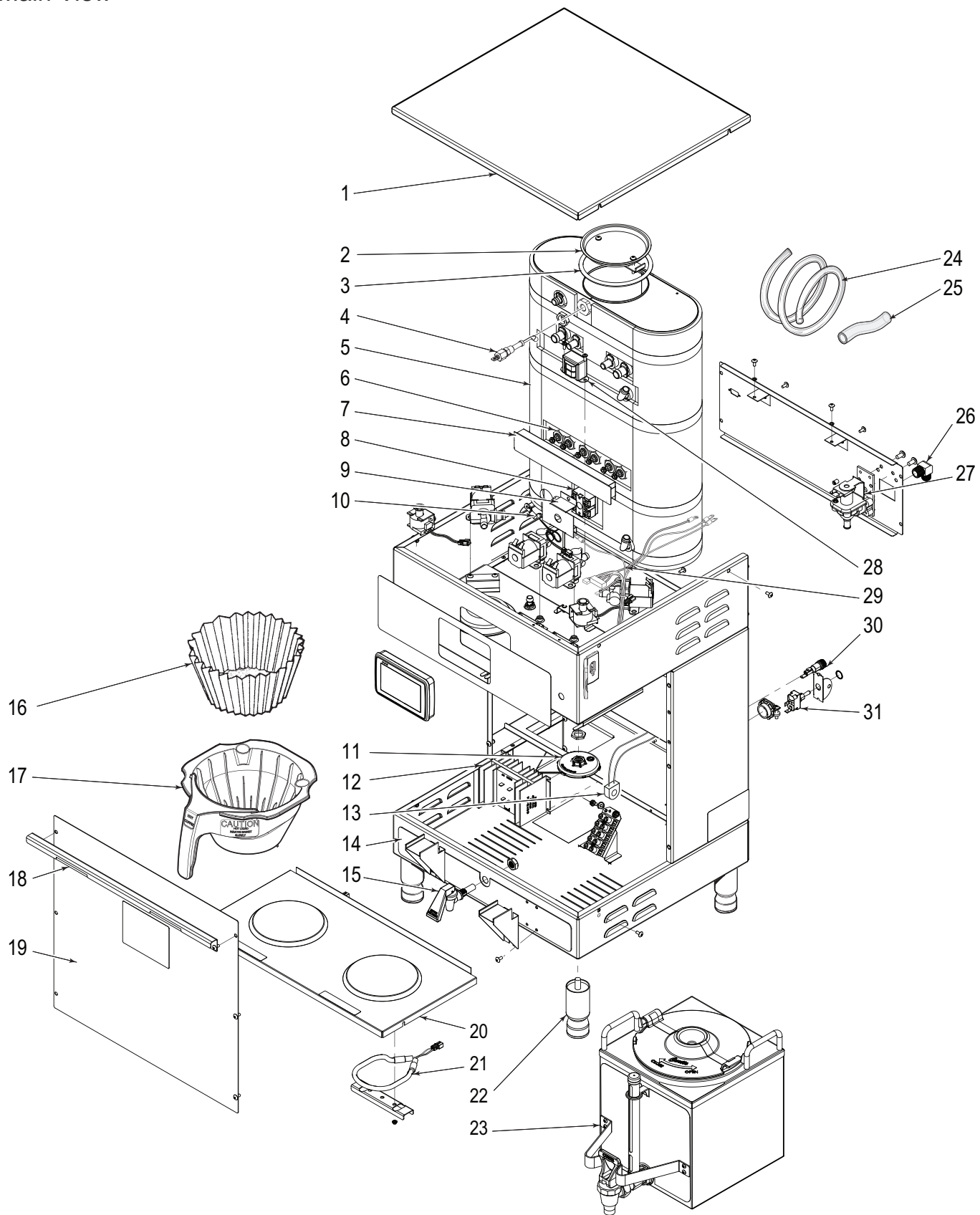

Illustrated Parts

Top Wrap

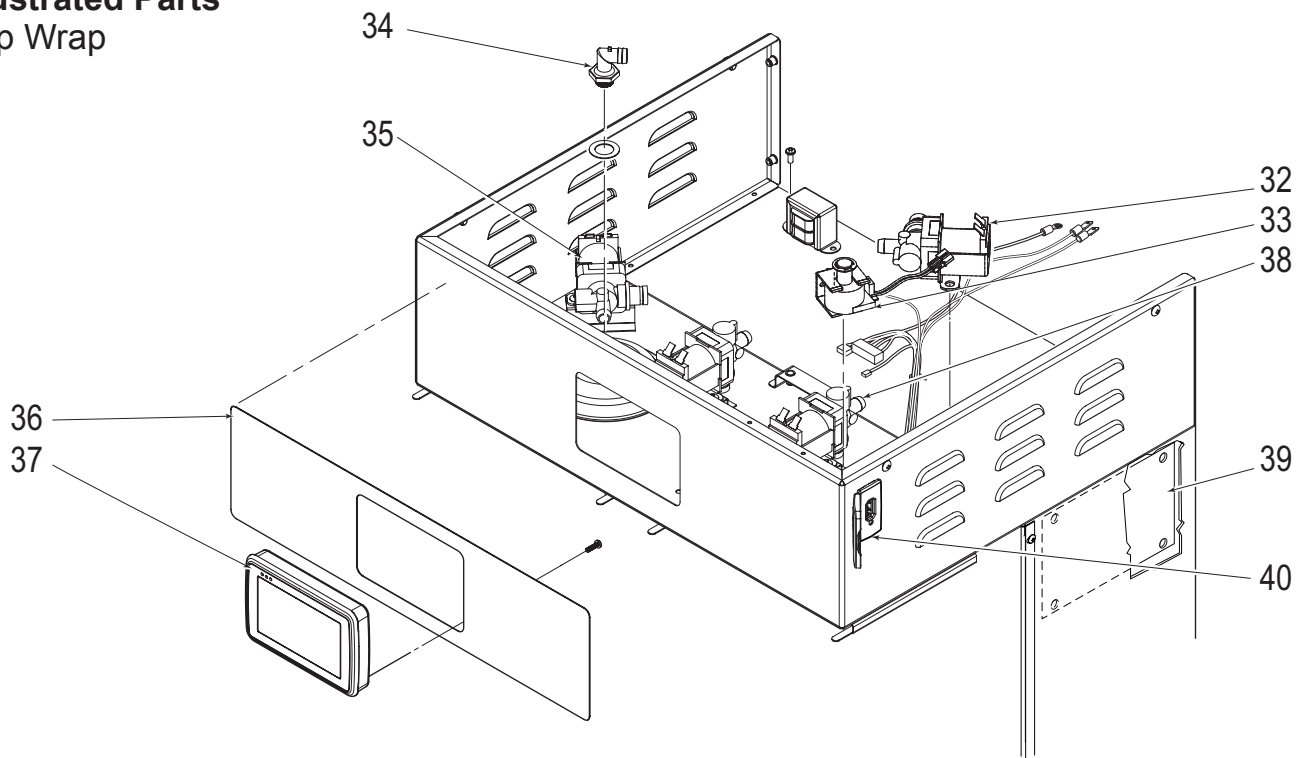

ITEM NO.	PART NO.	DESCRIPTION
1	WC-5421-BLK	COVER, TOP - PAINTED BLACK TEXTURE PC
1A	WC-5421	COVER, TOP STAINLESS GEMTIF
2	WC-37008	KIT, TANK LID ROUND
3	WC-43067*	O-RING, 4-1/2 I.D. x Ø.285 C.S. SILICONE
4	WC-5502-01*	KIT, PROBE, ASSY WATER LEVEL W/HEX FITTING, O-RING & NUT
5	WC-62033	TANK COMPLETE, GEMTS WITH ULTEM FITTINGS
6	WC- 934-04*	KIT, HEATING ELEMENT 2.5KW 220V W/JAM NUT & SILICONE WASHERS
7	WC-4382*	GUARD, SHOCK - DOUBLE HEATING ELEMENTS
8	WC- 522*	THERMOSTAT, HI LIMIT HEATER DPST 277V-40A
9	WC-43055	GUARD, SHOCK RESET THERMOSTAT
10	WC-1438-101*	SENSOR, TEMPERATURE TANK
11	WC-29050*	SPRAYHEAD ASSY, AFS-AMBER
12	WC-8559*	RELAY, SOLID STATE 40A w/INTEGRATED HEATSINK
13	WC-14045-101	CURRENT SENSOR ASSY G4
14	WC-39745	LABEL, BOTTOM WRAP - GEMTIF
15	WC-1809	FAUCET, PS/HSP SERIES HOT WATER 1/2-20 UNF
16	GEM-6*	FILTER, 500PK GEM-12/230A
17	WC-3417	BREW CONE, ASSY W/SPLASH POCKET BRWN STYLIZED GEMIN HOT COFFEE
18	WC-37310	KIT, BREWCONE ALIGNMENT BRACKET STAINLESS
19	WC-61393	COVER, FRONT W/A GEMTS
20	WC-5423	DECK, WARMER W/ASSY GEM12/312IL/612IL/12ILD/612ILD
21	WC-37102*	KIT, WARMER ELEMENT
22	WC-3528	LEG, 4" ADJUSTABLE 3/8-16 THRD STYLIZED
23	GEM-3	SATELLITE SERVER, 1-1/2 GAL.
24	WC-5310*	TUBE, 5/16 ID x 1/8W SILICONE
25	WC-5350*	TUBE, SILICONE Ø1/2" ID x Ø3/4" OD x 1/8" WALL

* RECOMMENDED PARTS TO STOCK

Parts List

ITEM NO.	PART NO.	DESCRIPTION
26	WC-2402P	ELBOW, 3/8 NPT x 3/8 FLARE PLATED
27	WC- 847*	VALVE, INLET 2 GPM 120V-10W
28	WC- 589-101	TRANSFORMER, 120/230VAC - 24VAC 4.8VA w/LEADS & TERMINALS
29	WC-13450	HARNESS ASSY, COMPLETE TP2T10G4/GEMTS10G4/GEMTIF10G4
30	WC-1501	FUSE, HOLDER ASSY w/5A FUSE
31	WC- 102 *	SWITCH, TOGGLE SPST 15A 125Vac RESISTIVE
32	WC-37121	KIT, DUMP VALVE LEFT
33	WC- 442 *	SOLENOID, LOCK BREW CONE RIGHT 120VAC
34	WC-2977-101K	KIT, SPRAYHEAD FITTING, GASKET & JAM NUT
35	WC-37122*	KIT, DUMP VALVE RIGHT
36	WC-39812	LABEL, OUTER TOUCHSCREEN GEMTSG4 CURTIS LOGO
37	WC-10000*	CONTROL MODULE, TOUCH SCREEN G4
38	WC- 844-101*	VALVE, BYPASS 120V-14W NON ADJUSTABLE WITH RESTRICTOR (WC-2945)
39	WC-10001*	UNIVERSAL POWER MODULE - G4
40	WC-10008	UNIVERSAL HOST ADAPTER (USB)

* RECOMMENDED PARTS TO STOCK

Rough-In Drawing

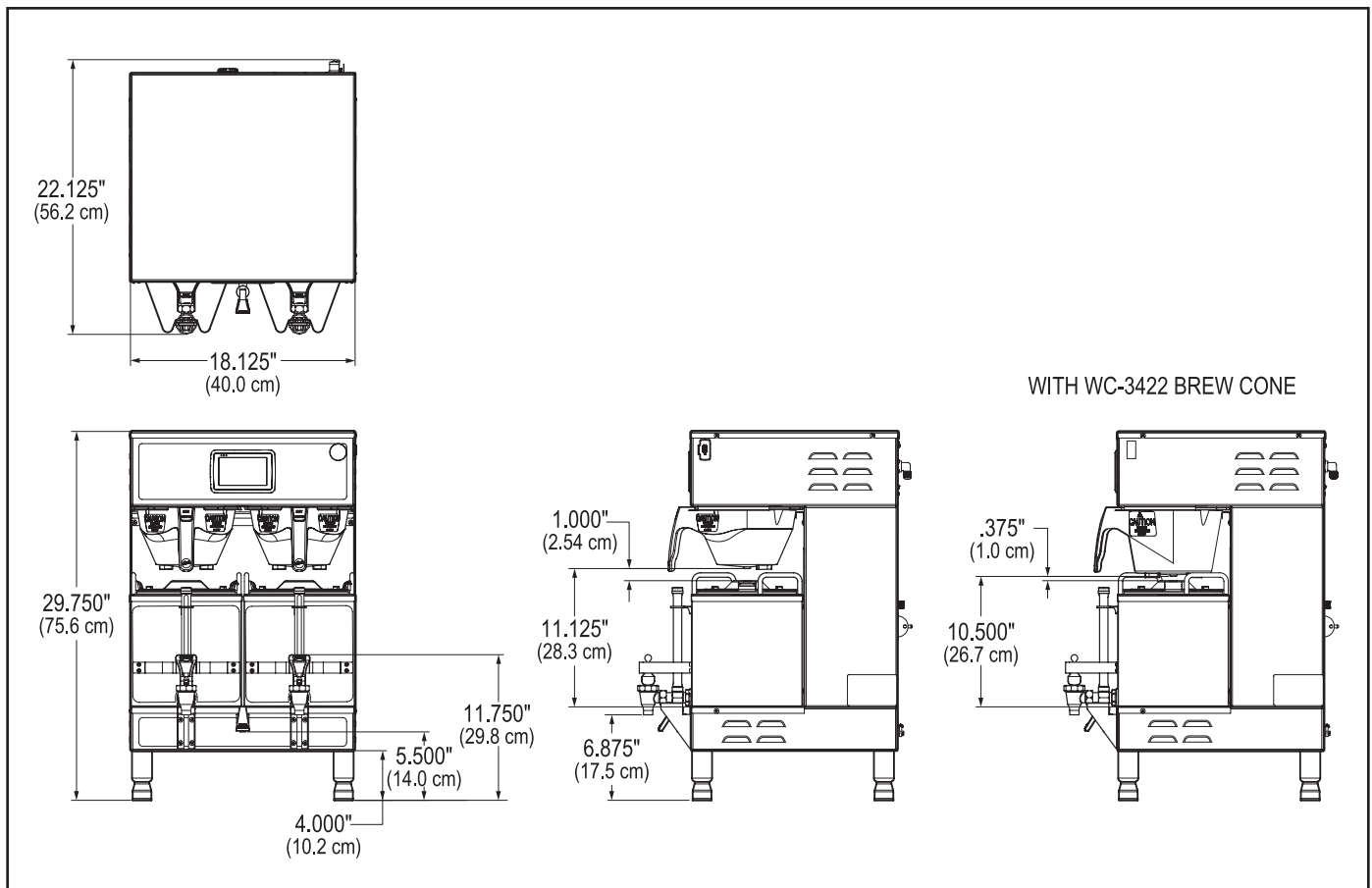

Electrical Schematic

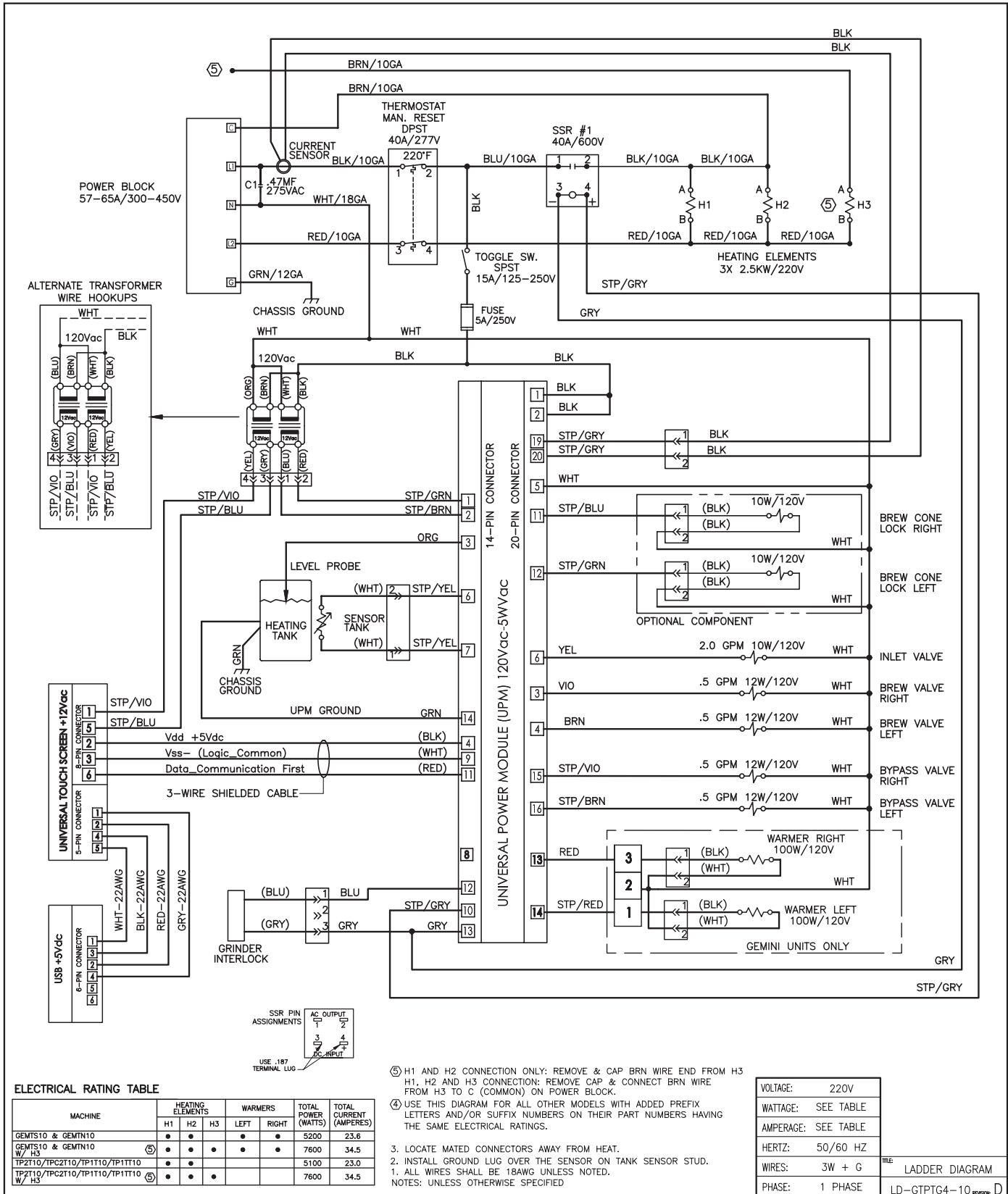

Cleaning the Coffee Brewer

Regular cleaning and preventive maintenance is essential in keeping your coffee brewer looking and working like new.



CAUTION – Do not use cleansers, bleach liquids, powders or any other substance containing chlorine. These products promote corrosion and will pit the stainless steel. USE OF THESE PRODUCTS WILL VOID THE WARRANTY.

1. Wipe exterior surfaces with a moist cloth, removing spills and debris.
2. Slide the brewcone out and clean it. Clean the sprayhead area with a moist clean cloth.
3. Rinse and dry the brewcone.
4. Drain drip tray of coffee. Wash out the drip tray. Dry the tray.
5. Rub a stainless steel polish on the outside surfaces to protect the brewer.

Cleaning the Satellite Server

To clean the Satellite components, prepare a mild solution of detergent and warm water..

1. Remove lid from Satellite. Clean the lid at the funnel area with a spiral brush and detergent solution.
2. Rinse the lid, removing all traces of cleaning solution.
3. Unscrew the handle/bonnet assembly and remove it from the dispensing faucet.
4. Pull the silicone seat cup from faucet stem and inspect it for wear, cracks, or hardening. Replace the seat cup if necessary.
5. Clean all parts. Thoroughly rinse with clear warm water.
6. Dry and assemble the handle/bonnet parts. Hand-tighten the assembly onto the faucet.
7. Remove the gauge glass tube by unscrewing the gauge glass cap.
8. Clean the gauge glass tube and the two washers with a gauge brush and detergent solution. Rinse with clear water. Dry the parts and assemble them onto the Satellite.

DO NOT immerse the Satellite in water or any other liquid.

9. Clean inside of the Satellite. Remove coffee residue with the detergent solution.
10. Thoroughly rinse out the Satellite with clear warm water.

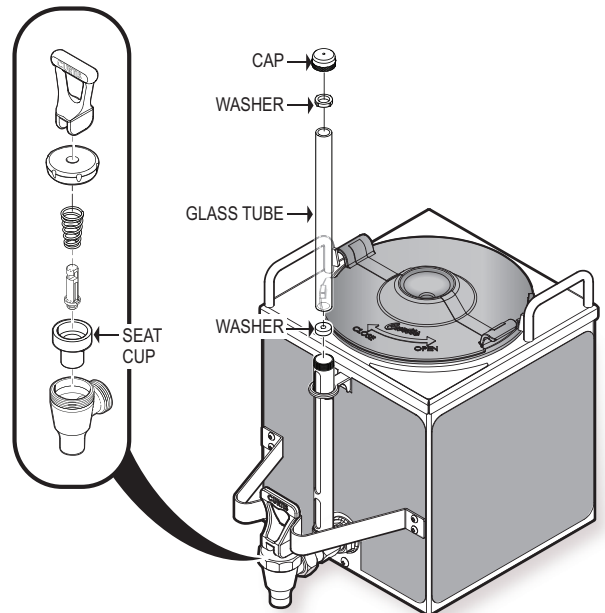

Product Warranty Information

The Wilbur Curtis Company certifies that its products are free from defects in material and workmanship under normal use. The following limited warranties and conditions apply:

- 3 Years, Parts and Labor, from Original Date of Purchase on digital control boards.
- 2 Years, Parts, from Original Date of Purchase on all other electrical components, fittings and tubing.
- 1 Year, Labor, from Original Date of Purchase on all electrical components, fittings and tubing.

Additionally, the Wilbur Curtis Company warrants its Grinding Burrs for Forty (40) months from date of purchase or 40,000 pounds of coffee, whichever comes first. Stainless Steel components are warranted for two (2) years from date of purchase against leaking or pitting and replacement parts are warranted for ninety (90) days from date of purchase or for the remainder of the limited warranty period of the equipment in which the component is installed.

All in-warranty service calls must have prior authorization. For Authorization, call the Technical Support Department at 1-800-995-0417. Effective date of this policy is April 1, 2003.

Additional conditions may apply. Go to www.wilburcurtis.com to view the full product warranty information.

CONDITIONS & EXCEPTIONS

The warranty covers original equipment at time of purchase only. The Wilbur Curtis Company, Inc., assumes no responsibility for substitute replacement parts installed on Curtis equipment that have not been purchased from the Wilbur Curtis Company, Inc. The Wilbur Curtis Company will not accept any responsibility if the following conditions are not met. The warranty does not cover and is void under the following circumstances:

- 1) **Improper operation of equipment:** *The equipment must be used for its designed and intended purpose and function.*
- 2) **Improper installation of equipment:** *This equipment must be installed by a professional technician and must comply with all local electrical, mechanical and plumbing codes.*
- 3) **Improper voltage:** *Equipment must be installed at the voltage stated on the serial plate supplied with this equipment.*
- 4) **Improper water supply:** *This includes, but is not limited to, excessive or low water pressure, and inadequate or fluctuating water flow rate.*
- 5) **Adjustments and cleaning:** *The resetting of safety thermostats and circuit breakers, programming and temperature adjustments are the responsibility of the equipment owner. The owner is responsible for proper cleaning and regular maintenance of this equipment.*
- 6) **Damaged in transit:** *Equipment damaged in transit is the responsibility of the freight company and a claim should be made with the carrier.*
- 7) **Abuse or neglect (including failure to periodically clean or remove lime accumulations):** *Manufacturer is not responsible for variation in equipment operation due to excessive lime or local water conditions. The equipment must be maintained according to the manufacturer's recommendations.*
- 8) **Replacement of items subject to normal use and wear:** *This shall include, but is not limited to, light bulbs, shear disks, "O" rings, gaskets, silicone tube, canister assemblies, whipper chambers and plates, mixing bowls, agitation assemblies and whipper propellers.*
- 9) **Repairs and/or Replacements** *are subject to our decision that the workmanship or parts were faulty and the defects showed up under normal use. All labor shall be performed during regular working hours. Overtime charges are the responsibility of the owner. Charges incurred by delays, waiting time, or operating restrictions that hinder the service technician's ability to perform service is the responsibility of the owner of the equipment. This includes institutional and correctional facilities. The Wilbur Curtis Company will allow up to 100 miles, round trip, per in-warranty service call.*

RETURN MERCHANDISE AUTHORIZATION: *All claims under this warranty must be submitted to the Wilbur Curtis Company Technical Support Department prior to performing any repair work or return of this equipment to the factory. All returned equipment must be repackaged properly in the original carton. No units will be accepted if they are damaged in transit due to improper packaging. **NO UNITS OR PARTS WILL BE ACCEPTED WITHOUT A RETURN MERCHANDISE AUTHORIZATION (RMA). RMA NUMBER MUST BE MARKED ON THE CARTON OR SHIPPING LABEL.** All in-warranty service calls must be performed by an authorized service agent. Call the Wilbur Curtis Technical Support Department to find an agent near you.*

10/10/12@7.8 . ecn 14475 . ear 10674



WILBUR CURTIS CO., INC.
6913 Acco St., Montebello, CA 90640-5403 USA
Phone: 800/421-6150 ♦ Fax: 323-837-2410
♦ Technical Support Phone: 800/995-0417 (M-F 5:30A - 4:00P PST)
♦ Web Site: www.wilburcurtis.com

♦ E-Mail: techsupport@wilburcurtis.com

10/2012 . F-3804 rev A