

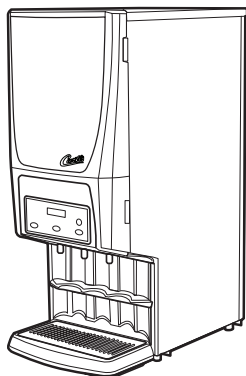

Service Manual – PCGT3



Models Included

- PCGT3 STANDARD
- PCGT3 PRESET DISPENSE
- PCGT3 ICED CAPPUCCINO

**IMPORTANT** CAUTION: Equipment must be installed to comply with applicable federal, state, and local plumbing/ electrical codes having jurisdiction.

**IMPORTANT** CAUTION: Follow this setup procedure before attempting to use this unit. Failure to follow these instructions can result in injury and/or void of warranty.

**IMPORTANT** CAUTION: DO NOT connect the unit to hot water. The inlet valve is not rated for hot water.

ISO 9001:2008 REGISTERED

WILBUR CURTIS CO.  
6913 Acco Street,  
Montebello, CA 90640-5403  
For the latest information go to  
[www.wilburcurtis.com](http://www.wilburcurtis.com)  
Tel: 800/421-6150  
Fax: 323/837-2410



Important Safeguards/Symbols

This appliance is designed for commercial use. Any servicing other than cleaning and routine maintenance should be performed by an authorized Wilbur Curtis Company service technician.

- DO NOT immerse the unit in water or any other liquid
- To reduce the risk of fire or electric shock, DO NOT open service panels. There are no user serviceable parts inside.
- Keep hands and other items away from hot areas of the unit during operation.
- Never clean with scouring powders or harsh chemicals.

Symbols



WARNINGS – To help avoid personal injury



Important Notes/Cautions – from the factory



Sanitation Requirements

Your Curtis G3 System is Factory Pre-Set and Ready to Go, Right from the Box.

Following are the Factory Settings for your Primo Cappuccino Beverage System:

- Tank Temperature = 190°F
- Flavor Controls= Set at 60%
- Dispensing Mode Set for Manual Dispensing

Generally there will never be a reason to change your G3 programming. However, should you need to make slight adjustments to meet your dispensing needs, programming instructions are provided later in this manual.

System Requirements:

- Water Source 20 – 90 PSI (Minimum Flow Rate of 1 GPM)
- Electrical: See electrical schematic on page 7.

SETUP STEPS

1. The unit should be level (left to right - front to back), on a secure surface.
2. Connect the water line to the water inlet fitting on the rear of the unit. Water volume going to the machine should be consistent. Use tubing sized sufficiently to provide a minimum flow rate of one gallon per minute.

*NOTE: Some type of water filtration device must be used to maintain a trouble-free operation. (In areas with extremely hard water, we suggest that a sedimentary and taste & odor filter be installed.) This will prolong the life of your cappuccino system and enhance product taste.*



NSF International requires the following water connection:

1. A quick disconnect or additional coiled tubing (at least 2x the depth of the unit) so that the machine can be moved for cleaning underneath.
2. This equipment is to be installed with adequate backflow protection to comply with applicable federal, state and local codes..
3. Water pipe connections and fixtures directly connected to a potable water supply shall be sized, installed and maintained in accordance with federal, state, and local codes.

3. Plug the power cord into an electrical outlet rated at 20A.
4. Turn on power at the toggle switch behind the unit. The lights (display window and row of buttons) on the front door will activate and the heating tank will start to fill.
5. Water in the heating tank will require about one hour to reach operating temperature (factory setting of 190°F). At this time the LCD will display "READY TO DISPENSE".
6. Remove and fill the canisters with powdered cappuccino product.

## Operation Instructions

1. Choose a flavor. Place your cup under the spout beneath the desired flavor.

**Note:** When using Iced Cappuccino machine, fill your cup with ice before dispensing product.

2. Push and hold the dispensing button for this flavor.
3. Release the button when the cup is  $\frac{3}{4}$  full.

## FILL CANISTERS DAILY

1. Open the front door to access the product canisters.
2. The canisters must be removed from the unit for filling. Turn the powder delivery elbows clockwise, pointing upward. Pull all of the canisters from the canister tray.
3. Refill the canisters. The small canisters hold five pounds of product. Larger canisters hold 10 pounds each. See Configuration of Canisters on page 6.
3. Reposition the canisters on the canister tray. Properly mate the gear socket with the gear on the motor shaft when aligning canisters. Turn the elbows clockwise, pointing downward.

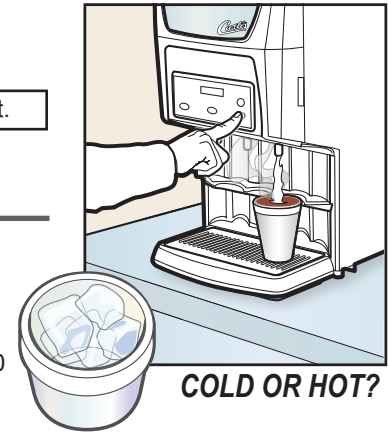

## Cleaning the Curtis Primo Cappuccino GT Beverage Dispenser

**CAUTION - Do not use cleansers, liquid bleach, powders or any other substance containing chlorine. These products promote corrosion and will pit the stainless steel. THE USE OF THESE PRODUCTS WILL VOID YOUR WARRANTY.**

- EVERY 3 - 4 HOURS OR MORE OFTEN IF NECESSARY
  - A. Make sure power is ON.
  - B. Place a container under the dispense spout to catch the rinse water.
  - C. Locate the WASH button on the front control panel.
  - D. Rinse each flavor by pressing and holding the WASH button, while at the same time pressing one of the PUSH dispensing buttons on the control panel.
  - E. Continue holding the WASH button until the water running from the spout runs clear.
- DAILY
  - A. Switch OFF the unit at the power toggle switch, located behind the unit.
  - B. Wipe all exterior surfaces with a damp cloth, removing any spills, residue or dust from the unit.
  - C. Remove both the drip drawer and louvered screen; then wash out its contents. For hard to clean deposits, use a mild, nonabrasive detergent. Rinse with water.
  - D. Wipe and clean the dispensing area with a mild detergent cleaner.
- WEEKLY OR MORE OFTEN IF NECESSARY
  - A. Clean the parts from the whipper assembly.
    1. Remove the dispensing nozzle from the whipper chamber. Clean the inside using a narrow brush.
    2. Remove the upper mixing cup. Pull cup forward, twist to the left and lift it to separate the upper mixing cup from the lower mixing cup.
    3. To remove the lower mixing cup, pull mixing cup up and forward to free it from the hot water inlet fitting.
    4. Remove the whipper chamber. Take hold of the whipper chamber. Turn it clockwise to free it from the mounting plate.
    5. Pull the whipper propeller from the motor shaft.
    6. Wash, Rinse and Sanitize using a 3-sink method. Air dry all parts.
    7. Re-assemble cleaned parts onto the machine.

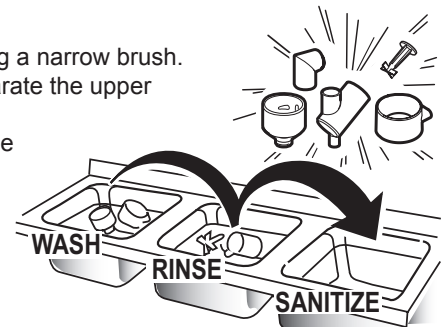

**IMPORTANT - When replacing the propeller, make sure it is properly aligned and seated on the motor shaft. The propeller has an embossed 'D' to properly align it on the motor shaft. Failure to properly seat the propeller will cause it to fuse with the whipper chamber. This condition will not be covered under warranty.**

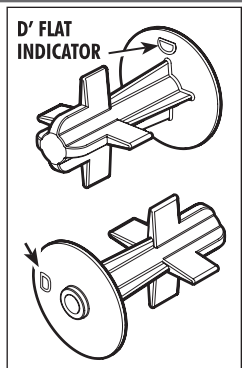

6. Clean the mounting plate.
  - a. Clean the shaft with a cloth and mild detergent before removing mounting plate.
  - b. Twist the mounting plate clockwise and pull it from the motor shaft.

**IMPORTANT - Do not remove pillars to take off mounting plate.**

- c. Clean the area behind the mounting plate.
- d. Clean the water inlet fitting.
- e. Lubricate the center seal of the mounting plate before reinstalling.

## Steps to Programming

Your Curtis Generation 3 cappuccino dispenser is Factory Pre-Set for Optimum Performance. Programming for all models is identical except where noted.

### Entering the Programming Menus

Press and hold STOP/WASH for about ten [10] seconds. Display will read Program Menu, (See Illustration).

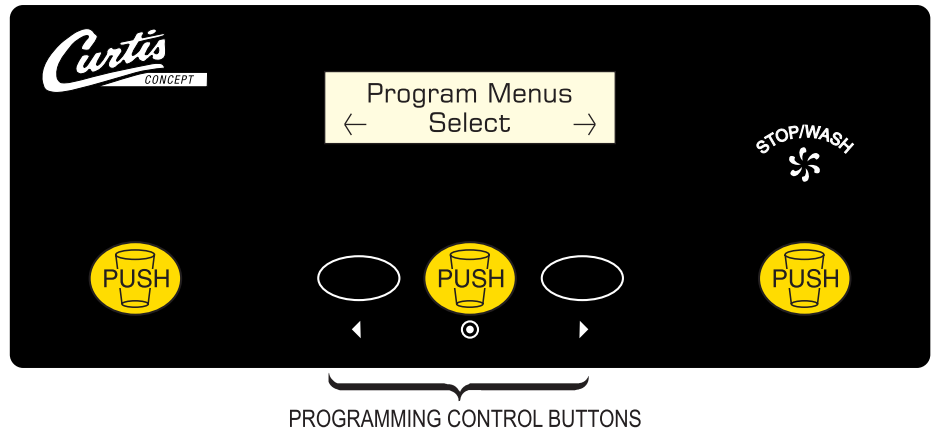

### Manual Dispense (Factory Set to Manual Dispense)

Press  $\odot$  or  $>$  to go to Manual Dispense Select.

Press  $\odot$  to go to Manual Dispense Select Station.

Choose the station and press, the display will read Saving Complete! To select another station for manual dispense, press  $\odot$  to go to Manual Dispense Select Station or press  $>$  to continue to the next menu.

### Dispense By Time (Factory Setting OFF)

The next screen is Dispense By Time  $<$  Select  $>$ . Press  $\odot$  to select a station. Select the station and the screen will read To Begin Press Push. Press desired dispense button. Hot water will start to dispense and screen will display To Finish Press Push. When Push is pressed, time will be saved and you will exit back to Dispense by Time screen. Continue with additional selections or press  $>$  to continue to the next menu.

### Temperature (Factory set at 190°F – Cold Cappuccino Units Set at 96°F)

Press  $\odot$  and screen will show Tank Temperature. Temperature is programmable from 80°F to 204°F in 2-degree increments. Press  $<$  or  $>$  to go up or down in degrees. Select desired temperature and then  $\odot$  to set. Press  $>$  to continue to the next menu.

### Powder % Ratio (Factory set at 60%)

Press  $\odot$  and the screen will display Powder % Ratio Select Station. Press desired station. Powder ratio is programmable from 0% (Hot Water) to 100%, in 5% increments. Press  $<$  or  $>$  to increase or decrease ratio and then press  $\odot$  to set. Press  $>$  to continue to the next menu.



*Valves **should not** be field adjusted to change product strength. Product strength adjustments should be done through programming on the front panel only.*

### Service Call (Factory Set to 1-800-000-0000 x0000)

Press  $\odot$  to display number and press  $\odot$  change number or  $>$  to move places and EX to exit when complete This number will be displayed during a Heating system SENSOR ERROR or a WATER ERROR. Press  $>$  to continue to the next menu.

### Banner Name (Factory Set to Curtis)

Press  $\odot$  to display letters, press  $\odot$  to change letters or  $>$  to move places and EX to exit when complete.

This feature allows up to 14 letters to be programmed for company name or regional name. Programming all blanks disables Banner Name. Press  $>$  to continue to the next menu.

### Model Select

Press  $\odot$  to select,  $<$  or  $>$  to select desired model (PC-3, 4, 5) . Press  $\odot$  to set and exit program mode.

### Exit

Press  $\odot$  to select, exits program mode and returns unit to operation.

# Parts List

Item Nº	Part Nº	Description	Item Nº	Part Nº	Description
1	WC-58110	COVER, TOP PCGT3	30	WC-2626-03	BUSHING, AUGER
2	WC-68123	PANEL, LEFT SIDE PCGTs	31	CA-1047	AUGER, WIRE ASSY
3	CA-1109-01	FILM, CURTIS LOGO PCGT-3	32	CA-1036	GEAR, PLASTIC PC'S USE ON CA-1013
3A	CA-1148-01 <sup>2</sup>	FILM, CURTIS LOGO <b>PRESET DISPENSE</b>	33	WC-37174*	KIT, GEAR MOTOR, CORK BRAKE PCGT
3B	CA-1144-01 <sup>3</sup>	FILM, LIGHT BOX <b>ICED CAPPUCCINO</b>	34	WC- 780*	CONTROL, POWER MODULE CORK BRAKE
4	WC-68165-101	DOOR, COMPLETE PCGT3	34A	WC- 799 <sup>2</sup>	UNIVERSAL POWER MODULE <b>PRESET DISP</b>
5	CA-1123	LAMP, 30W 5K CIRCULAR FCL 30	35	WC-8556*	HEAT SINK ASSEMBLY DV PCGTs
5A	CA-1174	LAMP, LED ASSY 11-12W 36VDC	36	WC-3739*	KIT, WHIPPER MOTOR, SCREWS & INSTR
6	CA-1127	LAMP COMPLETE 30W PCGT (INCL BULB)	37	WC-66043	CANISTER TRAY, ASSY PLASTIC PCGT3
6A	CA-1174-101	POWER SPLY, (FOR ITEM 5A) 36VDC	38	WC-37123	KIT, FAN EXTRACT 120V 29 CFM & BRACKET
7	CA-1101	WINDOW, FRONT CLEAR PCGT-3	39	WC-58121	COVER, DUMP VALVE PC-3GT
8	WC-39958	LABEL ASSY, UCM & DOOR PCGT-3	40	CA-1095	CONNECTOR, ORIFICE WATER PCGT
8A	WC-39618 <sup>2</sup>	LABEL ASSY, UCM & DOOR <b>PRESET DISP</b>	41	CA-1011-05	FITTING, BULKHEAD WATER PCGTs
9	WC-37126	KIT, UCM BOARD & LABEL PCGT3	42	WC-43791	RING, MOTOR SHAFT PLASTIC
9A	WC- 795 <sup>2</sup>	CONTROL MODULE, <b>PRESET DISPENSE</b>	43	CA-1005-03	STEAM TRAP PC/CK/HC
10	CA-1173	COVER, ALCOVE PCGT-3	44	CA-1009-03	BOWL, MIXING PC/CK/HC
11	WC-68160	SCREEN, DRIP TRAY PCGT-3	45	CA-1006-06	WHIPPER CHAMBER OFFSET PCGTs
12	CA-1160	DRIP TRAY, PLASTIC PCGT-3	46	CA-1037-3Y	TUBE, EXTENSION 3.0" LONG YELLOW
13	WC-3518	LEG, GUIDE 3/8"-16 STUD SCREW	47	WC-37118*	KIT, WHIPPER PLATE (W/SEAL) 3/PKG
14	WC-68121	PANEL, RIGHT SIDE PCGTs	48	WC-66007*	SEAL, MOTOR SHAFT PC'S SOFT (20/PKG)
15	WC-3503	LEG, 3/8"-16 STD SCREW BUMPER	49	CA-1024-05	PILLAR, LOCATION BLACK
16	WC-8591*	CAPACITOR, X2 ALL ADS MODELS	50	CA-1008-07K*	KIT, PROPELLER OFFSET BLADES 6/PKG
17	WC-5310*	TUBE, 5/16" ID X 1/8"W SILICONE	51	WC-37008*	KIT, TANK LID ROUND
18	CA-1030-17*	HOSE, EXTRACTOR FAN 17" LONG	52	WC-43067*	O-RING, 4-1/2 I.D. x Ø.285 SILICONE
19	WC-39350-02*	LABEL, PANEL FLAVOR CURTIS PCGTs	53	WC-5502-01*	PROBE, LIQUID LEVEL
20	WC-39203	LABEL, SERVICING INSTRUCTIONS	54	WC-2627*	BUSHING, CONICAL .583IDx.945ODx.945LG
21	WC-13245	HARNESS ASSY, COMPLETE PCGTs	55	WC-2630*	BUSHING, CONICAL BLIND
22	CA-1113-06L	CANISTER ASSY, 10LB LEFT PCGTs	56	WC-3734*	KIT, RPL DUMP VALVE FOR WC-880E PCGTs
23	CA-1112-06	CANISTER ASSY, 5LB PCGTs	57	WC-6294	HEATING TANK, COMPLETE PCGT3
24	CA-1113-06R	CANISTER ASSY, 10LB RIGHT PCGTs	58	WC- 904-04*	HEATING ELEMENT, 1.6KW W/JAMNUTS
25	CA-1026-03	ELBOW, PC/CK/HC	59	WC-1438-101	SENSOR, TEMPERATURE TANK
26	CA-1065-03	BUSHING, DISCHARGE PC/CK/HC	60	WC- 523*	THERMOSTAT, MNL RESET 120/240V 25A
27	WC-8539	NUT, RETAINER	61	WC- 102*	SWITCH, TOGGLE NON LIT 15A 120/240V
28	CA-1002-01	LID, CANISTER 5LB	62	WC- 826L*	VALVE, INLET 1 GPM 120V 10W YELLOW
28A	WC-5664-05	LID, CANISTER 10LB	63	WC-3765L *	KIT, INLET VALVE REPAIR USE ON WC-826L
29	CA-1051-03	SOCKET, GEAR 6mm x 1mm PITCH LHT	64	WC-5231*	COMPOUND, SILICONE 5 OZ TUBE

<sup>2</sup> FOR PRESET DISPENSE UNITS

<sup>3</sup> FOR ICED CAPPUCCINO

\* RECOMMENDED PARTS TO STOCK



HOT CHOCOLATE	FAT FREE FRENCH VANILLA	CAPPUCCINO
ICED CAPPUCCINO	ALMOND AMARETTO	BANANA NUT
CHOCOLATE MINT	ENGLISH TOFFEE	HAZELNUT
IRISH CREAM	VANILLA CREAM	FRENCH VANILLA
DECAF	COFFEE	ORIGINAL CAPPUCCINO
CINNAMON VANILLA NUT	CHAI	RASPBERRY MOCHA
ALMOND AMARETTO	HOT CHOCOLATE	CAPPUCCINO
ICED CAPPUCCINO	HAZELNUT	FRENCH VANILLA

# Illustrated Parts Main View

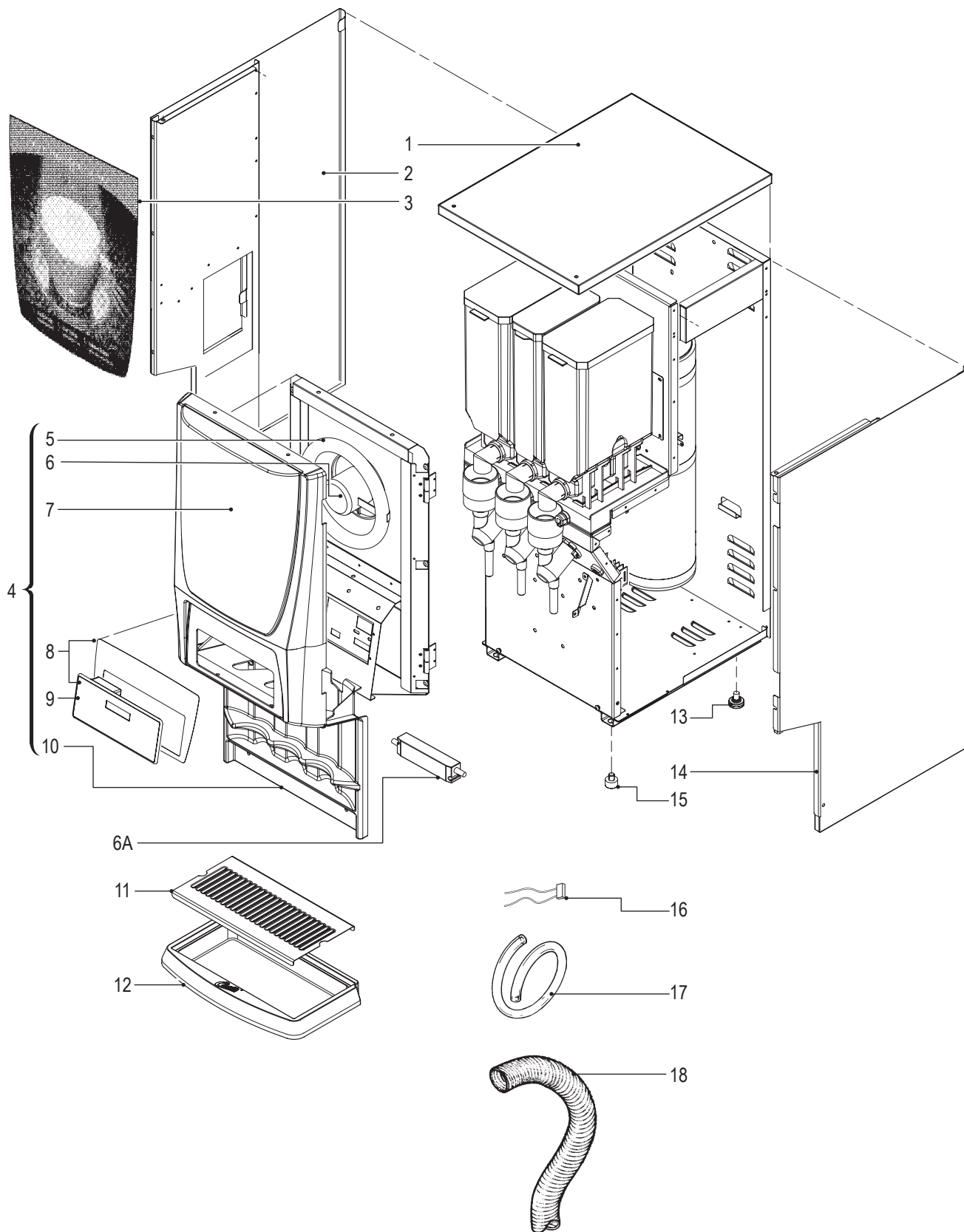

# Illustrated Parts Chassis

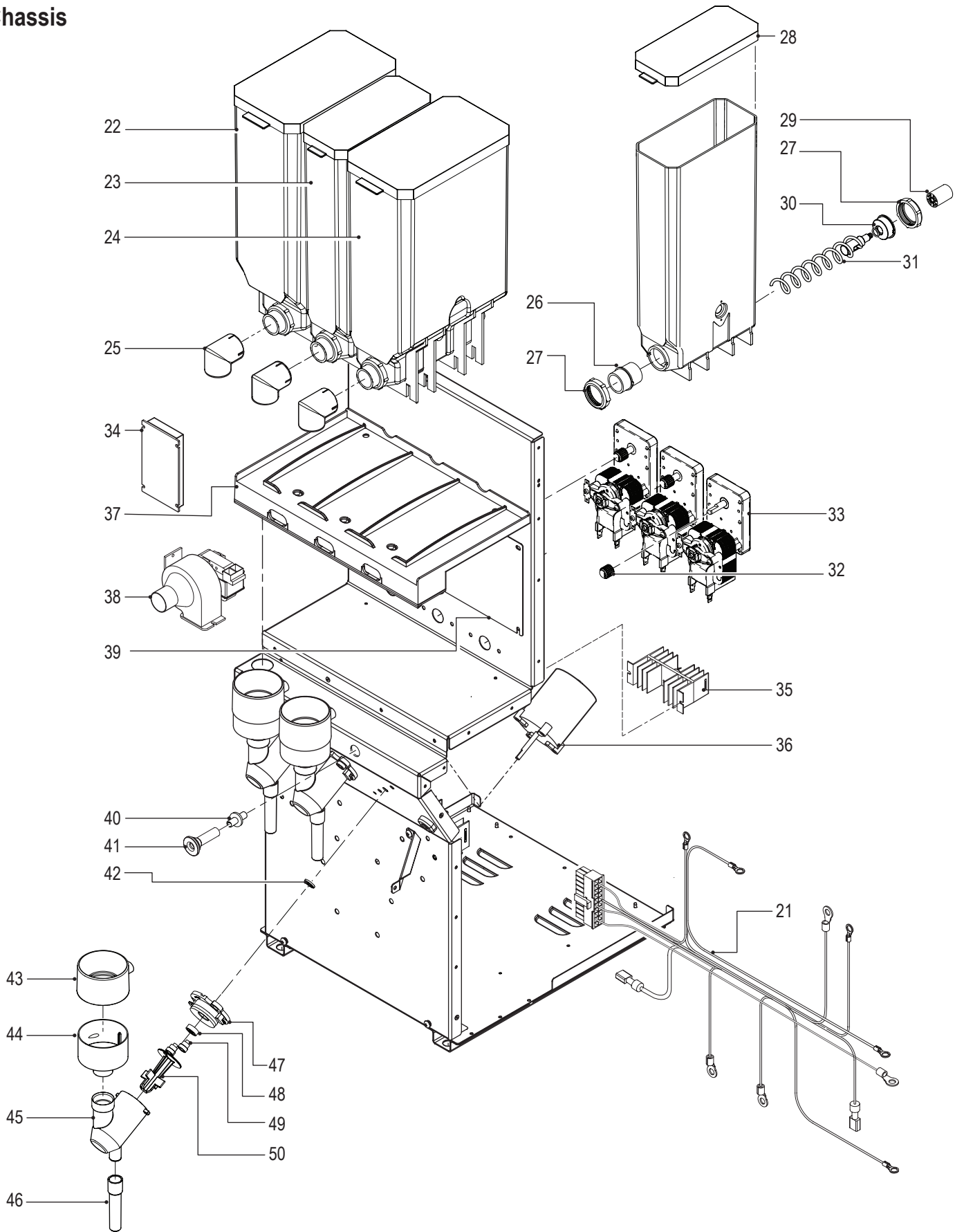

## Illustrated Parts Heating Tank

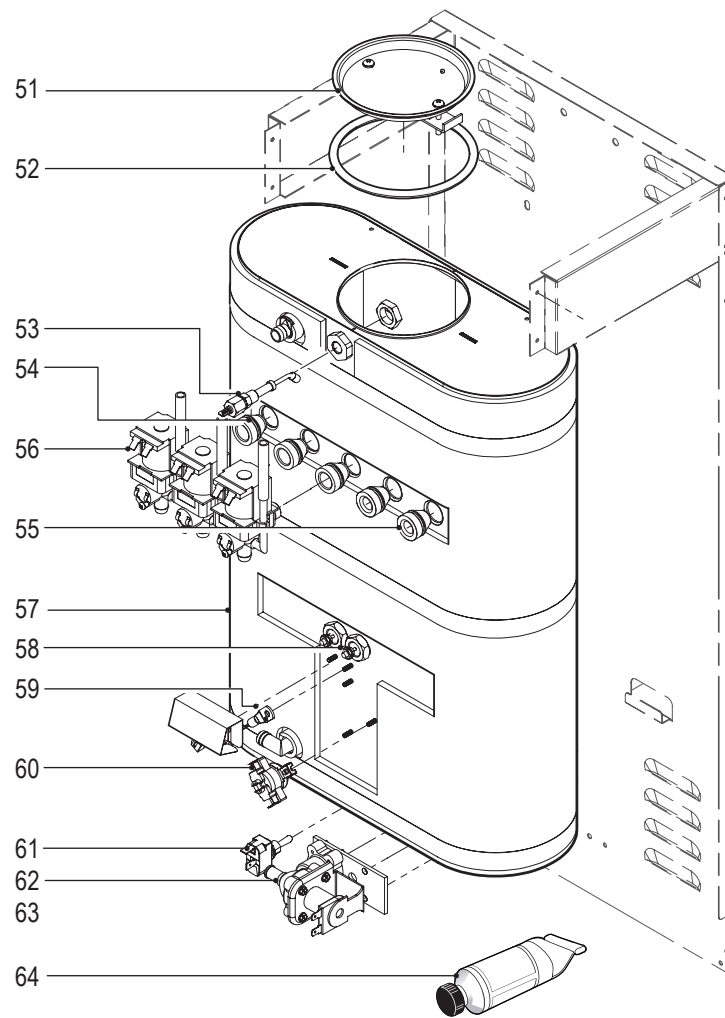

**IMPORTANT:** Shaft seals should be replaced with the grooved side facing outward. Place a dab of food grade lubricant in the rear hole of the seal, as shown below.

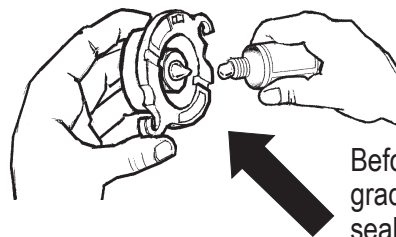
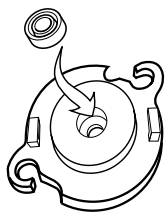

Before mounting a whipper plate, place a dab of food grade lubricant into the rear, motor shaft hole of the seal.

# Rough-In Drawing

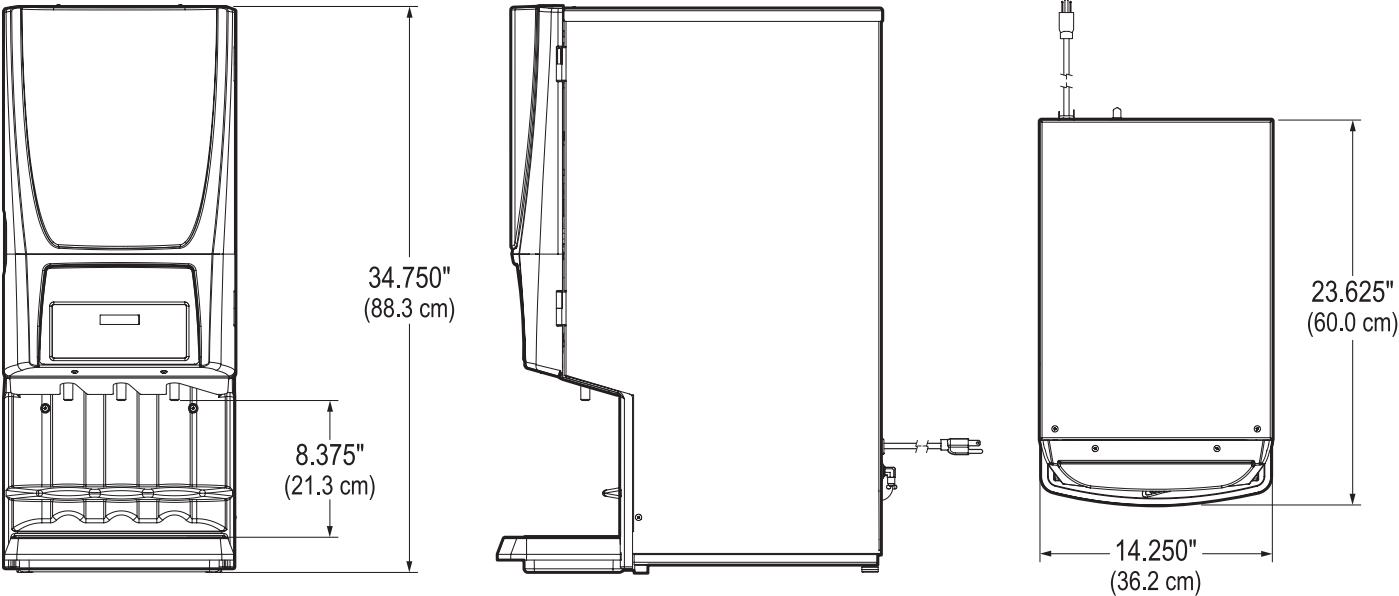



# Electrical Diagram

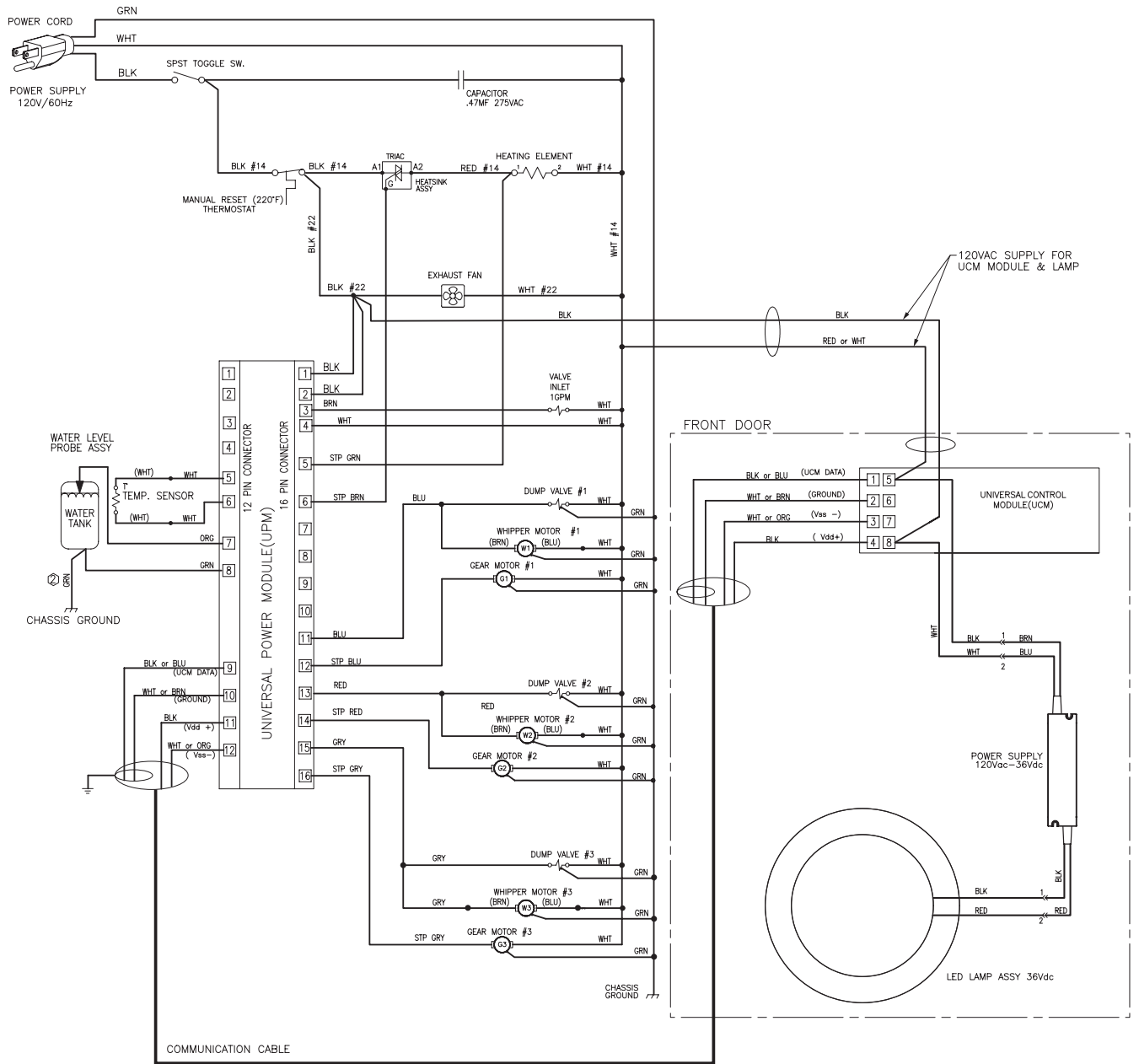

### UPM CONNECTOR PIN ASSIGNMENTS

- |                   |                        |
|-------------------|------------------------|
| 1: 120Vac HOT     | 1: NOT USED            |
| 2: 120Vac HOT     | 2: NOT USED            |
| 3: INLET VALVE    | 3: NOT USED            |
| 4: 120Vac NEUTRAL | 4: NOT USED            |
| 5: TRIAC A2       | 5: TEMPERATURE SENSOR  |
| 6: GATE TRIAC     | 6: TEMPERATURE SENSOR  |
| 7: NOT USED       | 7: WATER LEVEL PROBE   |
| 8: NOT USED       | 8: TANK/CHASSIS GROUND |
| 9: NOT USED       | 9: UCM DATA            |
| 10: NOT USED      | 10: UCM DATA GROUND    |
| 11: DUMP VALVE #1 | 11: Vdd+               |
| 12: GEAR MOTOR #1 | 12: Vss-               |
| 13: DUMP VALVE #2 |                        |
| 14: GEAR MOTOR #2 |                        |
| 15: DUMP VALVE #3 |                        |
| 16: GEAR MOTOR #3 |                        |

### UCM CONNECTOR PIN ASSIGNMENTS

- |                    |
|--------------------|
| 1: UCM DATA        |
| 2: UCM DATA GROUND |
| 3: Vss-            |
| 4: Vdd+            |
| 5: 120Vac NEUTRAL  |
| 6: NOT USED        |
| 7: NOT USED        |
| 8: 120Vac HOT      |

### TRIAC PIN ASSIGNMENTS

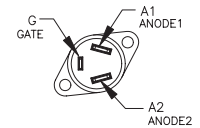

### ELECTRICAL RATING TABLE

MACHINE	US MODELS		CANADIAN MODELS		HEATING ELEMENT (WATTS)
	TOTAL POWER (WATTS)	TOTAL CURRENT (AMP.)	TOTAL POWER (WATTS)	TOTAL CURRENT (AMP.)	
(SC)PCGT3C10000	1800	15			1600
(SC)PCGT3C20000			1350	12	1150

VOLTAGE:	120VAC
WATTAGE:	SEE TABLE
AMPERAGE:	SEE TABLE
HERTZ:	50/60HZ
WIRES:	2W+G
PHASE:	1PH

PART NUMBER:	<b>LD-PCGT3-10</b>	REVISION:	<b>E</b>
--------------	--------------------	-----------	----------

② INSTALL GROUND ON TANK BEFORE CHASSIS.  
 1. ALL WIRES SHALL BE MIN 18 AWG.  
 NOTES: UNLESS OTHERWISE SPECIFIED

## Product Warranty Information

The Wilbur Curtis Company certifies that its products are free from defects in material and workmanship under normal use. The following limited warranties and conditions apply:

- 3 Years, Parts and Labor, from Original Date of Purchase on digital control boards.
- 2 Years, Parts, from Original Date of Purchase on all other electrical components, fittings and tubing.
- 1 Year, Labor, from Original Date of Purchase on all electrical components, fittings and tubing.

Additionally, the Wilbur Curtis Company warrants its Grinding Burrs for Forty (40) months from date of purchase or 40,000 pounds of coffee, whichever comes first. Stainless Steel components are warranted for two (2) years from date of purchase against leaking or pitting and replacement parts are warranted for ninety (90) days from date of purchase or for the remainder of the limited warranty period of the equipment in which the component is installed.

All in-warranty service calls must have prior authorization. For Authorization, call the Technical Support Department at 1-800-995-0417. Effective date of this policy is April 1, 2003.

Additional conditions may apply. Go to [www.wilburcurtis.com](http://www.wilburcurtis.com) to view the full product warranty information.

### CONDITIONS & EXCEPTIONS

The warranty covers original equipment at time of purchase only. The Wilbur Curtis Company, Inc., assumes no responsibility for substitute replacement parts installed on Curtis equipment that have not been purchased from the Wilbur Curtis Company, Inc. The Wilbur Curtis Company will not accept any responsibility if the following conditions are not met. The warranty does not cover and is void under the following circumstances:

- 1) **Improper operation of equipment:** *The equipment must be used for its designed and intended purpose and function.*
- 2) **Improper installation of equipment:** *This equipment must be installed by a professional technician and must comply with all local electrical, mechanical and plumbing codes.*
- 3) **Improper voltage:** *Equipment must be installed at the voltage stated on the serial plate supplied with this equipment.*
- 4) **Improper water supply:** *This includes, but is not limited to, excessive or low water pressure, and inadequate or fluctuating water flow rate.*
- 5) **Adjustments and cleaning:** *The resetting of safety thermostats and circuit breakers, programming and temperature adjustments are the responsibility of the equipment owner. The owner is responsible for proper cleaning and regular maintenance of this equipment.*
- 6) **Damaged in transit:** *Equipment damaged in transit is the responsibility of the freight company and a claim should be made with the carrier.*
- 7) **Abuse or neglect (including failure to periodically clean or remove lime accumulations):** *Manufacturer is not responsible for variation in equipment operation due to excessive lime or local water conditions. The equipment must be maintained according to the manufacturer's recommendations.*
- 8) **Replacement of items subject to normal use and wear:** *This shall include, but is not limited to, light bulbs, shear disks, "O" rings, gaskets, silicone tube, canister assemblies, whipper chambers and plates, mixing bowls, agitation assemblies and whipper propellers.*
- 9) **Repairs and/or Replacements** *are subject to our decision that the workmanship or parts were faulty and the defects showed up under normal use. All labor shall be performed during regular working hours. Overtime charges are the responsibility of the owner. Charges incurred by delays, waiting time, or operating restrictions that hinder the service technician's ability to perform service is the responsibility of the owner of the equipment. This includes institutional and correctional facilities. The Wilbur Curtis Company will allow up to 100 miles, round trip, per in-warranty service call.*

**RETURN MERCHANDISE AUTHORIZATION:** *All claims under this warranty must be submitted to the Wilbur Curtis Company Technical Support Department prior to performing any repair work or return of this equipment to the factory. All returned equipment must be repackaged properly in the original carton. No units will be accepted if they are damaged in transit due to improper packaging. **NO UNITS OR PARTS WILL BE ACCEPTED WITHOUT A RETURN MERCHANDISE AUTHORIZATION (RMA). RMA NUMBER MUST BE MARKED ON THE CARTON OR SHIPPING LABEL.** All in-warranty service calls must be performed by an authorized service agent. Call the Wilbur Curtis Technical Support Department to find an agent near you.*

revA . 6/11/12@13.9 . ECN 14151



**WILBUR CURTIS CO., INC.**

6913 Acco St., Montebello, CA 90640-5403 USA

Phone: 800/421-6150 ♦ Fax: 323-837-2410

♦ Technical Support Phone: 800/995-0417 (M-F 5:30A - 4:00P PST) ♦ E-Mail: [techsupport@wilburcurtis.com](mailto:techsupport@wilburcurtis.com)

♦ Web Site: [www.wilburcurtis.com](http://www.wilburcurtis.com)

FOR THE LATEST SPECIFICATION INFORMATION GO TO [WWW.WILBURCURTIS.COM](http://WWW.WILBURCURTIS.COM)