

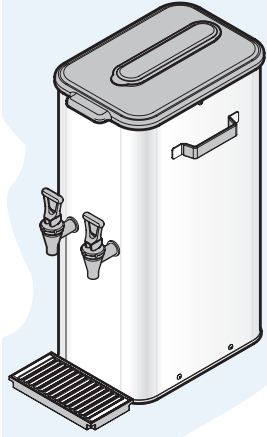

WILBUR CURTIS COMPANY, INC.

Service Manual, TCC



Models Included

- TCC1
- TCC2
- TCC3



NOTE: Water source pressure must be a minimum of 30 PSI pressure at all times to insure the quality of the of the product.



ISO 9001:2008 REGISTERED

WILBUR CURTIS CO., INC.
6913 West Acco Street
Montebello, CA 90640-5403
For the latest information go to www.wilburcurtis.com
Tel: 800-421-6150
Fax: 323-837-2410

Important Safeguards/Symbols

This appliance is designed for commercial use. Any servicing other than cleaning and maintenance should be performed by an authorized Wilbur Curtis service center.

- Do NOT immerse the unit in water or any other liquid
- Never clean with scouring powders, bleach or harsh chemicals.

Symbols:



WARNINGS – To help avoid personal injury



Important Notes/Cautions



Sanitation Requirements

Curtis TCC Units are Factory Pre-Set and Ready to Go... Right out of the Box.

Generally there will never be a reason to change factory settings. However, should you need to make slight adjustments to meet your tea needs, adjustment instructions are provided later in this manual.

System Requirements:

- Water Source 30 – 90 PSI (Minimum Flow Rate of 1 GPM). If incoming water supply is greater than 90 PSI, additional regulation is required to meet the range.
- Water pipe connections and fixtures directly connected to a potable water supply shall be sized, installed and maintained in accordance with federal, state, and local codes.

SETUP STEPS

The unit should be level (left to right and front to back), located on a solid counter top. Connect a water line from the water filter to the TCC server. **NOTE:** Some type of water filtration device must be used to maintain a trouble-free operation. (In areas with extremely hard water, we suggest that a sedimentary and taste & odor filter be installed.) This will prolong the life of your system and enhance tea quality.

INSTALLATION

1. Remove dispenser from carton.
2. Run a water line to the inlet fitting behind the dispenser. Flush the new water-line to remove foreign particles.
3. Connect a 1/4" flared flexible or copper waterline to the male fitting on the back of the dispenser.
4. Locate the water supply valve behind the unit to verify position is turned on.

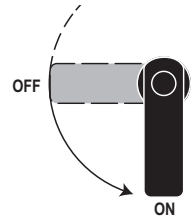

CAUTION: We recommended that the water supply valve, behind unit, be turned off during non-business hours.



NSF International requires the following water connection:

1. A quick disconnect or additional coiled tubing (at least 2x the depth of the unit) so that the machine can be moved for cleaning underneath.
2. This equipment is to be installed with adequate backflow protection to comply with applicable federal, state and local codes..
3. Water pipe connections and fixtures directly connected to a potable water supply shall be sized, installed and maintained in accordance with federal, state, and local codes.

5. Clean out the tea concentrate system before using the TCC server. Use a Bag-in-Box style cleaning solution to simplify the cleaning procedure. A cleaner like BevClean beverage line cleaner comes in a 3 gallon bag-in-box that connects directly to your bag-in-box system for line cleaning (<http://bevclean.com>).
 - a. Remove the quick disconnect from the tea concentrate bag.
 - b. Place the BIB cleaner container next to the TCC tea dispenser. Pull the spout from the cleaner box through the marked area. Remove the clear travel cap from spout. Don't worry about cleaner spilling when the cap is removed. The cap has an internal seal.
 - c. Snap the QCD bag connector onto the bag spout.

FOR THE LATEST SPECIFICATIONS AND INFORMATION GO TO WWW.WILBURCURTIS.COM

- d. Grasping the bag connector (as shown in Load Product, step 6), push the sliding probe all the way into the bag spout. A “click” will be heard when it is fully inserted.
- e. Once the cleaning solution box is connected, open the dispensing valve on the dispenser and run liquid through the valve until the sanitizer (clear liquid) is detected. The dispensing line is now clean.
- f. Disengage the bag connector by snapping the connector probe out and remove the connector from the spout.
- g. Reattach the tea concentrate BIB.
- h. Open dispensing valve on dispenser until tea flows freely.

LOAD PRODUCT

Bag-In-Box

1. Place a tea concentrate bag on the counter next to the TCC dispenser.
2. Remove the top cover from the TCC dispenser and pull out the hose with the QCD bag connector.



3. Pull off the shipping cap that covers the spout on the bag.

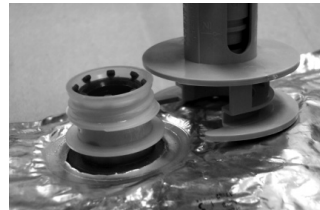

4. Place the QCD next to the spout.

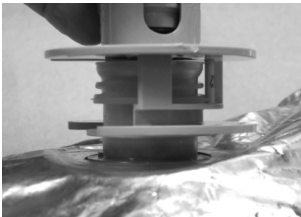

5. Slide QCD sideways, over the bag spout. QCD snaps in place.



6. Push QCD plunger into bag spout until plunger top is flush with top of QCD. A “click” will be heard when it is fully inserted.

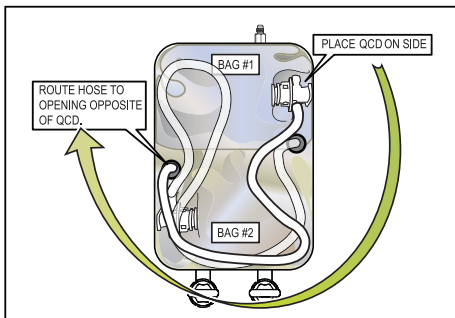

TOP VIEW OF TCC SHOWING PREFERRED ORIENTATION OF TEA CONCENTRATE BAGS AND HOSE ROUTING

7. Carefully lift the bag and set the bag into the dispenser.
8. Rest tubing on top of the bag. Route tubing to opposite product intake hole on floor of dispenser (see illustration, left).
9. Replace the top cover.
10. Dispense beverage from faucet until darker product starts to appear (~5 seconds).
11. The TCC server is now ready to dispense tea.

WATER PRESSURE AND MIXING VALVE

The pressure regulator should rarely be changed. Primary taste / brix adjustments should be done via the mixing valve by turning the rod and tasting the finished product. 98% of flavor adjustments should be done in this manner.

The purpose of the regulator is to provide uniform water pressure so the venturi-style mixing device can produce a stable and uniform blend of concentrate and water and also to protect the hydraulics of the dispensing unit from “line pressure”. It is not the primary adjustment for the brix level. From our testing, it has been shown that exact PSI on the gage does not directly correlate to a brix level from unit to unit and from installation location to installation location.

Secondarily, if the primary adjustment doesn’t provide the ideal brix level, call Curtis Care for instructions on how to adjust the regulator. As a rule, very little taste adjustment is achieved via the pressure regulator.

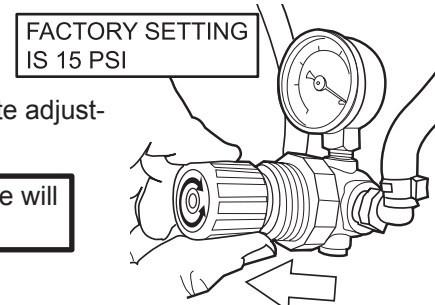
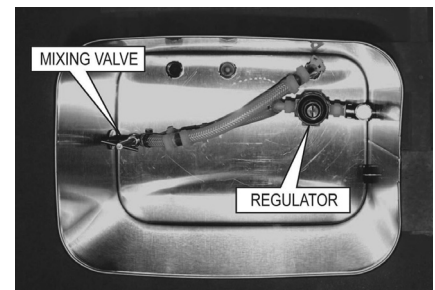

CAUTION: Do Not Exceed 25 psi (static). Equipment failure or leakage will result.

MIXING VALVE ADJUSTMENT:

For customers who wish to adjust the flavor of the drink, the mixing valve changes the water to concentrate ratio. This valve is very sensitive. Only slight rotation of the mixing rod is needed to change the ratio (1/16th to 1/8th of a turn). The standard setup, as the unit comes from the factory, is approximately 7:1 ratio, which will give you a 5 to 8 percent brix based on the sweet tea concentrate.

1. To adjust the valve, tilt the dispenser on it's side.
2. Look underneath the unit and locate the adjusting rod.
3. Turn counter-clockwise for stronger drink – turn clockwise for weaker drink. Taste the tea with each adjustment to determine the desired consistency.

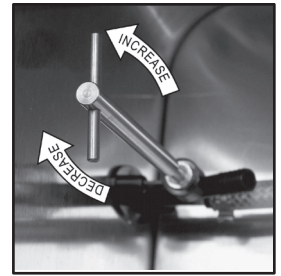

CAUTION – Do not rotate adjusting rod more than 2 full turns from closed position. More turns will cause the adjustment rod to disengage from the mixing valve, with a resulting leak.

TEA TIPS



WARNING DO NOT refrigerate unused tea overnight for later consumption.

1. Never hold finished dispensed tea for more than eight hours at room temperature. Discard any unused tea after eight hours
2. Dispense only enough tea that you reasonably expect to sell within a few hours.
3. To protect tea flavor and to avoid bacterial contamination and growth, clean and sanitize tea brewing, storage and dispensing equipment at least once a day.

CLEANING STRAINER CLEAN-OUT

1. Turn off the water flow running from the facility to the strainer.
2. Use pliers to grab the housing of the strainer and with an adjustable wrench, remove the cap.
3. Take out the wire strainer and clean out the contents. Use a spiral bristled brush to clean inside the strainer.
4. Rinse the strainer and replace it into the housing.
5. Return the cap to the housing and turn on the water line.

DAILY CLEANING

Regular cleaning of the TCC dispenser is essential in maintaining the highest quality iced tea your equipment is capable of producing.

1. Wipe any spills, dust or debris from the exterior surfaces, with a damp cloth. Apply a stainless steel polish to prevent scratches.
2. Turn off water supply at valve behind unit.
3. Open the dispensing faucet to relieve pressure in the dispensing lines.
4. Remove the top cover and clean with detergent solution.
5. Clean the faucet assembly.
 - a. Unscrew the handle assembly from the faucet and remove.
 - b. Clean the faucet cap and silicone seat cup.
 - c. Use a spiral brush to clean inside the faucet body.
6. Rinse and dry parts that were removed. Assemble them to the unit.

WEEKLY CLEANING & SANITIZING

Use a concentrated cleaning solution to simplify the cleaning procedure. This procedure requires a one gallon container of a cleaning solution containing hot water and a granulated concentrated cleaner (a cleaner like Coffee Dispenser Cleaner Corporation #12580, Urnex or equivalent) and a one gallon container of clean hot water.

1. Turn on water supply to the dispenser.
2. Remove the quick disconnect from the tea concentrate bag.
3. Pull the cap off of the QCD (see detail drawing) and place this end of the line into the container containing the cleaning solution.
4. Place a large empty container under the dispenser faucet.
5. Open the front faucet and dispense at least half of the cleaning solution.
6. Allow the dispenser to sit overnight before flushing cleaning solution.
7. Flush the system by filling a one gallon container with clean hot water (no cleaning solution) and open the faucet and dispense at least one gallon of the hot water or until all the cleaning solution has been flushed from the system.
8. Remove the QCD from the flushing container and replace the cap. Reconnect the QCD to the Bag in the Box tea concentrate and dispense several cups to prime the concentrate line or until consistency of the product is correct.

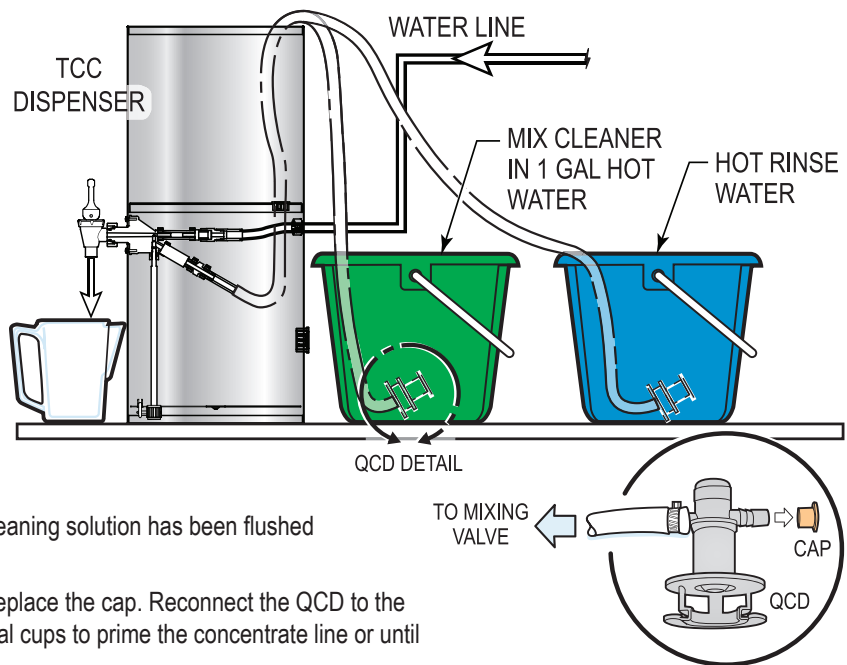

SANITIZING

Use a Bag-in-Box style cleaning solution to simplify the sanitizing procedure. A product like BevClean (<http://bevclean.com>) beverage line sanitizer comes in a 3 gallon bag-in-box that connects directly to your bag-in-box system for line sanitizing.

1. Remove the quick disconnect from the tea concentrate bag.
2. Place the BIB sanitizer container next to the TCC tea dispenser. Pull the spout from the sanitizer box through the marked area. Remove the clear travel cap from spout. Don't worry about spilling sanitizer when the cap is removed. The cap has an internal seal.
3. Snap the QCD bag connector onto the bag spout.
4. Grasping the bag connector (as shown in Load Product, step 6), push the sliding probe all the way into the bag spout. A "click" will be heard when it is fully inserted.
5. Once the cleaning solution box is connected, open the dispensing valve on the dispenser and run liquid through the valve until the sanitizer (clear liquid) is detected.



DO NOT FLUSH. Allow the sanitizing solution to sit in the tea lines overnight before proceeding with line flushing steps 6 through 8, below.

6. Remove the QCD from the BIB cleaner. Unsnap the connector probe, pulling out and removing the connector from the spout.
7. Flush the line with warm water to remove any cleaning solution.
7. Reattach the tea concentrate BIB product.
8. Open the dispensing faucet in front of the dispenser and allow water to run out until tea flows from the faucet.
9. Repeat the process for any additional faucets on dispenser.

Note: Multi-outlet manifolds are available for sanitizing up to eight beverage lines with one bag-in-box sanitizer. This allows you to clean all systems at one time.

ROUGH-IN DRAWINGS

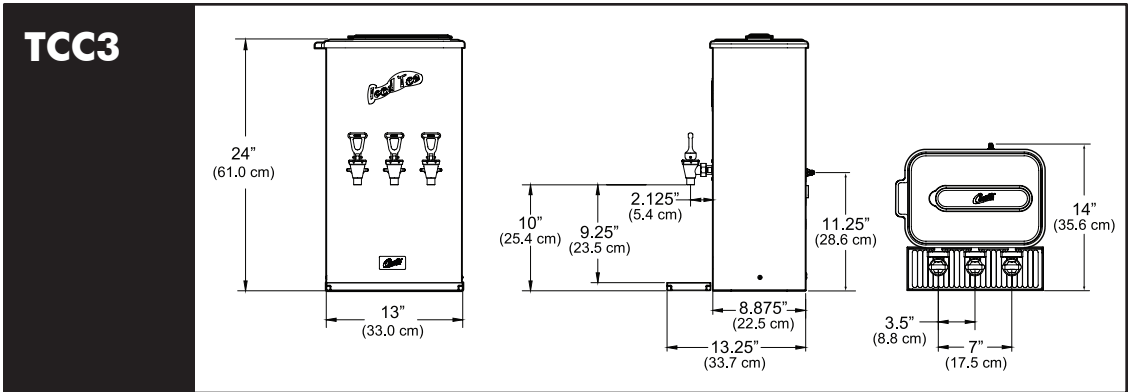
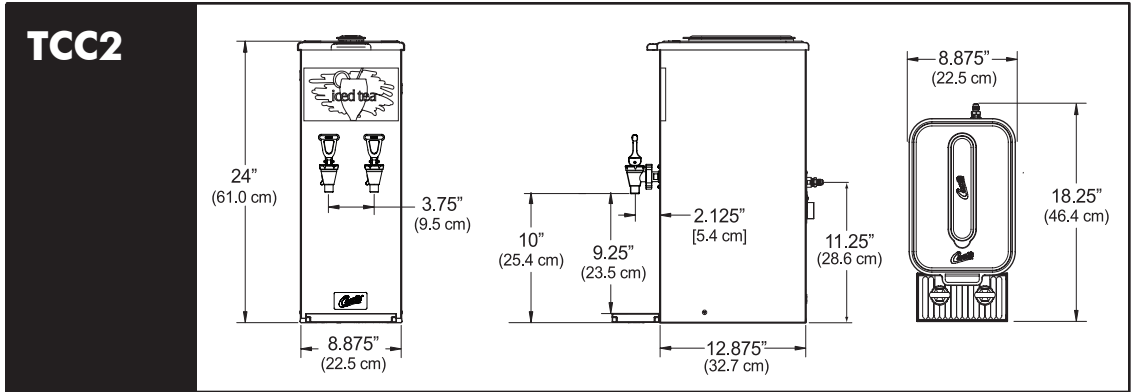
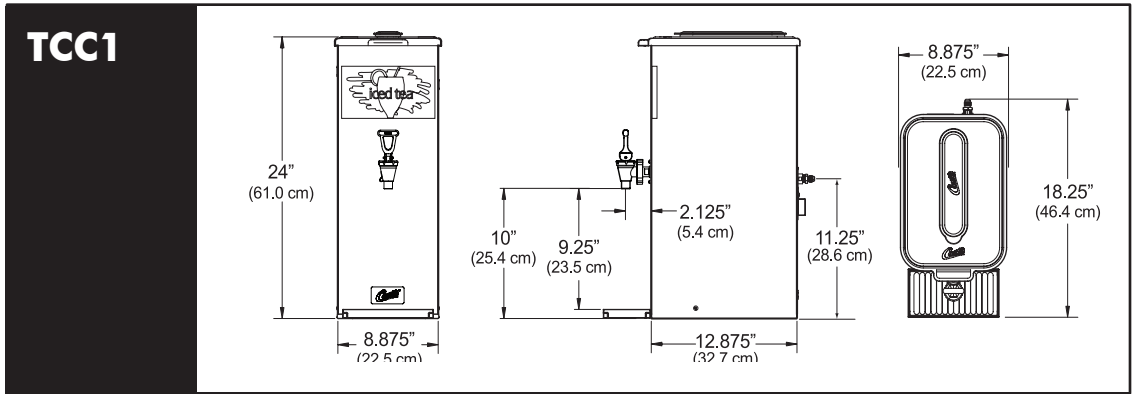

ILLUSTRATED PARTS LIST

TCC1 (single) is shown on page 6. The twin (TCC2) has two faucet/mixing valve systems and two QDC connectors. Parts are common between both units except where noted below. TCC3 Illustrated Parts List is shown on page 7.

ITEM N°	PART N°	DESCRIPTION	ITEM N°	PART N°	DESCRIPTION
1	WC-8653*	QCD, LIQUID BOX BAG CONNECTOR	12	WC- 811-102*	REGULATOR, PRESSURE 1/4" 0-30 PSIG BRS
2	WC-14022	CLAMP, TUBING 15.3-18.5mm SS OETIKER	13	WC-14021	CLAMP, TUBING 14.2-706R TCC
3	WC-53120*	TUBING, 3/8"ID X 9/16"OD CLEAR PVC	14	WC-53113*	TUBING, .25" ID X .50" OD BRAID SILICONE
4	WC-43002	CLAMP, HOSE SNAP NYLON .525/.605	15	WC-2219*	Y'FITTING BARB 1/4x1/4x1/4 WHT NYLON
5	WC-2615	CONNECTOR, 1/4 FLARE X 1/4 NPT PLTD	16	WC-5683*	LID ASSY, TCO BLACK PLASTIC
6	WC-2508	ELBOW, 1/4 NPT PLATED TCC	16A	WC-5683-101	LID ASSY, BLUE PLASTIC (OPTIONAL)
7	WC-29078	NIPPLE, HEX 1/4" X 1/4 MNPT PLATED	17	WC- 894*	MIXING VALVE
8	WC- 870P-101	VALVE, BALL 1/4 FPT X 1/4 MTP PLT'D	18	WC-1903*	NUT, UNION SHANK
9	WC-1045	STRAINER, 1/4 FNPT 90° FLOW PATH PLTD	19	WC-1906*	C' RING .917 X .760 X .090
10	WC-2445*	STEM, 3/8 BARB x 3/8 STEM	20	WC-4320*	O' RING, .487 ID X .103 CS
11	WC-2452*	VALVE, CHECK 3/8 OD TUBE x 3/8 OD TUBE	21	WC-1829*	FAUCET, ASSY TCC BLK

Parts List Continued on Page 6 . . .

ITEM N°	PART N°	DESCRIPTION
22	WC-2435	ELBOW, 1/4" MNPT X 1/4 BARB NYLON
23	WC-43084*	O-RING, .070" ID X .070"W BUNA-N
24	WC-37312*	KIT, ADJUSTING ROD & O-RING TCC
24A	WC-29070	ROD, ADJUSTABLE TCC COFFEE
25	DTP-08*	DRIP TRAY, 8"

ITEM N°	PART N°	DESCRIPTION
26	WC-37288*	KIT, CHECK VALVE, CLAMPS & INSTR.
27	WC-37293*	KIT, CHECK VALVE (2 VALVES & INSTR)
28	WC-53117-101	TUBE, BOTTLE ADAPTER (OPTIONAL)
29	WC-29079	NIPPLE, HEX 1/4" NPT X 1/4 NPT NYLON
30	WC-8654	CONNECTOR, SCHOLLE L' (ICED COF)

* Recommended Parts to Stock

ILLUSTRATED PARTS
TCC1 SHOWN, TCC2 COMPONENTS
ARE SIMILAR

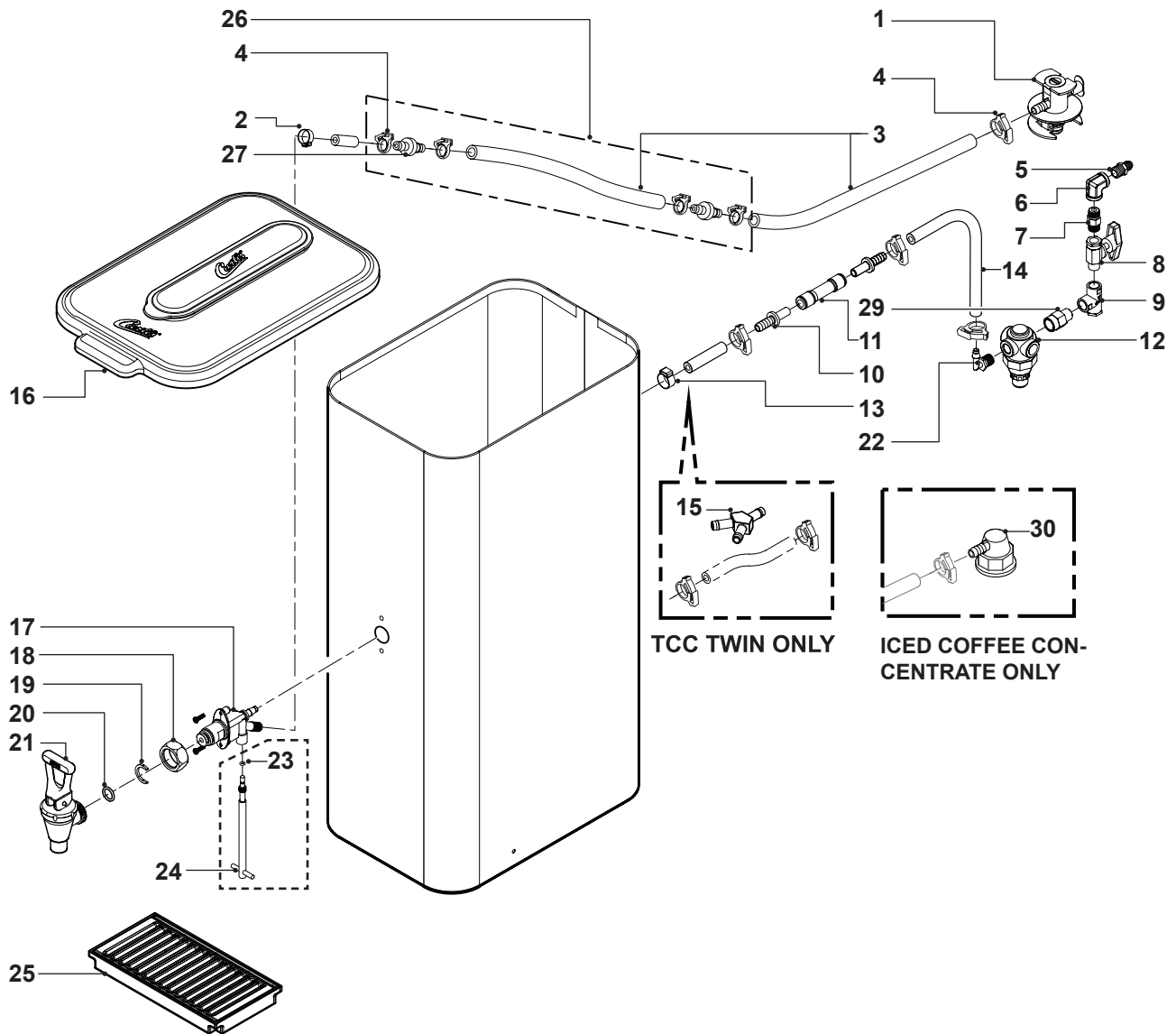

ILLUSTRATED PARTS

TCC3

ALL PARTS ARE IDENTICAL TO TCC1 & TCC2, EXCEPT WHERE NOTED

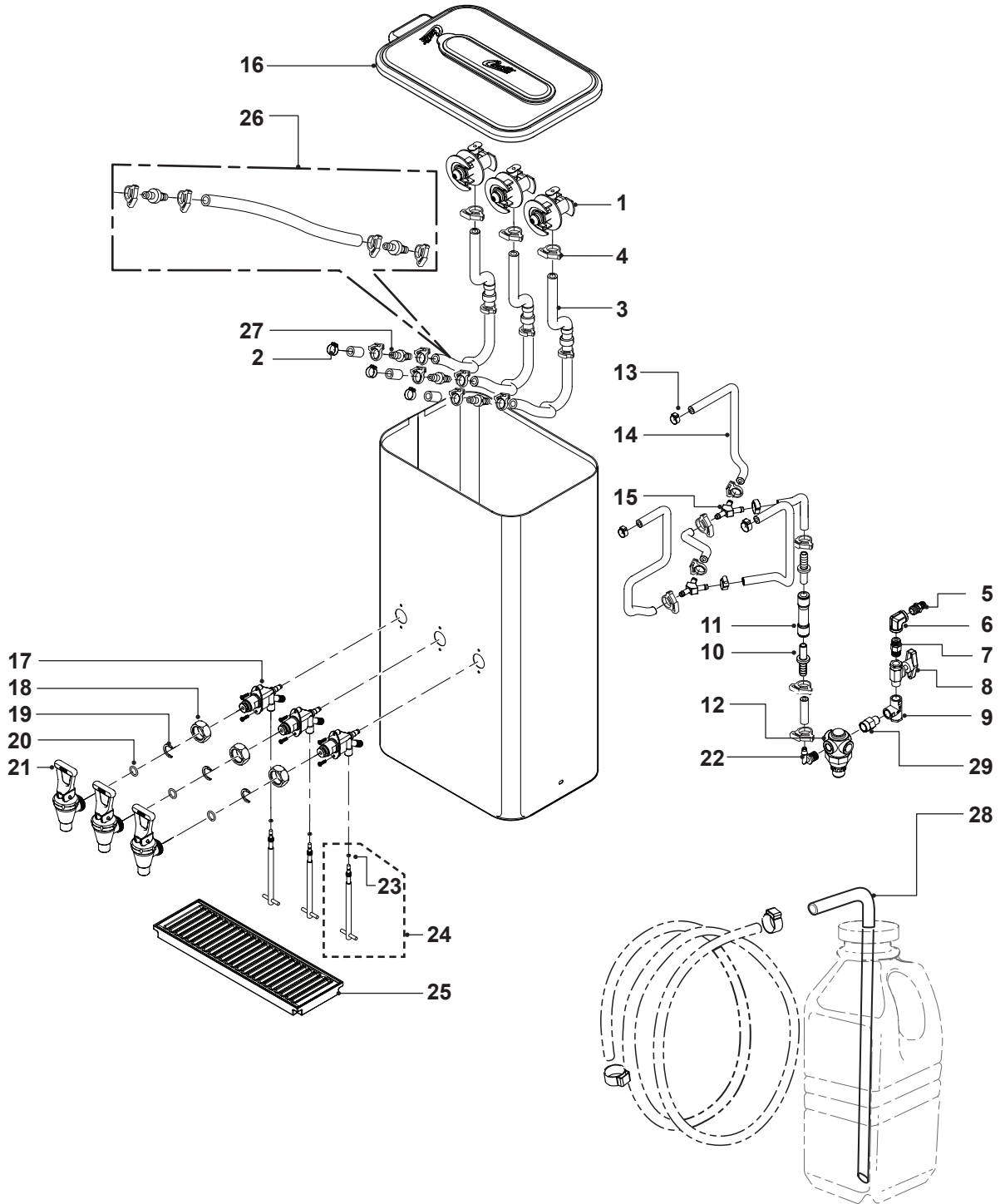

DOs and DON'Ts

INSTALLATION	OPERATION
<ol style="list-style-type: none">1. Do connect dispenser to a filtered waterline.2. Do flush filters before connecting to dispenser.3. Do sample finished drink before making adjustments.4. Do make very slight drink adjustments then sample.5. Don't forget to flush filters before installation.6. Don't make any pressure regulator adjustments on dispenser (Do NOT attempt to adjust the regulator. If a regulator adjustment is required call CURTIS CARE).7. Don't forget to get sample approval from customer.	<ol style="list-style-type: none">1. Do fully activate faucet handle when dispensing drinks.2. Do clean & sanitize dispensing assembly monthly.3. Do keep dispenser primed with concentrate at all times.4. Do reload immediately when out of concentrate.5. Do flush and clean lines regularly.6. Don't forget to clean & sanitize faucet seat cup7. Do follow all cleaning and sanitizing procedures. Remove and store tea concentrate if dispenser will not be used for an extended period of time (more than two days).

TROUBLESHOOTING GUIDE

SYMPTOM	POSSIBLE CAUSE	SOLUTION
Difficulty priming the TCC tea dispenser.	Adjusting rod on mixing valve is turned in too far.	Open up the valve 1/4 turn counter clockwise.
Tea does not dispense from faucet.	Water line is turned off.	Turn on water line valve.
Only water flowing from faucet, no tea.	1. Tea concentrate BIB is out of product.	1. Replace the tea concentrate BIB.
	2. The tea BIB line is kinked.	2. Trace the tea line and straighten out kinked hose.
	3. The tea BIB line is clogged.	3. Blow out hose to clean blockage or replace with a new hose.
	4. The check valve in the tea concentrate line may be stuck closed.	4. Loosen the clamps and remove the check valve. Clean or replace it.
	5. The adjustment screw may be turned in or closed.	5. Open the mixing valve to resume product flow.
Faucet is dripping constantly.	1. The faucet seat cup may have hardened particles keeping the faucet from sealing.	1. Disassemble and clean the seat cup (see cleaning section).
	2. There may be a tear or cut in the seat cup.	2. Replace the seat cup.
	3. Water pressure may be too high.	3. Call CURTIS CARE for instructions on adjusting the water regulator.
Finished tea is weak.	1. The mixing valve is out of adjustment.	1. Open the mixing valve to increase tea concentrate flow.
	2. The product check valve may be stuck.	2. Remove and clean the check valve. Make sure check valve is installed with correct flow direction.

TROUBLESHOOTING GUIDE

SYMPTOM	POSSIBLE CAUSE	SOLUTION
Product flowing from the faucet is too foamy or bubbly.	1. The clamps at the check valve may not be tight.	1. Reconnect tubing and tighten clamps.
	2. The clamp on the QCD connector may be loose.	2. Make sure the barbed end of the QCD fitting is pushed in on the hose and the clamp is tight.
	3. Tea concentrate product may have air in the BIB.	3. Turn the BIB so the fitting faces upward and open the faucet until all the bubbles are released.
	4. The O-ring on the QCD is worn out.	4. Replace the worn O-ring or install a new QCD.

Page Intentionally Left Blank

Product Warranty Information

The Wilbur Curtis Company certifies that its products are free from defects in material and workmanship under normal use. The following limited warranties and conditions apply:

2 Years, Parts, from Original Date of Purchase on all fittings and tubing.

1 Year, Labor, from Original Date of Purchase on all fittings and tubing.

Stainless Steel components are warranted for two (2) years from date of purchase against leaking or pitting and replacement parts are warranted for ninety (90) days from date of purchase or for the remainder of the limited warranty period of the equipment in which the component is installed.

All in-warranty service calls must have prior authorization. For Authorization, call the Technical Support Department at 1-800-995-0417. Effective date of this policy is April 1, 2003.

Additional conditions may apply. Go to www.wilburcurtis.com to view the full product warranty information.

CONDITIONS & EXCEPTIONS

The warranty covers original equipment at time of purchase only. The Wilbur Curtis Company, Inc., assumes no responsibility for substitute replacement parts installed on Curtis equipment that have not been purchased from the Wilbur Curtis Company, Inc. The Wilbur Curtis Company will not accept any responsibility if the following conditions are not met. The warranty does not cover and is void under the following circumstances:

- 1) **Improper operation of equipment:** *The equipment must be used for its designed and intended purpose and function.*
- 2) **Improper installation of equipment:** *This equipment must be installed by a professional technician and must comply with all local electrical, mechanical and plumbing codes.*
- 3) **Improper voltage:** *Equipment must be installed at the voltage stated on the serial plate supplied with this equipment.*
- 4) **Improper water supply:** *This includes, but is not limited to, excessive or low water pressure, and inadequate or fluctuating water flow rate.*
- 5) **Adjustments and cleaning:** *The resetting of safety thermostats and circuit breakers, programming and temperature adjustments are the responsibility of the equipment owner. The owner is responsible for proper cleaning and regular maintenance of this equipment.*
- 6) **Damaged in transit:** *Equipment damaged in transit is the responsibility of the freight company and a claim should be made with the carrier.*
- 7) **Abuse or neglect (including failure to periodically clean or remove lime accumulations):** *The manufacturer is not responsible for variation in equipment operation due to excessive lime or local water conditions. The equipment must be maintained according to the manufacturer's recommendations.*
- 8) **Replacement of items subject to normal use and wear:** *This shall include, but is not limited to, light bulbs, shear disks, "O" rings, gaskets, silicone tube, canister assemblies, whipper chambers and plates, mixing bowls, agitation assemblies and whipper propellers.*
- 9) **Repairs and/or Replacements** *are subject to our decision that the workmanship or parts were faulty and the defects showed up under normal use. All labor shall be performed during regular working hours. Overtime charges are the responsibility of the owner. Charges incurred by delays, waiting time, or operating restrictions that hinder the service technician's ability to perform service is the responsibility of the owner of the equipment. This includes institutional and correctional facilities. The Wilbur Curtis Company will allow up to 100 miles, round trip, per in-warranty service call.*

RETURN MERCHANDISE AUTHORIZATION: *All claims under this warranty must be submitted to the Wilbur Curtis Company Technical Support Department prior to performing any repair work or return of this equipment to the factory. All returned equipment must be repackaged properly in the original carton. No units will be accepted if they are damaged in transit due to improper packaging. NO UNITS OR PARTS WILL BE ACCEPTED WITHOUT A RETURN MERCHANDISE AUTHORIZATION (RMA).*

RMA NUMBER MUST BE MARKED ON THE CARTON OR SHIPPING LABEL. All in-warranty service calls must be performed by an authorized service agent. Call the Wilbur Curtis Technical Support Department to find an agent near you.

7/23/12@12.5 . ECN 14129



WILBUR CURTIS CO., INC.

6913 Acco St., Montebello, CA 90640-5403 USA

Phone: 800/421-6150

◆ Fax: 323-837-2410

◆ Technical Service Phone: 800/995-0417 (M-F 5:30A - 4:00P PST)

◆ Web Site: www.wilburcurtis.com

◆ E-Mail: techsupport@wilburcurtis.com

FOR THE LATEST SPECIFICATION INFORMATION GO TO WWW.WILBURCURTIS.COM