

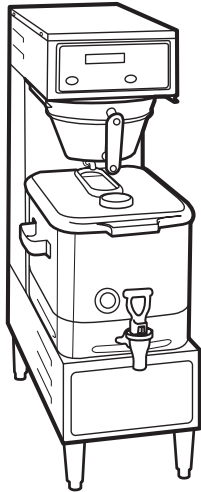

## Service Manual – TCT & PTT



Models Included:

- TCTS/T
- PTT3



**CAUTION:** Equipment must be installed to comply with applicable federal, state, and local plumbing/ electrical codes having jurisdiction.



**CAUTION:** Follow this setup procedure before attempting to use this unit. Failure to follow these instructions can result in injury and/or void of warranty.



**CAUTION:** DO NOT connect the unit to hot water. The inlet valve is not rated for hot water.



**IMPORTANT:** After setup, run a FULL brewcycle. Place a tea container to catch both hot water from the brewcone and dilution water from spout on the front cover.



**WARNING HOT LIQUID,** Scalding may occur. Avoid splashing.

ISO 9001:2008 REGISTERED

WILBUR CURTIS CO.  
Montebello, CA 90640  
For the latest information go to  
[www.wilburcurtis.com](http://www.wilburcurtis.com)  
Tel: 800/421-6150

### Important Safeguards/Symbols

This appliance is designed for commercial use. Any servicing other than cleaning and preventive maintenance should be performed by an authorized Wilbur Curtis service technician.

- Do NOT immerse the unit in water or any other liquid
- To reduce the risk of fire or electric shock, do NOT open service panels. No user serviceable parts inside.
- Keep hands and other items away from hot surfaces of unit during operation.
- Never clean with scouring powders, bleach or harsh chemicals.

### Symbols



WARNINGS – To help avoid personal injury



Important Notes/Cautions – from the factory



Sanitation Requirements

The Curtis G3 Brewer is Factory Pre-Set and Ready to Go... Right from the Box.

Following are the Factory Settings for the G3 Iced Tea Brewer.

- Brew Temperature = 204°F
- Brew Volume = Set to dispensing vessel requirements

Generally there will never be a reason to change the G3/Gold Cup Series default settings. However, should you need to make slight adjustments to meet your brewing needs, programming instructions are provided later in this manual.

System Requirements:

- Water Source 20 – 90 PSI. Minimum flow rate of ½ gpm (1 gpm preferred flow rate).
- Electrical: See electrical schematic on page 6.

### SETUP STEPS

The unit should be level (left to right and front to back), and located on a secure counter top. Connect a water line from the water filter to the brewer.

**NOTE:** A water filtration device must be used to maintain a trouble-free operation. (In areas with extremely hard water, we suggest that a sedimentary and taste & odor filter be installed.) This will prolong the life of your brewing system and enhance coffee quality.



NSF International requires the following water connection:

1. A quick disconnect or additional coiled tubing (at least 2x the depth of the unit) so that the machine can be moved for cleaning underneath.
2. In some areas an approved backflow prevention device may be required between the brewer and the water supply.
3. Water pipe connections and fixtures directly connected to a potable water supply shall be sized, installed and maintained in accordance with federal, state, and local codes.

1. A 1/4" Flare has been supplied for water line connection. Use tubing sized sufficiently to provide ½ GPM (preferred flow rate is 1gpm).
2. Connect the unit to an appropriate electrical power circuit.
3. Turn on the toggle (STANDBY/ON) switch behind the unit. The heating tank will start to fill. When the water level in the tank rises to the correct volume, the heating element will energize automatically. With G3 tea brewers there is no danger of element burnout caused by an empty tank.
4. The heating tank will require 20 to 30 minutes to reach operating temperature (204°F) as indicated by the READY-TO-BREW LCD readout.
5. Important: Run one full brewcycle, to purge the water lines and valves of air. Five seconds of dilution water at the beginning of each brewcycle is normal pre-programmed operating behavior.

### BREWING INSTRUCTIONS

1. Brewer should be ON (Confirm at rear toggle switch, then press ON/OFF button) and Ready-to-Brew displayed.
2. Place filter in brew basket. Pour leaf tea into basket.
3. Slide brew cone into brew rails. Place tea container under brew cone.
4. Press the BREW button to brew tea.

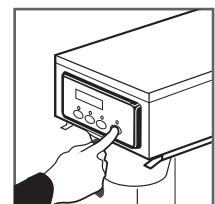
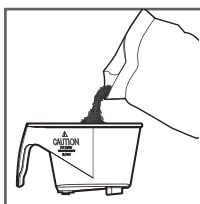



# Programming

## Quick Start

## TCT & PTT

Your Curtis Generation 3 Brewer is Factory Pre-Set for Optimum Performance.

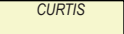
After connection to water and power; the rear toggle switch must be on. You will hear a beep sound, indicating power is available to the controller.

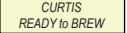

The control displays . Press ON/OFF button and the screen will display . After three seconds,  is displayed.

Water will fill the tank (approximately 2-3 minutes depending on water flow rate). When the proper level is reached  will appear on the screen. It takes approximately 20 minutes to reach set point temperature of 204°F.

Control will display  when temperature reaches the set point (204°F). Unit is now ready to brew.

### To Go Into Programming

Turn off (dark display) by pressing ON/OFF button (yellow). Press and hold BREW button (4) (green) and then press and release ON/OFF button (yellow).

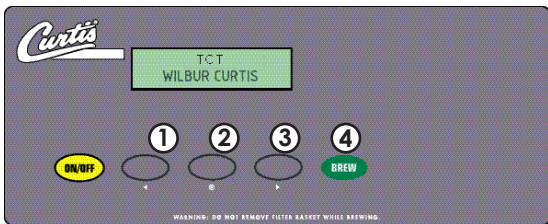

Continue holding BREW button. Display will read , wait until  is displayed. Enter the 4-digit access code, the digits 1-4 correspond to the buttons (see illustration below).

The default code set at the factory is 1-2-3-4. Then  will be displayed.



All programming selections are performed with the three center buttons.

The symbols below the buttons are:

-  Scroll LEFT
-  SELECTION or ENTER to save new parameter
-  Scroll RIGHT

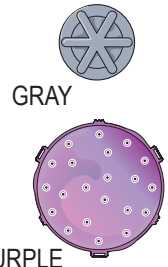

**SPRAYHEADS:** Mentioned in this Programming guide are the words Gray and Purple. This refers to the color of the sprayhead. The current sprayhead is the purple AFS. The older version is the gray sprayhead. See the illustration at right.

PURPLE

### Program Menus

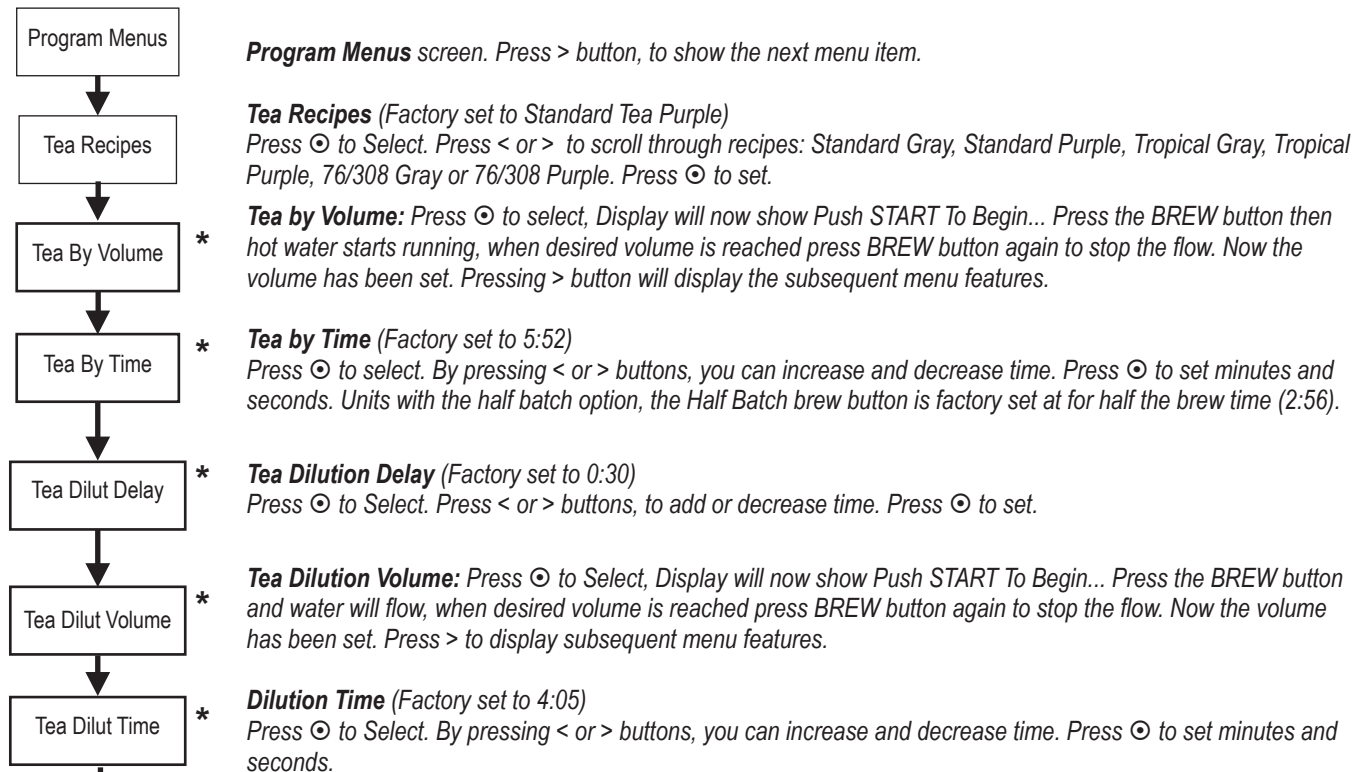

\* On units with the **half batch option**, the half batch brew button may be independently set.

# Programming

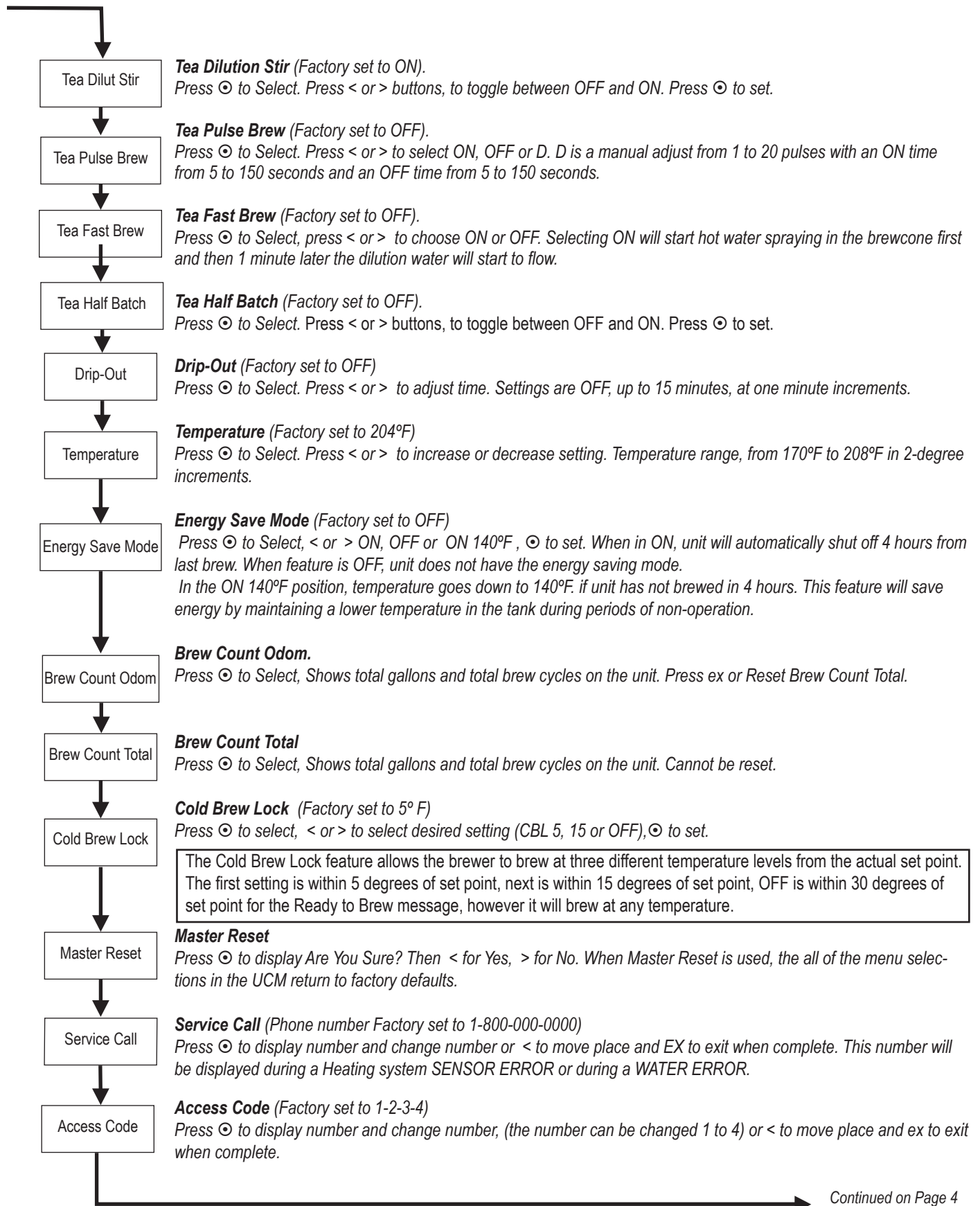

---

## Programming

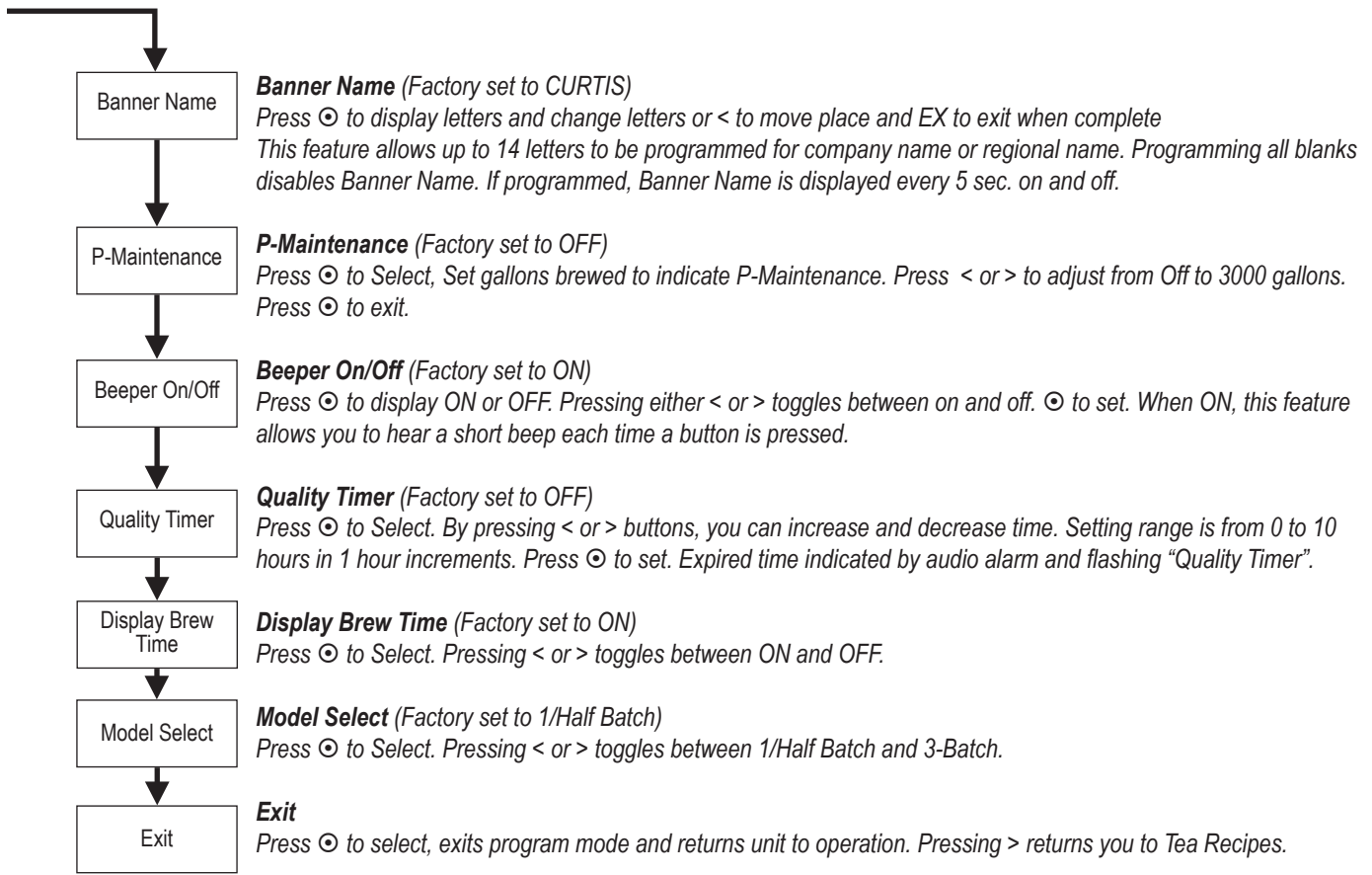

---

## Tank Temperature Check

Turn on brewer at the control panel ON/OFF button. Press and hold **③** button (see illustration, page 2) for 5 seconds. Water Temperature will be displayed (temperature in heating tank).

---

## Error Message

With G3/Gold Cup Series brewers, there are three error messages that can appear on the screen to advise the user of a malfunction. If one of these error messages appear, the brewer will lock up and stop functioning until the error is corrected.

An error message will occur under the following conditions:

- |                                   |  |
|-----------------------------------|--|
| (800) 000-000<br>Water Level Err  | 1. Water level fill error or overflow. This error message occurs when the inlet valve solenoid has been on for more than 10 minutes. This error message also occurs when the valve is refilling the tank during a brew cycle for more than 1½ minutes. |
| (800) 000-000<br>Sensor Err       | 2. Water temperature control system error. An open probe or a break in the temperature control circuit is detected.  |
| Place Container<br>Against Switch | 3. This error message indicates that the safety switch (centered on the front panel) was not pressed when the user was attempting to brew tea. The tea brewing container must be pushed back against the switch to allow brewing to continue.          |
- The screen may display a phone number to call for service. After the malfunction is corrected, the error message must be cleared. To reset the control panel and return to normal operation, press **⊙** for 5 seconds.

# Illustrated Parts TCT

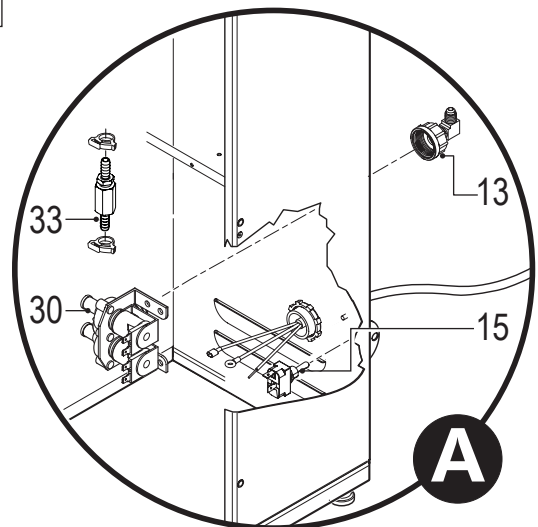
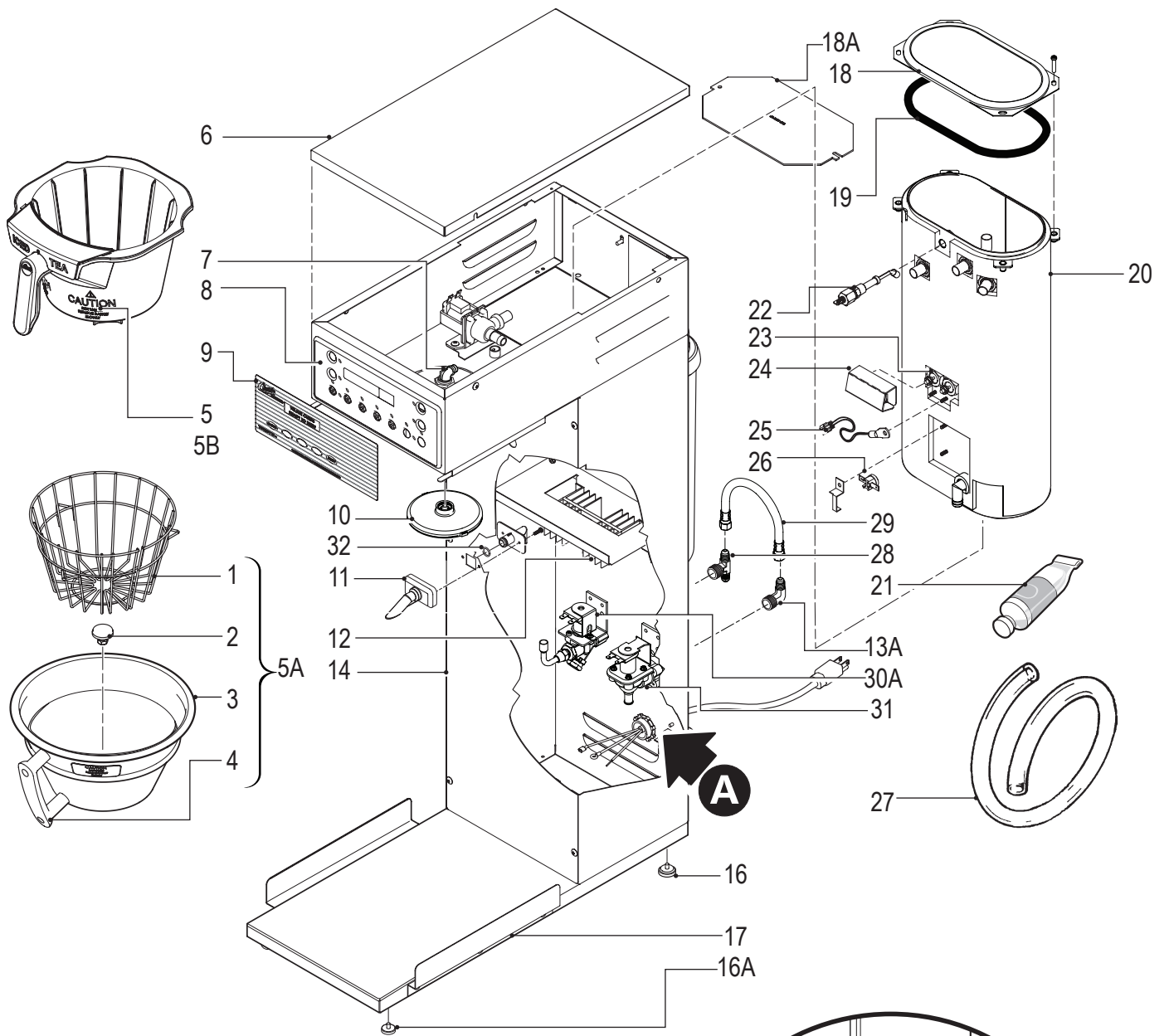

## PARTS LIST

ITEM	PART N°	DESCRIPTION
1	WC-3301	BASKET, WIRE 7.00 DIA. USE WITH WC-3311 (OPTNL)
2	WC-3647	STRAINER BT-10 BREWCONE (EXCEPT PARADISE)
2A	WC-8532	STRAINER, TROPICAL BREWCONE
3	WC-3320	BREW CONE W/HANDLE 8.8" D W/STRNR (OPTIONAL)
4	WC-3201	HANDLE, BREW CONE BLACK FOR WC-3320
5	WC-3398	BREW CONE, ASSY STD TEA NON-METAL W/BLU GUARD
5A	WC-3358	BREWCONE W/WC-3320, WC-3301 & WC-3647 (OPTNL)
5B	WC-3399	BREW CONE, ASSY TROPICAL TEA NON-MTL W/YEL GUARD
6	WC-58117	COVER, TOP BREWER
7	WC-2977-01	FITTING ASSY, SPRAYHEAD W/O-RING
8	WC-37189*	UCM KIT, LABEL & OVERLAY 120V TCTS/T
8A	WC-37338	KIT, UCM & OVERLAY W/HALF BATCH BREW TCTS
9	WC-39398*	LABEL, UCM PANEL TCT/PTT GT3 W/O FAUCET CURTIS
9A	WC-39628	LABEL, UCM PANEL W/HALF BATCH W/O FAUCET
10	WC-29025*	SPRAYHEAD, PURPLE ADVANCE FLOW
10A	WC-2942	SPRAYHEAD, GRAY (OLDER UNITS)
11	WC-66079	SPOUT ASSY , DILUTION PLASTIC
11A	WC-2965	SPOUT, BYPASS ASSEMBLY
12	WC-8556*	HEAT SINK ASSY DV
13	WC-37255	KIT, DUAL VALVE WATER INLET
13A	WC-2401	ELBOW, 3/8 NPT X 1/4 FLARE PLATED
14	WC-58017-104	COVER, FRONT TCTS
14A	WC-58021-103	COVER, FRONT CENTER WRAP TCTT
14B	WC-58101-102	COVER, CENTER WRAP PTT3
14C	WC-58017	COVER, CENTER WRAP TCT-35S TCTDP-35S (OLDER UNITS)
14D	WC-58021	COVER, FRONT CENTER WRAP TCTT/TCTD-35S (OLDER UNITS)
14E	WC-58101	COVER, CENTER WRAP SS PTT3 (OLDER UNITS)
15	WC- 102*	SWITCH, TOGGLE SPST 25A 125/250VAC RESISTIVE
16	WC-3518	LEG, GLIDE 3/8"-16 STUD SCREW
16A	WC-3503	LEG, 8-32 STD SCREW BUMPER
17	WC-8531	RAIL, BASE TCTD
18	WC-5853-102	COVER, TOP HEATING TANK GEN USE
18A	WC-5851	COVER, TANK W NOTCHES (OLDER UNITS)
19	WC-43062	GASKET, TANK LID
20	WC-6277	TANK ASSY, COMPLETE TEA BREWER
21	WC-5231*	COMPOUND SILICONE 5 OZ
22	WC-5502-01*	KIT, PROBE, ASSY WATER LEVEL W/HEX FITTING, O-RING & NUT
23	WC- 904-04*	ELEMENT, HEATING 1.6KW 120V W/JAM NUTS
24	WC-4394	SHOCK GUARD, HEATING ELEMENT
25	WC-1438-101*	SENSOR, TEMPERATURE TANK
26	WC- 523*	THERMOSTAT, MANUAL RESET 120/220V 25A 220°F MAX
27	WC-5310*	TUBING, 5/16" ID X 1/8" W SILICONE
28	WC-2707	TEE, FLARE 1/4 x 1/4 x 3/8 BRASS
29	WC-53038	TUBE ASSY, FLEXIBLE 1/4 FLARE 11-1/8"
30	WC- 826L*	VALVE, INLET 1 GPM 120V 10W
31	WC- 895-105	VALVE, INLET DUAL 120V 10W 2 GPM X .5 GPM
31A	WC- 801*	VALVE, INLET BRASS .50 GPM 120V 10W RU/WB (OLDER UNITS)
32	WC-43134	O'RING, .426 X 9/16 O.D X .070 WALL EDPM TCTS
33	WC- 810-103	VALVE, CHECK 3/8 X 3/8 BARB SS WITH O-RING & .010 SPRING

\* RECOMMENDED PARTS TO STOCK

# Illustrated Parts List

## TCO

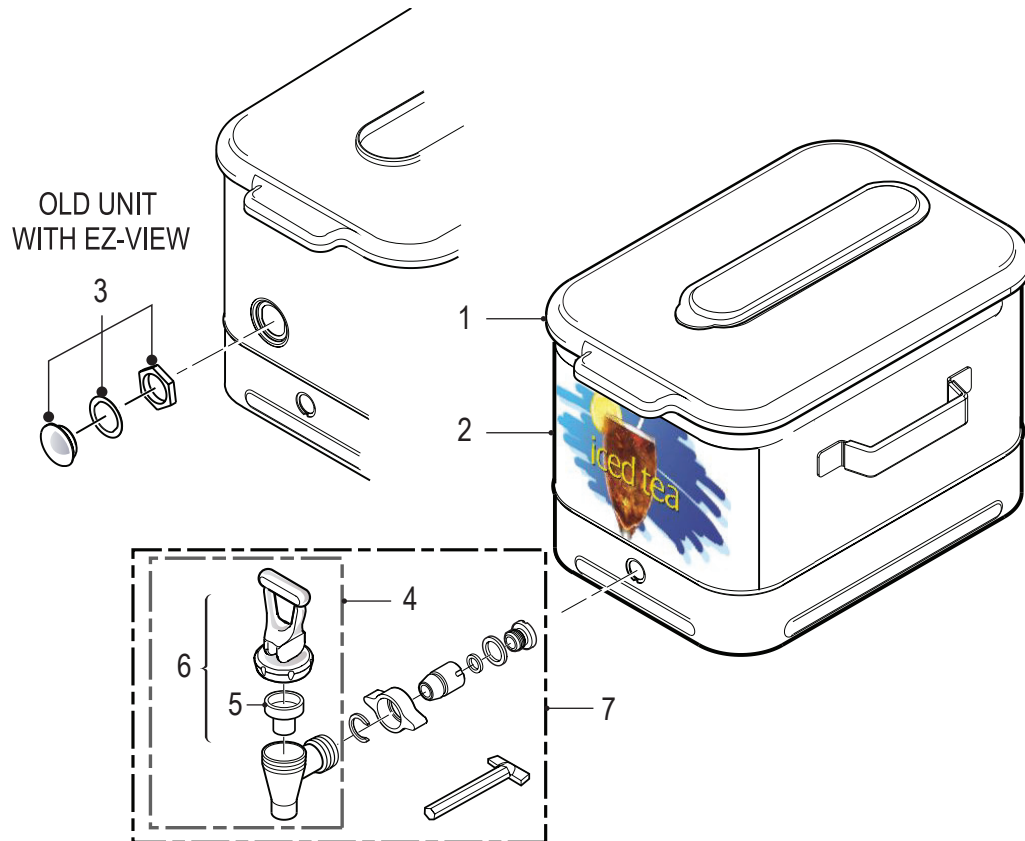

ITEM	PART N°	DESCRIPTION
1	WC-5683	LID ASSY, TCO
2	WC-38471	LABEL, FRONT ICED TEA GENERIC
3	WC-3724*	KIT, EZ-VIEW REPLACEMENT (OLDER UNITS)
4	WC-1803	FAUCET, SPB
5	WC-1805*	SEAT CUP, FAUCET S'
6	WC-3707*	KIT, REPAIR SPB FAUCET
7	WC-37260*	KIT, FAUCET W/ADAPTER COMPLETE

\* RECOMMENDED PARTS TO STOCK

**Illustrated Parts List  
TCN**

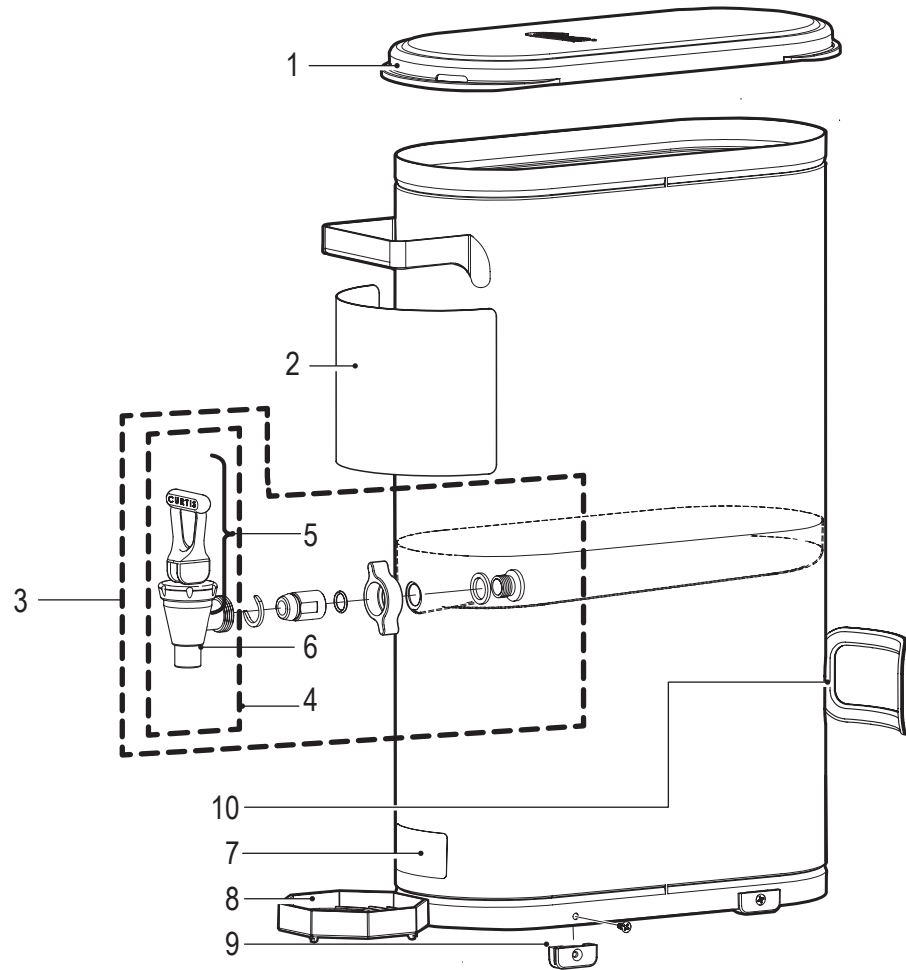

ITEM	PART N°	DESCRIPTION
1	WC-61436	LID, BLACK PLASTIC TCN
2	WC-38471	LABEL, FRONT TCN GENERIC
3	WC-1803*	FAUCET, SPB
4	WC-37260	KIT, FAUCET W/ADAPTER COMPLETE
5	WC-3707*	KIT, REPAIR SPB FAUCET
6	WC-1805*	SEAT CUP, FAUCET S'
7	WC-38163	LABEL, CURTIS SWP CLR/WHT
8	WC-5686	DRIP TRAY, OCTAGON STYLE
9	WC-3531*	LEG, PLASTIC GLIDE TCN
10	WC-3289	HANDLE, GASKET

\* RECOMMENDED PARTS TO STOCK



# TCT ELECTRICAL SCHEMATIC

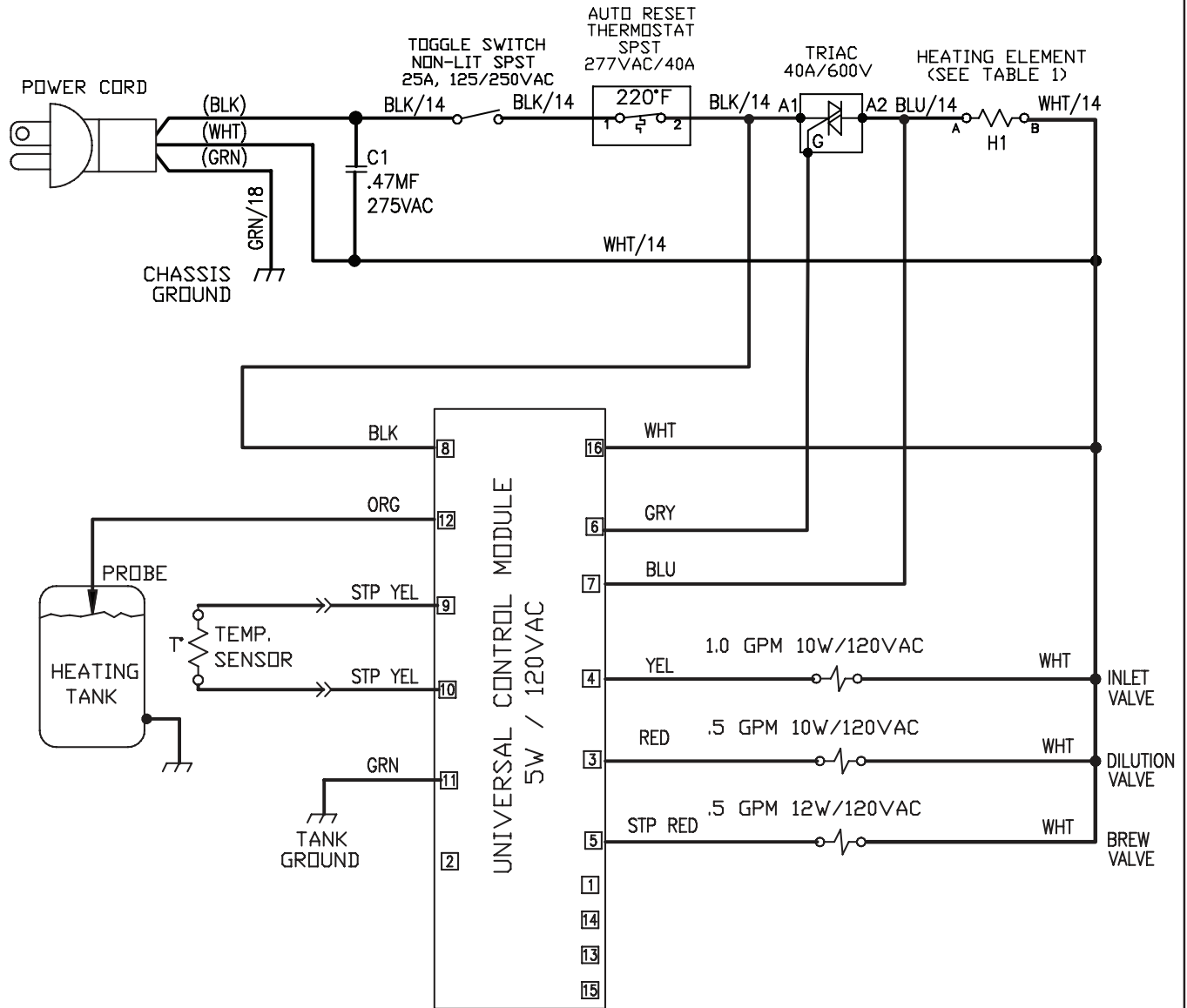

PIN ASSIGNMENTS	
PIN 01:	NOT USED
PIN 02:	NOT USED
PIN 03:	DILUTION VALVE
PIN 04:	INLET VALVE / TANK
PIN 05:	BREW VALVE
PIN 06:	TRIAC GATE
PIN 07:	TRIAC A2
PIN 08:	120VAC HOT
PIN 09:	TEMP SENSOR
PIN 10:	TEMP SENSOR
PIN 11:	GROUND
PIN 12:	WATER LEVEL PROBE
PIN 13:	NOT USED
PIN 14:	NOT USED
PIN 15:	NOT USED
PIN 16:	120VAC NEUTRAL

ELECTRICAL RATING TABLE 1

MACHINE	HEATING ELEMENTS	TOTAL POWER (WATTS)	TOTAL CURRENT (AMPERES)
(SC)TCTS/T-10 PIT3-10	1600W 120VAC	1650W	13.8A
(SC)TCTS/T-20 PIT3-20	1450W 120VAC	1500W	12.5A

TRIAC PIN ASSIGNMENTS

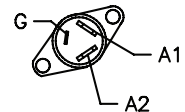

VOLTAGE:	120VAC
WATTAGE:	SEE TABLE 1
AMPERAGE:	SEE TABLE 1
HERTZ:	50/60
WIRES:	2W+G
PHASE:	1PH

2. USE THIS DIAGRAM FOR ALL OTHER MODELS WITH ADDED PREFIX LETTERS AND/OR DIFFERENT DASH NUMBER ON THEIR PART NUMBERS HAVING THE SAME ELECTRICAL RATINGS.  
EX: TCTS10000

1. ALL WIRES SHALL BE 18 AWG PVC COATED.  
NOTES: UNLESS OTHERWISE SPECIFIED

TITLE:	LADDER DIAGRAM	
PART NUMBER:	LD-TCT-10	REVISION:
		H

## TEA TIPS



**WARNING** DO NOT refrigerate unused tea overnight for later consumption.

## CLEANING



**IMPORTANT:** If the brew cone comes with a screen; clean the screen to maintain the tea flow. Neglecting this screen will eventually cause the brewcone to overflow, spilling hot liquid over the unit.



**CAUTION:** DO NOT use undiluted bleach or chlorine.

1. Store tea bags in a dark, cool and dry place away from strong odors and moisture. Do not refrigerate.
2. Never hold finished brewed tea for more than eight hours at room temperature. Discard any unused tea after eight hours
3. Brew only enough tea that you reasonably expect to serve within a few hours.
4. To protect tea flavor and to avoid bacterial contamination and growth, clean and sanitize tea brewing, storage and dispensing equipment at least once a day.

Regular cleaning of your airpots and tea containers will maintain the highest quality coffee and iced tea your equipment is capable of producing. A proper cleaning is essential in preserving the appearance of the brewer.

1. Turn off the tea brewer at the ON/OFF button on the front control panel.
2. Wipe exterior surfaces with a damp cloth, removing spills and debris.
3. Slide the brewcone out and clean it. Thoroughly soap the sprayhead area with a mild detergent solution.
4. Wash the brewcone and wire brew basket, if applicable. Use a soft bristled brush for hard to clean areas. Wash both parts with a detergent solution or put these parts through a dishwasher.
5. Wash the tea container and top cover. Use a detergent solution and a soft bristled brush to clean inside the container. Wipe the exterior surfaces with a sponge and detergent solution. Rinse thoroughly.
6. Clean the faucet assembly. Unscrew the handle assembly from the faucet and remove. Clean the faucet shank with a gage glass brush (circular bristle) by pushing the brush through the shank. Using the same brush clean the faucet body inlet and outlet. Clean the faucet cap and silicone seat cup.
7. After the cleaning, place the parts (sprayhead, brewcone and basket and faucet parts) into a sink to be sanitized.  
To sanitize the disassembled parts:
  - A. Use a clean container to submerge all parts. Wear rubber gloves for protection.
  - B. Immerse in commercial Bar Tabs/Sani-Tabs sanitizing solution The solution must be warm (75°F.) Let the parts soak for at least one minute.
8. Thoroughly rinse parts with hot water. Air dry, all parts that were sanitized.
9. After cleaning, sanitizing and drying, assemble any parts taken from the tea container.
10. Clean out airpots with a sponge brush and a mild detergent solution. To remove mineral deposits, fill liner with vinegar and allow to soak.

Cleaning intervals for the probe are to be determined by the user or the service tech based on water conditions. The use of water filters, or the type of water filter that is being used can impact the service interval. Intervals can be from one month to several years, however, replacing rather than cleaning the probe is preferable.



**WARNING:** Disconnect electrical power before removing access panels.



**CAUTION:** This procedure involves working with hot water and hot surfaces.

1. Unplug the power cord and shut off the water line.
2. Remove the top cover of the unit. Locate the top of the tank and remove the cover.
3. Drain the tank to a level about 3" below the tip of the probe.
4. Allow some time for the probe to cool before working on the brewer.
5. Clean the tip of the probe using a Scotch-Brite™ scuff pad.
6. If a residual white layer is still visible on the probe, remove the probe and soak it in vinegar or a scale removing chemical. Repeat this step until the white layer is removed.



## LIQUID LEVEL PROBE

## TCT ROUGH-IN DRAWING

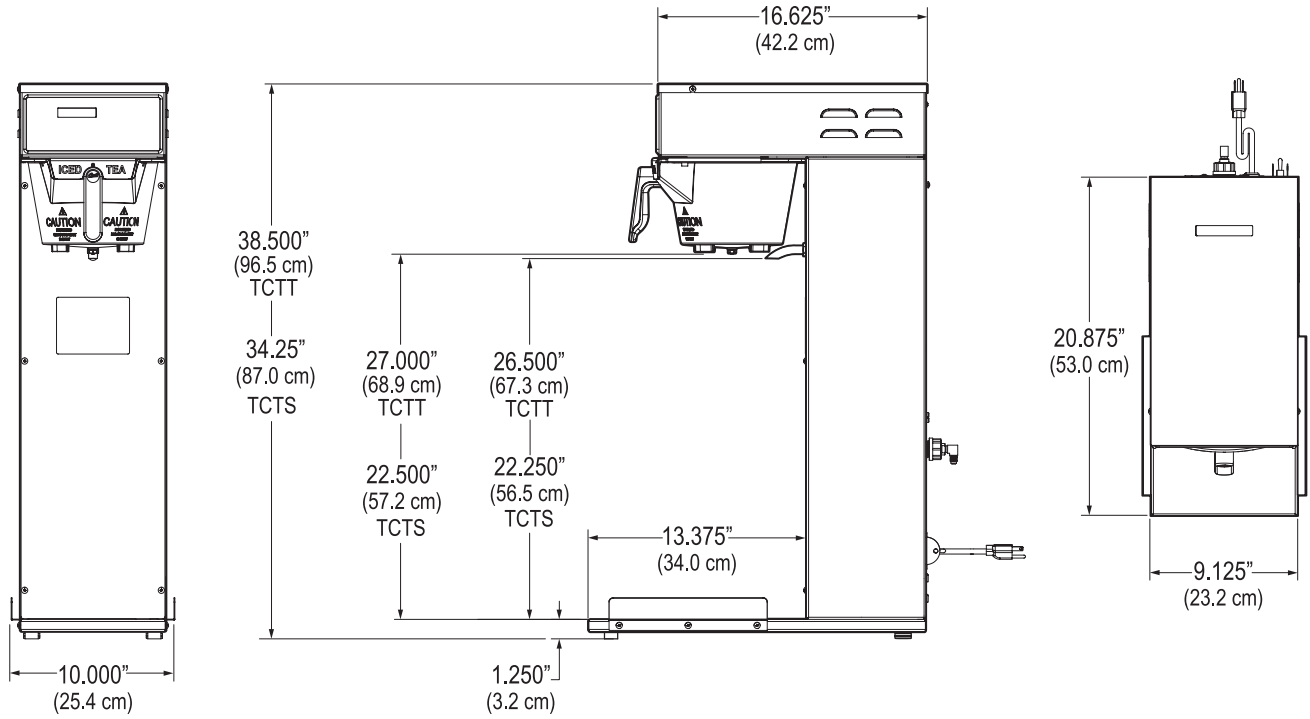

## PTT ROUGH-IN DRAWING

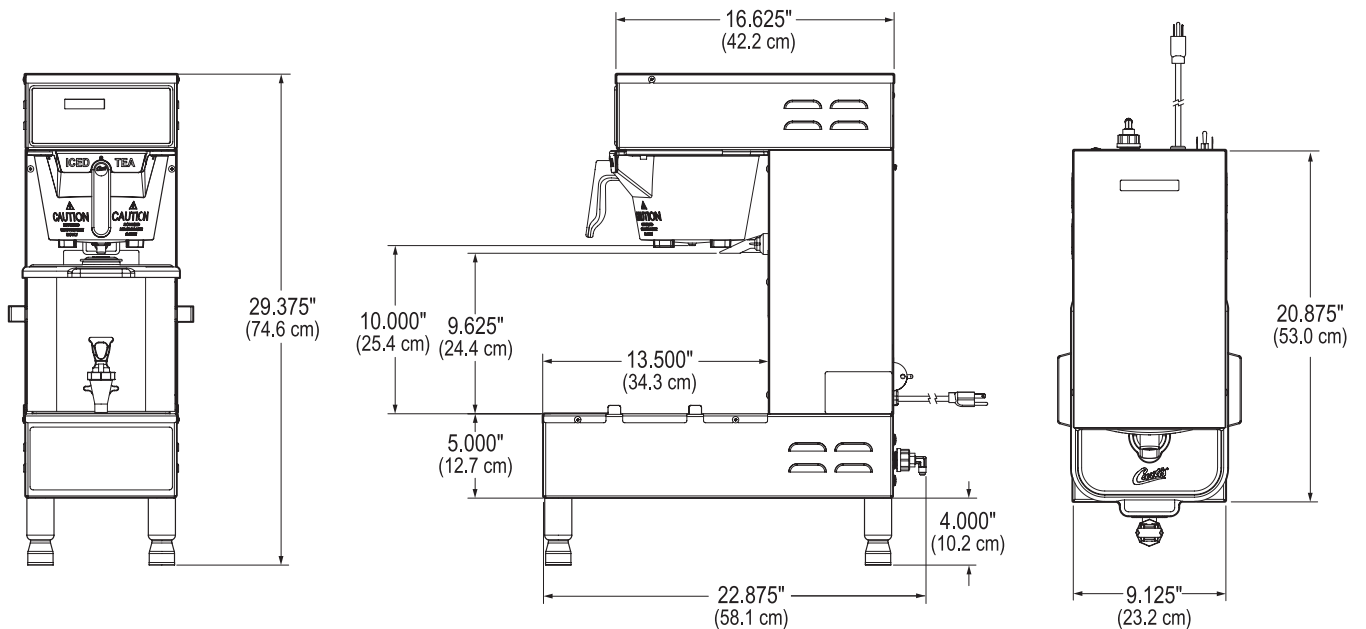

## Product Warranty Information

The Wilbur Curtis Company certifies that its products are free from defects in material and workmanship under normal use. The following limited warranties and conditions apply:

3 Years, Parts and Labor, from Original Date of Purchase on digital control boards.

2 Years, Parts, from Original Date of Purchase on all other electrical components, fittings and tubing.

1 Year, Labor, from Original Date of Purchase on all electrical components, fittings and tubing.

Additionally, the Wilbur Curtis Company warrants its Grinding Burrs for Forty (40) months from date of purchase or 40,000 pounds of coffee, whichever comes first. Stainless Steel components are warranted for two (2) years from date of purchase against leaking or pitting and replacement parts are warranted for ninety (90) days from date of purchase or for the remainder of the limited warranty period of the equipment in which the component is installed.

All in-warranty service calls must have prior authorization. For Authorization, call the Technical Support Department at 1-800-995-0417. Effective date of this policy is April 1, 2003.

Additional conditions may apply. Go to [www.wilburcurtis.com](http://www.wilburcurtis.com) to view the full product warranty information.

### CONDITIONS & EXCEPTIONS

The warranty covers original equipment at time of purchase only. The Wilbur Curtis Company, Inc., assumes no responsibility for substitute replacement parts installed on Curtis equipment that have not been purchased from the Wilbur Curtis Company, Inc. The Wilbur Curtis Company will not accept any responsibility if the following conditions are not met. The warranty does not cover and is void under the following circumstances:

- 1) Improper operation of equipment: The equipment must be used for its designed and intended purpose and function.
- 2) Improper installation of equipment: This equipment must be installed by a professional technician and must comply with all local electrical, mechanical and plumbing codes.
- 3) Improper voltage: Equipment must be installed at the voltage stated on the serial plate supplied with this equipment.
- 4) Improper water supply: This includes, but is not limited to, excessive or low water pressure, and inadequate or fluctuating water flow rate.
- 5) Adjustments and cleaning: The resetting of safety thermostats and circuit breakers, programming and temperature adjustments are the responsibility of the equipment owner. The owner is responsible for proper cleaning and regular maintenance of this equipment.
- 6) Damaged in transit: Equipment damaged in transit is the responsibility of the freight company and a claim should be made with the carrier.
- 7) Abuse or neglect (including failure to periodically clean or remove lime accumulations): Manufacturer is not responsible for variation in equipment operation due to excessive lime or local water conditions. The equipment must be maintained according to the manufacturer's recommendations.
- 8) Replacement of items subject to normal use and wear: This shall include, but is not limited to, light bulbs, shear disks, "O" rings, gaskets, silicone tube, canister assemblies, whipper chambers and plates, mixing bowls, agitation assemblies and whipper propellers.
- 9) Repairs and/or Replacements are subject to our decision that the workmanship or parts were faulty and the defects showed up under normal use. All labor shall be performed during regular working hours. Overtime charges are the responsibility of the owner. Charges incurred by delays, waiting time, or operating restrictions that hinder the service technician's ability to perform service is the responsibility of the owner of the equipment. This includes institutional and correctional facilities. The Wilbur Curtis Company will allow up to 100 miles, round trip, per in-warranty service call.

**RETURN MERCHANDISE AUTHORIZATION:** All claims under this warranty must be submitted to the Wilbur Curtis Company Technical Support Department prior to performing any repair work or return of this equipment to the factory. All returned equipment must be repackaged properly in the original carton. No units will be accepted if they are damaged in transit due to improper packaging. **NO UNITS OR PARTS WILL BE ACCEPTED WITHOUT A RETURN MERCHANDISE AUTHORIZATION (RMA). RMA NUMBER MUST BE MARKED ON THE CARTON OR SHIPPING LABEL.** All in-warranty service calls must be performed by an authorized service agent. Call the Wilbur Curtis Technical Support Department to find an agent near you.

Rev R . ECN 14359 . 8/21/12@9.5



**WILBUR CURTIS CO., INC.**

6913 Acco St., Montebello, CA 90640-5403 USA

Phone: 800/421-6150 ♦ Fax: 323-837-2410

♦ Technical Support Phone: 800/995-0417 (M-F 5:30A - 4:00P PST) ♦ E-Mail: [techsupport@wilburcurtis.com](mailto:techsupport@wilburcurtis.com)

♦ Web Site: [www.wilburcurtis.com](http://www.wilburcurtis.com)

**FOR THE LATEST SPECIFICATION INFORMATION GO TO [WWW.WILBURCURTIS.COM](http://WWW.WILBURCURTIS.COM)**