



# MACCHINE DA CAFFE' AUTOMATICA AUTOMATIC COFFEE MACHINES

De' Longhi PERFECTA ESAM 5500  
(INT / AUS - NZ / GB)

## DATI TECNICI / TECHNICAL DATA / TECHNISCHE DATEN DONNEES TECHNIQUES / DATOS TECNICOS

---

Voltaggio / Voltage / Spannung / Voltage / Voltaje	V / Hz 220 - 240 / 50 - 60
--	----------------------------

---

Max. potenza assorbita / Max. input power	W 1350
---	--------

---

## SEZIONE CAFFE' / COFFEE SECTION

---

Sonda termica / Temperature probe	°C 98 (Caffè / Coffee)
	°C 98 (Acqua calda / Hot water)

---

Fusibile termico TCO / Thermal fuseTCO	°C 192
--	--------

---

Resistenza riscaldamento	W 600 + 600
--------------------------	-------------

---

Pompa / Pump	TYPE / W ULKA EP5 / 48
--------------	------------------------

---

## SEZIONE VAPORE / STEAM SECTION

---

Sonda termica / Temperature probe	°C 145 (Vapore / Steam)
-----------------------------------	-------------------------

---

Fusibile termico TCO / Thermal fuseTCO / Thermische-Sicherung TCO Fusible thermique TCO / Fusible térmico TCO	°C 318
--	--------

---

Resistenza riscaldamento / Heating element / Heizelement Elément chauffant / Resistencia de calefacción	W 1000
--	--------

---

SCHEMA ELETTRICO / ELECTRICAL DIAGRAM

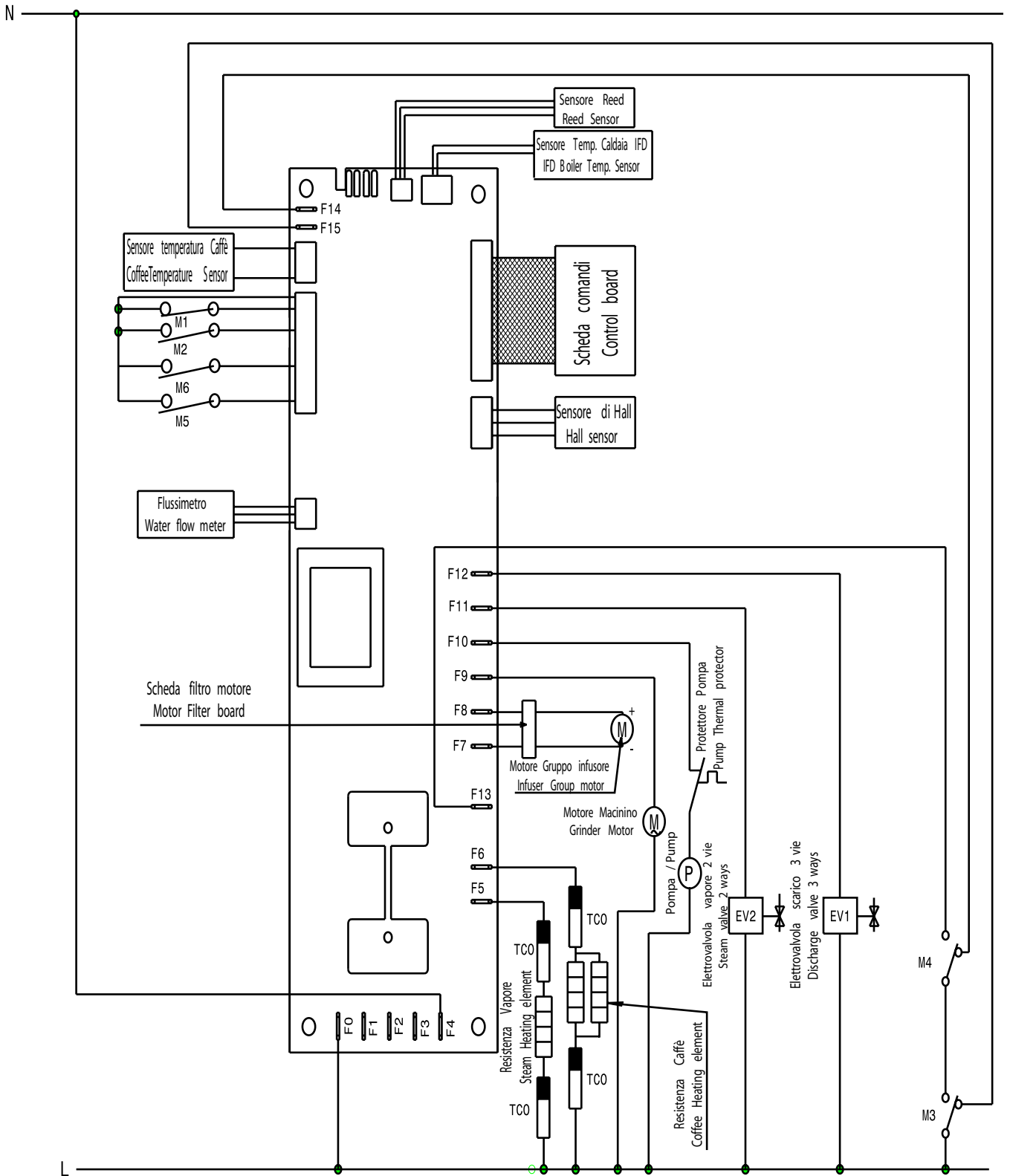

# SCHEMA ELETTRICO / ELECTRICAL DIAGRAM

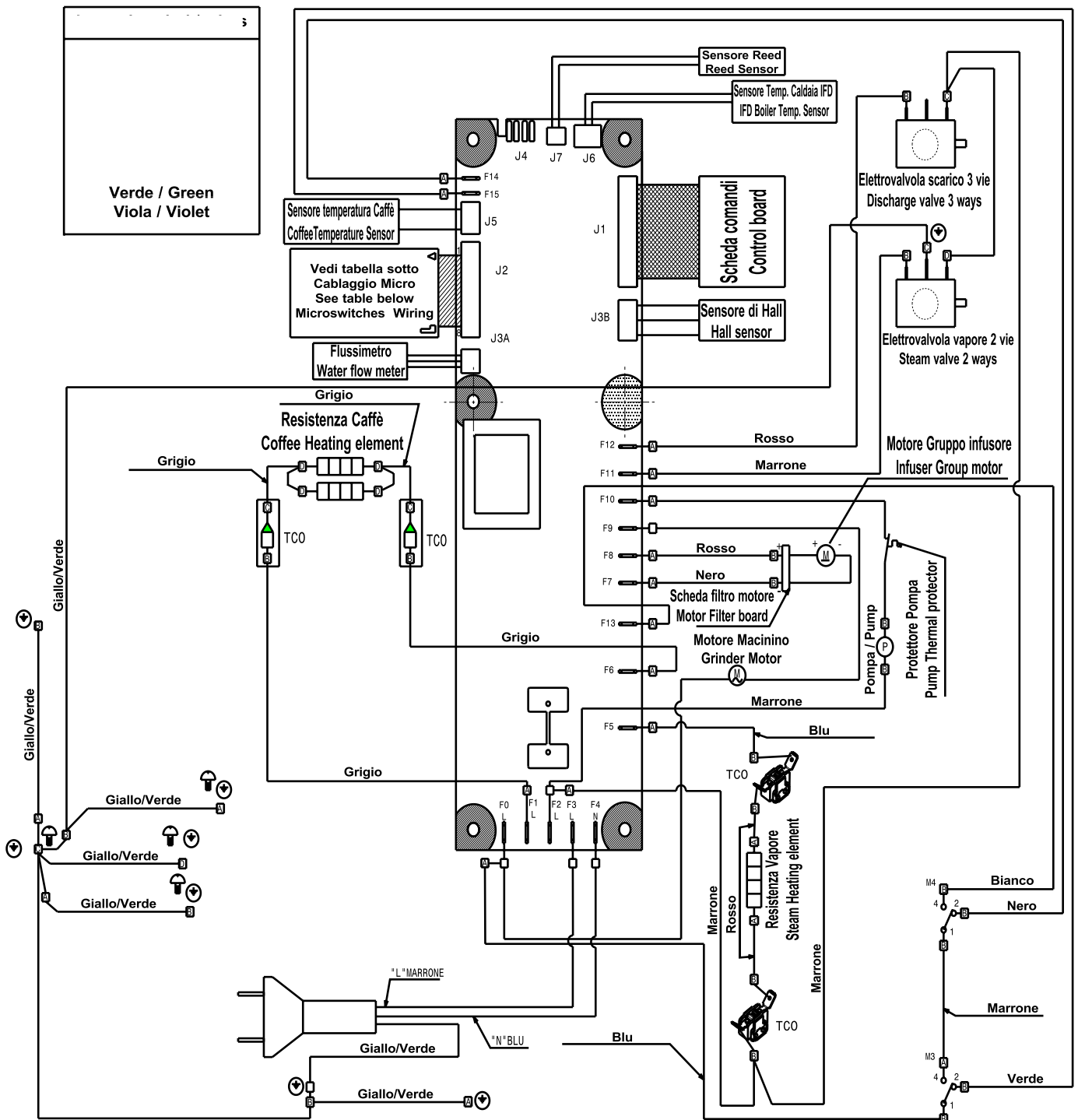

## Legenda Micro / Microswitches

M1	Infusore alto / Infuser top position
M2	Infusore basso / Infuser bottom position
M3	Cassetto fondi / Coffee grounds container
M4	Portina Service / Service Door
M5	Presenza dispositivo IFD / IFD device in place
M6	Presenza erogatore acqua calda / Hot water spout in place

## Cablaggio Micro / Microswitches Wiring

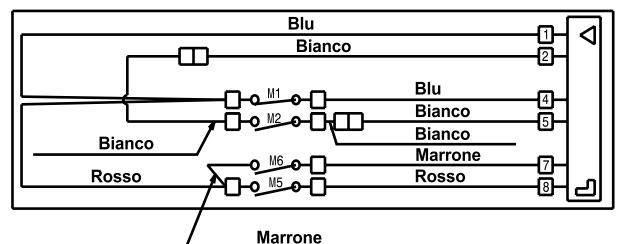



To enter the procedure:

Press and hold: 1 Coffee + Hot water buttons  
then plug the machine On

- . Pressing ON / OFF button: EV1 + EV2 ON
- . Pressing "P" button: Coffee boiler ON ("HEATER ON")
- . Pressing "Rinsing" button: Grinder ON
- . Pressing "Coffee taste" button: EV2 ON
- . Pressing "Cappuccino" button: Steam boiler ON ("VAPORIZER ON")
- . Pressing One Cup button: EV1 ON
- . Pressing Two Cups button: MOTOR UP, till "LIMIT SWITCH UP",  
then "MOTOR DOWN", till "LIMIT SWITCH DOWN".
- . Pressing "Hot Water" button: Water pump ON

**NOTE: statistic procedure is available throught the user MENU.**

To EXIT the procedure, unplug the machine.



## DYSPLAY TEST PROCEDURE FOR ESAM5500 Perfecta



To enter the DISPLAY Test:  
Press and Hold: 2 Cups + Hot water buttons  
then plug the machine On

. Pressing each single button the display  
will show the number of the button.  
Turning the knob, the display will show the bar increasing or decreasing.

Note: after performing this procedure, the machine has to be  
initialized again: set language and priming the water cycle.

**NOTE: statistic procedure is available throught the user MENU.**

To EXIT the procedure, unplug the machine.



Per entrare nella procedura:

tenere premuti contemporaneamente i tasti  
"1 tazza" + "acqua calda" e inserire la spina.

- . Premendo il tasto ON / OFF: elettrovalvole ON (EV1 + EV2 ON),
- . Premendo il tasto "P": Caldaia caffè ON (HEATER ON),
- . Premendo il tasto "Risciacquo": macinino ON "(GRINDER ON),
- . Premendo il tasto "Gusto caffè": elettrovalvola EV2 ON (EV2 ON),
- . Premendo il tasto "Cappuccino": caldaia vapore ON (VAPORIZER ON),
- . Premendo il tasto "1 tazza": elettrovalvola EV1 ON (EV1 ON),
- . Premendo il tasto "2 tazze": si alimenta il motore in salita (MOTOR UP),  
finchè raggiunge il finecorsa superiore (LIMIT SWITCH UP),  
tenendo sempre premuto il motore cambia direzione e scende  
(MOTOR DOWN), finchè raggiunge il finecorsa inferiore (LIMIT SWITCH  
DOWN) e poi si ferma.
- . Premendo il tasto "Acqua calda": si alimenta la pompa.

**NB: alla funzione statistica si accede dal menù utente.**

Per uscire dalla procedura, staccare la spina



Per entrare nella procedura:

tenere premuti contemporaneamente i tasti  
"2 tazze" + "acqua calda" e inserire la spina

Premendo ciascun tasto sul display comparirà il numero corrispondente.

Ruotando la manopola, si incrementa o decrementa la barra a LED.

**NB: alla funzione statistica si accede dal menù utente.**