

BUNN®

DG-2 *WDG-2*

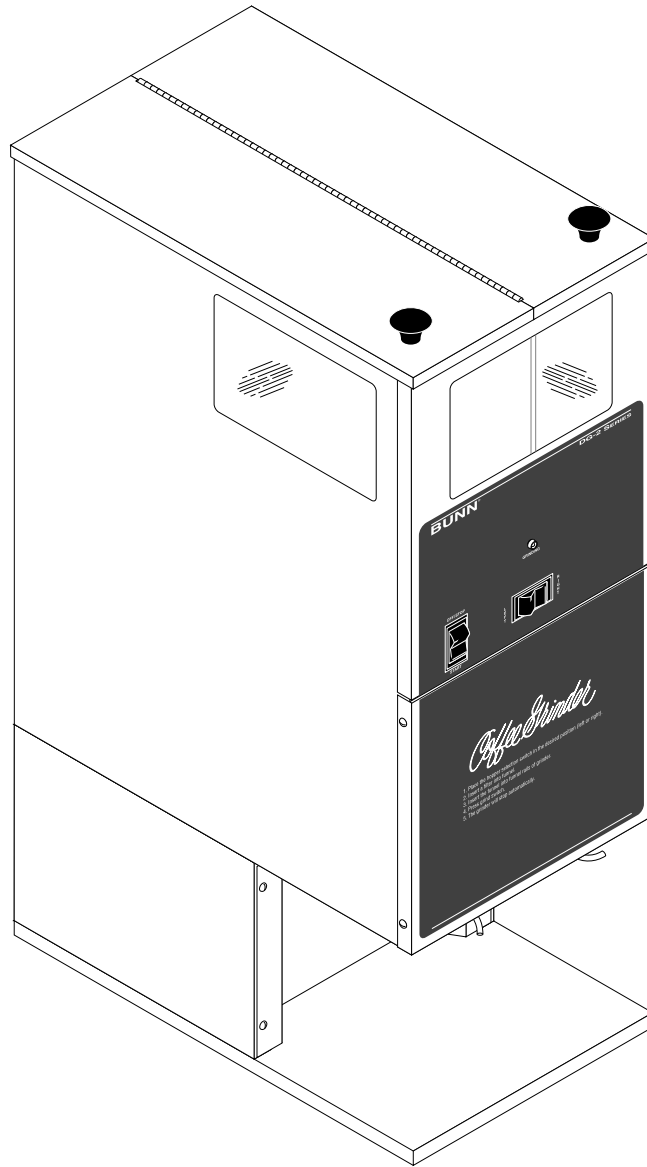

INSTALLATION & OPERATING MANUAL

BUNN-O-MATIC CORPORATION

POST OFFICE BOX 3227

SPRINGFIELD, ILLINOIS 62708-3227

PHONE: (217) 529-6601 FAX: (217) 529-6644

CONTENTS

Introduction	2
Warranty	2
User Notices	3
Electrical Requirements	4
Operating Controls	4
Initial Set-Up	5
Cleaning	6
Coffee Grinding	6
Adjustments	7
Trouble Shooting	9
Service	12 thru 23
Wiring Diagrams	24,25

INTRODUCTION

This equipment will store up-to six pounds of whole bean coffee in each of two hoppers and grind it to a preset grind and amount into an awaiting funnel and filter from most commercial drip coffee brewers. The equipment is only for indoor use on a sturdy counter or shelf. Adequate space must be available above the grinder to raise the lids when adding beans. Use only with whole bean coffee.

The grind is preset at the factory to **drip** specifications as set forth by the United States Department of Commerce and adopted by the Coffee Brewing Center of the Pan American Coffee Bureau. Adjustments may be made to alter both the amount and grind from the factory setting.

WARRANTY

Bunn-O-Matic Corp. ("Bunn") warrants the equipment manufactured by it to be commercially free from defects in material and workmanship existing at the time of manufacture and appearing within one year from the date of installation. In addition:

- 1.) Bunn warrants electronic circuit and/or control boards to be commercially free from defects in material and workmanship for two years from the date of installation.
- 2.) Bunn warrants the compressor on refrigeration equipment to be commercially free from defects in material and workmanship for two years from the date of installation.
- 3.) Bunn warrants that the grinding burrs on coffee grinding equipment will grind coffee to meet original factory screen sieve analysis for three years from date of installation or for 30,000 pounds of coffee, whichever comes first.

This warranty does not apply to any equipment, component or part that was not manufactured by Bunn or that, in Bunn's judgement, has been affected by misuse, neglect, alteration, improper installation or operation, improper maintenance or repair, damage or casualty.

THE FOREGOING WARRANTY IS EXCLUSIVE AND IS IN LIEU OF ANY OTHER WARRANTY, WRITTEN OR ORAL, EXPRESS OR IMPLIED, INCLUDING, BUT NOT LIMITED TO, ANY IMPLIED WARRANTY OF EITHER MERCHANTABILITY OR FITNESS FOR A PARTICULAR PURPOSE. The agents, dealers or employees of Bunn are not authorized to make modifications to this warranty or to make additional warranties that are binding on Bunn. Accordingly, statements by such individuals, whether oral or written, do not constitute warranties and should not be relied upon.

The Buyer shall give Bunn prompt notice of any claim to be made under this warranty by telephone at (217) 529-6601 or by writing to Post Office Box 3227, Springfield, Illinois, 62708-3227. If requested by Bunn, the Buyer shall ship the defective equipment prepaid to an authorized Bunn service location. If Bunn determines, in its sole discretion, that the equipment does not conform to the warranty, Bunn shall repair the equipment with no charge for parts during the warranty period and no charge for labor by a Bunn Authorized Service Representative during the warranty period. If Bunn determines that repair is not feasible, Bunn shall, at its sole option, replace the equipment or refund the purchase price for the equipment.

THE BUYER'S REMEDY AGAINST BUNN FOR THE BREACH OF ANY OBLIGATION ARISING OUT OF THE SALE OF THIS EQUIPMENT, WHETHER DERIVED FROM WARRANTY OR OTHERWISE, SHALL BE LIMITED, AS SPECIFIED HEREIN, TO REPAIR OR, AT BUNN'S SOLE OPTION, REPLACEMENT OR REFUND.

In no event shall Bunn be liable for any other damage or loss, including, but not limited to, lost profits, lost sales, loss of use of equipment, claims of Buyer's customers, cost of capital, cost of down time, cost of substitute equipment, facilities or services, or any other special, incidental or consequential damages.

USER NOTICES

Carefully read and follow all notices on the grinder and in this manual. They were written for your protection. All notices on the grinder are to be kept in good condition. Replace any unreadable or damaged labels.

⚠ CAUTION
PERSONAL INJURY HAZARD.
 KEEP FINGERS AND FOREIGN OBJECTS OUT OF HOPPER OR CHUTE OPENING.

#05876.0000

NOTICE
 For connection to Bunn-O-Matic Coffee Brewer Models: Dual, OT, Single, & System III only. (24 volt N.E.C. Class 2 circuit only.)

#24237.0000

⚠ WARNING

- ◆ Use only on a properly protected circuit capable of the rated load.
- ◆ Electrically ground the chassis.
- ◆ Follow national/local electrical codes.
- ◆ Do not use near combustibles.

An extension cord, when used, must be shorter than 20 feet if 16-gage 3-conductor wire, or shorter than 10 feet if 18-gage 3-conductor wire.

FAILURE TO COMPLY RISKS EQUIPMENT DAMAGE, FIRE, OR SHOCK HAZARD

READ THE ENTIRE OPERATING MANUAL INCLUDING THE LIMIT OF WARRANTY AND LIABILITY BEFORE BUYING OR USING THIS PRODUCT

20545-0000 7/90 © 1990 Bunn-O-Matic Corporation

#20545.0000



DISPENSE TIME (Seconds)

Increase ▾ **DISPLAY** ▾ Decrease

+ **-**

Readout will be displayed for 5 minutes.
 Timer can only be adjusted while readout is displayed.

WARNING
HAZARDOUS VOLTAGE

UNPLUG GRINDER BEFORE REMOVING!

#05942.0000
DG-2 ONLY

ELECTRICAL REQUIREMENTS

This grinder has an attached cordset and requires 2-wire, grounded service rated 120 volts ac, 15 amp, single phase, 60 Hz.

OPERATING CONTROLS

Off/On/Start Switch

OFF - (upper position) Switching to this position stops all operation of the grinder.

ON - (middle position) The switch will return to this position after a grind cycle has begun and will remain in this position after grinding has ceased.

START - (lower, momentary position) Pressing the switch to this position and releasing initiates a grind cycle.

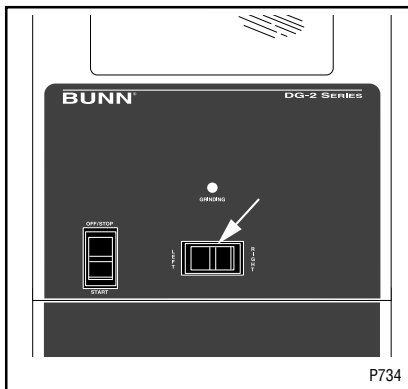

Hopper Selector Switch

LEFT - Switching to this position allows beans to be ground from the left hopper.

RIGHT - Switching to this position allows beans to be ground from the right hopper.

Dispense Timer - DG-2

The dispense timer controls the amount of beans that will be ground in a cycle. The timer can be adjusted to dispense a different amount from each hopper. The scale is from 0.1 to 60.0 seconds. Refer to the Adjustments section for timer setting chart. See page 7.

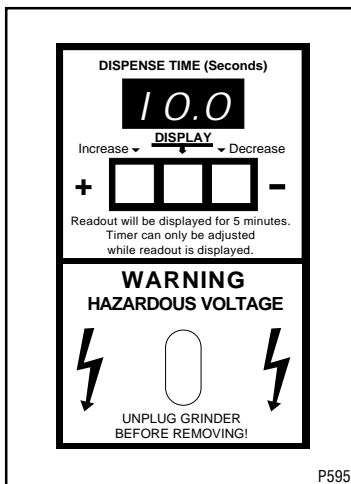

+/Increase - (left momentary push-button)

Pressing this button will increase the dispense interval on the timer while the readout is displayed. The interval will change slowly for the first second's indication, then speed-up for the next fifteen second's indication, and increase very fast after that until it reaches the limit on the scale.

DISPLAY - (center momentary push-button)

Pressing this button will display the current timer readout. The timer can only be adjusted while the readout is displayed. The indication on the display will last for five minutes.

-/Decrease - (right momentary push-button)

Pressing this button will decrease the dispense interval on the timer while the readout is displayed. The interval will change slowly for the first second's indication, then speed-up for the next fifteen second's indication, and increase very fast after that until it reaches the limit on the scale.

DG-2 INITIAL SET-UP

1. **WARNING** - Unplug grinder before removal of any panel.
2. Read NOTICE attached to upper front inspection panel.
3. Remove upper front inspection panel located below control switches and the rear panel.
4. Remove shipping bracket, materials and discard.
5. Reinstall upper front inspection panel and rear panel.
6. Open the top lid(s). Clear all foreign objects and shipping material from the hopper compartments and the entrance to the grind chambers.
7. Remove the lower front inspection panel.
8. Plug-in the grinder.
9. Select either the left or right hopper with the selector switch. Do not press the start switch.
10. The dispense timer panel readout will indicate the present timer setting in seconds and will remain displayed for five minutes.
11. Increase or decrease the timer setting to obtain the desired amount of coffee for the hopper selected by pressing the appropriate button (+ or -).
12. Repeat steps 9 thru 11 for the other hopper. The display will go out on its own. Reinstall lower front inspection panel.
13. Fill the hopper compartments with whole bean coffee. (Capacity 6 pounds each). The grinder is now ready for use.

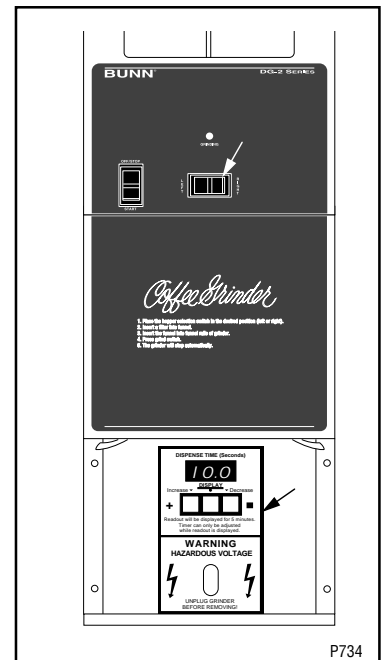

P734

WDG-2 INITIAL SET-UP

1. **WARNING** - Unplug grinder before removal of any panel.
2. Read NOTICE attached to the upper front inspection panel.
3. Remove upper front inspection panel located below control switches and the rear panel.
4. Remove shipping bracket, materials and discard.
5. Reinstall upper front inspection panel and rear panel.
6. Open the top lid(s). Clear all foreign objects and shipping material from the hopper compartments and the entrance to the grind chambers.
7. Remove the four screws securing the lower front inspection panel and carefully pull out far enough to view and operate the digital control display assembly.
8. Plug-in the grinder.
9. Select either the left or right hopper with the selector switch. Do not press the start switch.
10. The digital control display assembly screen displays selected weight when idle. When grinding - display resets to 0.00 and shows increasing weight. Display shows final weight for ten seconds and returns to selected weight.
11. Use (+) or (-) buttons and left or right hopper selector switch to set selected weights, .50 oz minimum - 16 oz maximum.

NOTE: Refer to function list on page 8 for recalibration of weigh control assembly if necessary.

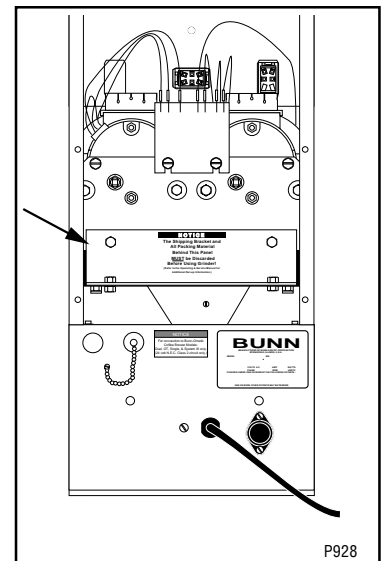

P928

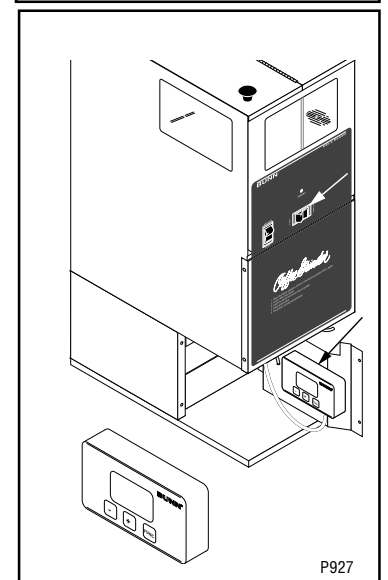

P927

SPECIAL SET-UP FOR FLAVORED COFFEE BEANS

1. **WARNING** - Unplug grinder before removal of any panel.
2. Select the hopper to be used for flavored coffee beans.
3. Remove upper front inspection panel located below control switches.
4. Locate dechaffer blade lever for hopper(s) selected in step #2.
5. Rotate lever clockwise approximately 90°.
6. Remove clip(s) from bag inside of grinder housing and clip to the right of the lever. This will hold the dechaffer open.
7. Reinstall upper front inspection panel.

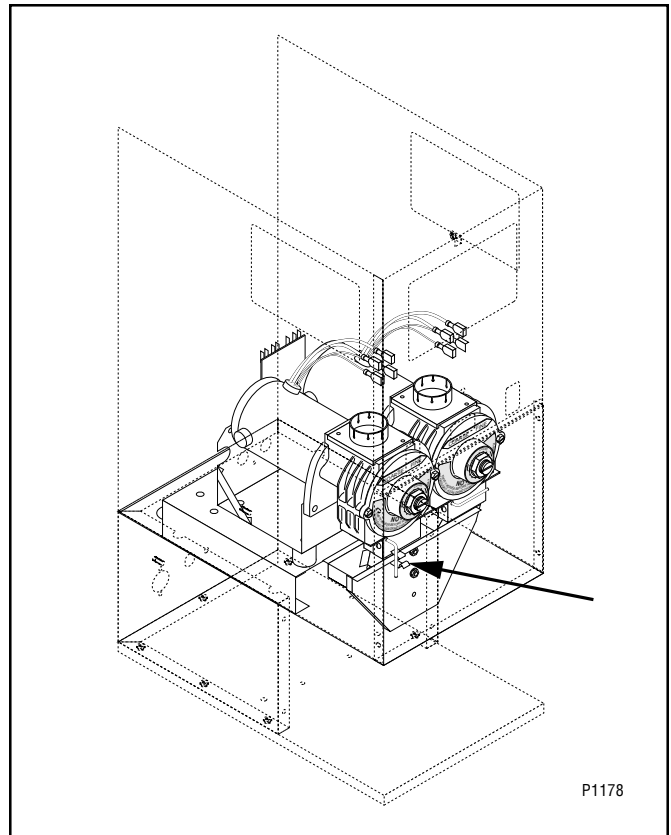

CLEANING EXTERIOR SURFACES

The use of a damp cloth rinsed in any mild, nonabrasive, liquid detergent is recommended for cleaning all surfaces on Bunn-O-Matic equipment. Care should be taken not to scratch the hopper or windows with any abrasive material. Regular cleaning will keep your grinder looking new for years.

GRIND CHAMBER

1. **WARNING** - Unplug grinder before removal of any panel or grind chamber housing parts.
2. Empty all beans from both hoppers.
3. Remove upper front inspection panel located below control switches.
4. Remove the two nuts holding dispense chute cover. Carefully wipe inside surface of dispense chute and cover with a dry clean cloth.
5. Select a grind chamber to clean first. Each grind chamber should be disassembled, cleaned and reassembled before cleaning the opposite side.
6. Remove the two screws holding front cover to burr housing. Carefully remove burr housing front cover. Clean the inside surface with a dry stiff nonmetallic bristle brush and wipe with a dry clean cloth.
7. Carefully remove rotor button, rotor, brass bushing and steel washer from grinder. Clean all parts with a dry stiff nonmetallic bristle brush and wipe with a dry clean cloth.
8. Clean the grind chamber with a dry stiff nonmetallic bristle brush and wipe with a dry clean cloth. Use a small screw driver to dislodge coffee packed in the discharge chute at the base of the grind chamber and wipe clean. Use care not to damage dechaffer blade.
9. Reinstall steel washer, brass bushing (flanged end first), rotor, rotor button and front cover to burr housing.
10. Repeat steps 6 through 9 on remaining grind chamber.
11. Reinstall dispense chute cover.
12. Reinstall upper front inspection panel.
13. Refer to adjustments section below to vary the grind dispensed from each grind chamber.

COFFEE GRINDING

1. Select (either left or right hopper) with selector switch and visually inspect the desired hopper for an ample supply of whole bean coffee.
2. Place a paper filter into the brew funnel. The filter must not be folded-over or tilted to one side.
3. Insert the funnel into the funnel rails and push until it stops.
4. Momentarily press off/on/start switch to the "START" lower position and release. The grinding action will stop automatically after the preset amount of ground coffee is dispensed into the funnel.
5. Remove the funnel from the grinder and level the bed of grounds by gently shaking.
6. The loaded funnel is now ready for use in any commercial drip coffee brewer according to the manufacturer's instructions.

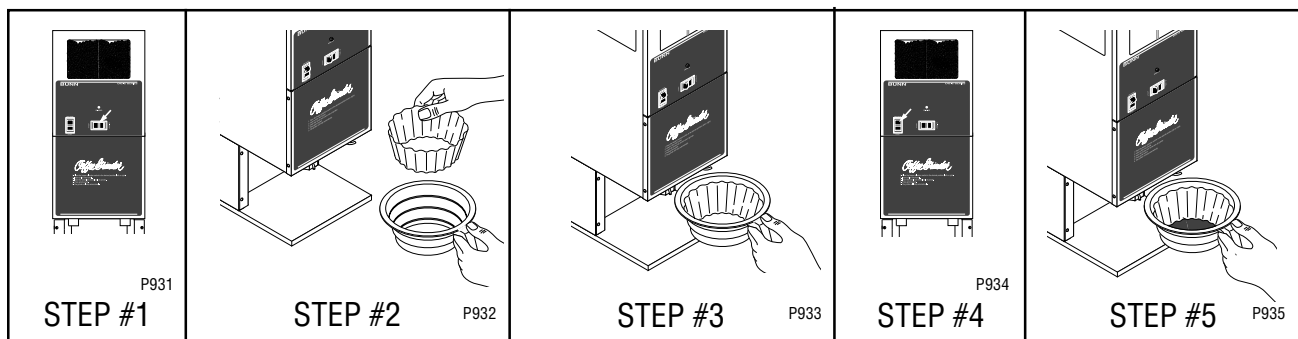

ADJUSTMENTS

The grind can be set from fine to very coarse. The grind may be adjusted for use in most commercial coffee brewers. The following procedures should be used to make adjustments.

NOTE - On DG-2 grinders a change in the burr adjustment will also change the amount dispensed. Any adjustment to the burrs should be followed by an adjustment of the timer,

Burr Adjustment

1. Unplug the grinder and empty all beans from the hopper(s).
2. Plug-in the grinder, place funnel with filter into the funnel rails. Momentarily press the off/on/start switch to the "START" (lower) position (with desired hopper selected) and release, run a few grind cycles until all of the coffee in the grind chamber is dispensed.
3. Remove the upper front inspection panel.
4. Loosen the burr adjustment screw from its locked position.
5. Hand loosen the adjustment locking nut around the screw approximately one turn.
6. Make sure funnel with filter is still in place in the funnel rails. Press the off/on/start switch to the "START" (lower) position and release, slowly turn the adjusting screw in a clockwise direction until a metallic whine is heard due to the rubbing of the grinding burrs. (It may be necessary to start more than one grind cycle to obtain this sound.)
7. Make a mark with a pen on the decal to note the position of the arrow on the grind adjustment screw.
8. The following settings approximately correspond to the CBC recognized grinds. All are referenced from the arrow position marked in step #7.
FINE GRIND: Rotate the adjusting screw 7 hash marks in a counterclockwise direction.
DRIP GRIND: Rotate the adjusting screw 8 hash marks in a counterclockwise direction.
REGULAR (COARSE) GRIND: Rotate the adjusting screw 12 hash marks in a counterclockwise direction.
NOTE: Exact adjustment will vary according to bean roast or added flavoring.
9. Hold the adjusting screw in its set position with a screwdriver while tightening the lock nut to a snug position by hand. The lock nut should now be tight against the burr housing front cover.
10. Repeat steps 1 thru 9 for remaining hopper if desired.
11. Reinstall upper front inspection panel.

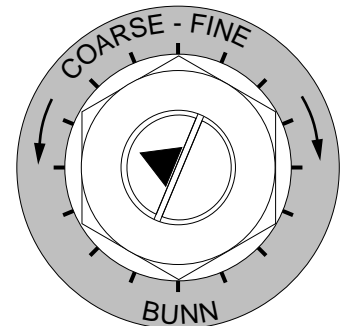

P581

Timer Adjustment - DG-2

1. Unplug the grinder and remove the lower front inspection panel.
2. Determine the grind setting. (The factory setting is **drip**, to determine other settings, refer to the previous section.)
3. Use the instructions below to find the approximate timer setting for the grind and amount of coffee desired.
4. Plug-in grinder and select (left or right) desired hopper. Momentarily press the "DISPLAY" (center) button. The display will indicate the current timer setting and will allow adjustment. Press the "+" or "-" buttons as required to obtain the desired grind time. The interval will change slowly for the first second's indication, then speed-up for the next fifteen second's indication, and increase very fast after that until it reaches the limit on the scale. Set the timer for the desired amount of coffee to be ground.
5. Verify the setting by weighing a few samples. Use the chart on page 10 as an approximate guide only.

Coffee Weight/Timer Settings

Approx. 4.0 seconds per ounce, Medium Roast, Drip Grind.
 Approx. 5.5 seconds per ounce, Dark Roast, Drip Grind.
 Time will vary depending on bean density & grind size.
 Check samples by weight.

DIGITAL CONTROL DISPLAY ASSEMBLY FUNCTION LIST - WDG-2

FUNCTION NO.	FUNCTION	RANGE	
		MIN.	MAX.
	Place funnel with filter into rails, press (Func) button to advance to Function One.		
1.	When entering this function, load sensor is tared. To gain access to remaining functions, press (+) or (-) button once to enter password(0). Display will read (0) now press (Func).	0000	9999
2.	Set weight offset, right grinder. Press (+) or (-) to adjust if necessary. Press (Func).	0.00	9.99
3.	Set weight offset, left grinder. Press (+) or (-) to adjust if necessary. Press (Func).	0.00	9.99
4.	Enter calibration mode? If yes, press (+) display will read (1) then press (Func). If no, press (Func).	0 = No	1 = Yes
	NOTE - Pressing (Func) will return to idle display.		
5.	Use present weight as tare for calibration? If yes, press (+). Display will read (1) then press (Func). If no, press (Func).	0 = No	1 = Yes
6.	To calibrate by grinding coffee, press (+) display will then read (1) then press (Func).	1 = Grind	
7.	Enter desired calibration weight using (+) and (-) buttons. Then press start switch on grinder. Display changes to 0.00 and shows increasing weight as coffee is ground. When grinding stops and 7 has reappeared in left corner of the display. Push (Func) to advance to Function 8 <u>before</u> removing funnel.	3.00	16.00
8.	Weigh sample grind and enter actual weight onto the display by pressing (+) or (-) if necessary. To abort and retain old calibration enter 0.00. Press (Func) when complete.	0.00	16.00
10.	Enter new password. To keep same password press (Func), to change password press (+) or (-), press function to enter new password and return to function 0, normal operation.	0000	9999

NOTE: Display shows "----" when taring. Do not disturb while this is shown.

NOTE: WDG2 Models can be converted from weight based settings to timed settings by pressing the (+) and (-) buttons for 10 seconds. Repeating the process will convert back to weight based settings.

TROUBLESHOOTING

A troubleshooting guide is provided to suggest probable causes and remedies for the most likely problems encountered. If the problem remains after exhausting the troubleshooting steps, contact the Bunn-O-Matic Technical Service Department.

- Inspection, testing, and repair of electrical equipment should be performed only by qualified service personnel.
- All electronic components have 120 volt ac and low voltage dc potential on their terminals. Shorting of terminals or the application of external voltages may result in board failure.
- Intermittent operation of electronic circuit boards is unlikely. Board failure will normally be permanent. If an intermittent condition is encountered, the cause will likely be a switch contact or a loose connection at a terminal or crimp.
- Make certain that all electrical connections are tight and isolated.

WARNING

- Exercise extreme caution when servicing electrical equipment.
- Turn power OFF when servicing, except when electrical tests are specified.
- Follow recommended service procedures.
- Replace all protective shields or safety notices.

Problem	Probable Cause	Remedy
Grinder will not start.	1. No power or incorrect voltage	(A) Plug-in the grinder. (B) Check the voltage at the wall outlet with a voltmeter. It must be 120 volts ac.
	2. Off/On/Start switch	(A) Momentarily press the Off/On/Start switch to the "START" (lower) position. (B) Refer to <i>Service - Off/On/Start switch</i> for testing procedures. See page 13.
	3. (A) Timer - DG-2 (B) Weigh Control Board WDG-2	Refer to <i>Service - Timer</i> for testing procedures. See page 16. Refer to <i>Service - Weight Control Board</i> for testing procedures. See page 18.
	4. Motor overload protector	Remove Grinder rear cover. Press the red "Reset" button, one located on rear of each motor. Listen carefully for a "click". This resets the motor protection circuit and indicates that an overload may have been encountered by the motor. (An overload can occur when something other than coffee is inserted into the hopper for grinding.) Refer to <i>Service - Motors</i> for disassembly procedures. See page 14.

TROUBLESHOOTING (cont.)

Problem	Probable Cause	Remedy
Grinder will not start. (cont.)	5. Motors	Refer to <i>Service</i> - Motors for testing procedures. See page 14.
	6. Fuse	Refer to <i>Service</i> - Fuse for testing procedures. See page 20.
Grinder will not shut off.	1. Off/On/Start switch	A) Place the switch in the "OFF" upper position. B) Refer to <i>Service</i> - Off/On/Start Switch for testing procedures. See page 13.
	2. Timer	Refer to <i>Service</i> - Timer for testing procedures. See page 16.
Grinder starts, but will not dispense from either hopper.	1. Hoppers	Begin each grind cycle by visually inspecting the hoppers for ample supplies of whole bean coffee.
	2. Blockage of hoppers	Foreign materials must not block the openings at the bottom of the hoppers..
Timer will not display or displays incorrectly.	1. Timer	(A) Unplug the grinder. Wait a few seconds and plug it in again. (B) Refer to <i>Service</i> - Timer for testing procedures. See page 16.
Incorrect amount of coffee. DG-2	1. Volume adjustment	Refer to the <i>Adjustments</i> section. See page 7.
	2. Motor circuit assembly	Refer to <i>Service</i> - Motor Circuit Assembly replacement procedures. See page 16.
Incorrect coffee grind dispensed.	1. Burr adjustment	Refer to the <i>Adjustments</i> section. See page 7.
Cooling fan not running.	1. Off/On/Start switch	Switch must be in the "ON" (middle) position
	2. Fan	Refer to <i>Service</i> - Fan. See page 20.

TROUBLESHOOTING (cont.)

Problem	Probable Cause	Remedy
LED will not come on when motor is running.	1. No power 2. Faulty LED	Check timer and for loose connections. Refer to <i>Service</i> - LED. See page 21.
Weigh control assembly leaking oil. WDG-2		Replace - See removal and replacement page 23
Incorrect amount of coffee. WDG-2		Check function list on setting the weight to be ground (page 8), if settings are ok replace weigh control assembly. See page 23 for removal and replacement.

WDG-2 DIGITAL DISPLAY CONTROL FAULT CODES

NOTE: If the grinder stops or fails to start, the green L.E.D. should be flashing. The number of flashes corresponds to the fault code. The fault will also show on the digital display.

FAULT	PROBLEM	PROBABLE CAUSE	REMEDY
1	Grinder on for three seconds without a weight increase.	Selected hopper ran out of whole bean coffee. Foreign objects in motor grinding burrs causing motor to shut off.	Fill selected hopper with whole bean coffee. Clear motor grinding burrs of all foreign objects and press the red "RESET" button on rear of motor.
2	Tare error.	Scale cannot find tare due to excess vibration.	Move grinder to solid, vibration free counter.
4	Grinder motor shutting off in middle of grind.	Power or hopper selector switch changed during grind.	Do not change switches during grind.

SERVICE

This section provides procedures for testing and replacing various major components used in this grinder should service become necessary. Refer to *Troubleshooting* for assistance in determining the cause of any problem.

WARNING - Inspection, testing, and repair of electrical equipment should be performed only by qualified service personnel. The grinder should be unplugged when servicing, except when electrical tests are required and the test procedure specifically states to plug-in the grinder.

Component Access

WARNING - Unplug the grinder before the removal of any panel or the replacement of any component.

All components are accessible by the removal of the upper and lower front inspection panels, hopper assembly, and rear panel.

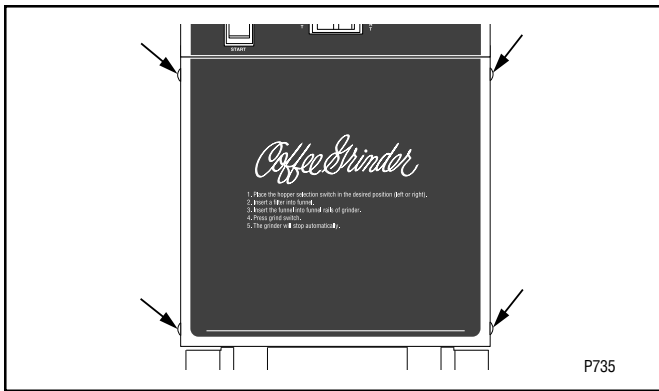

The upper front inspection panel is attached with four 8-32 slotted head screws.

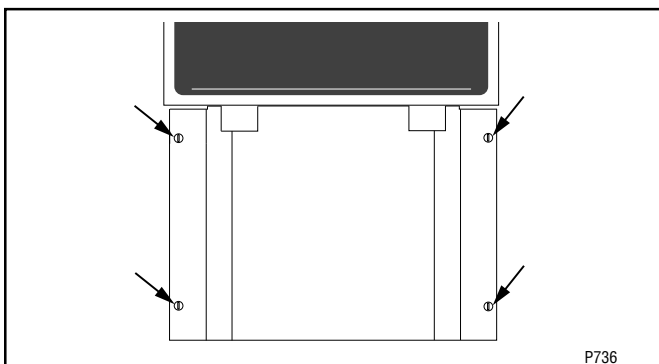

The lower front inspection panel is attached with four 6-32 slotted head screws.

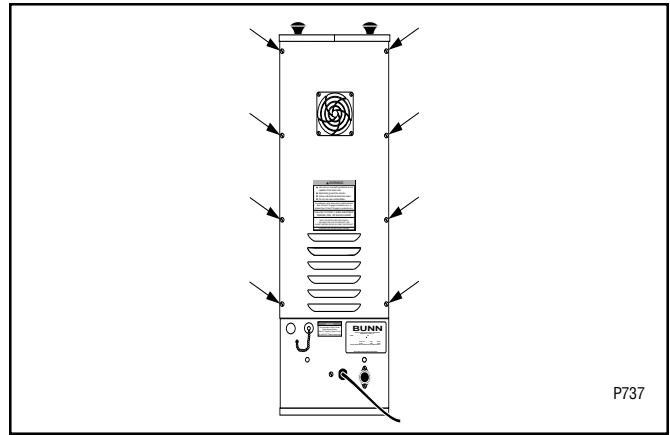

The rear panel is attached with eight 8-32 slotted head screws.

NOTE: Disconnect fan motor leads from main wiring harness.

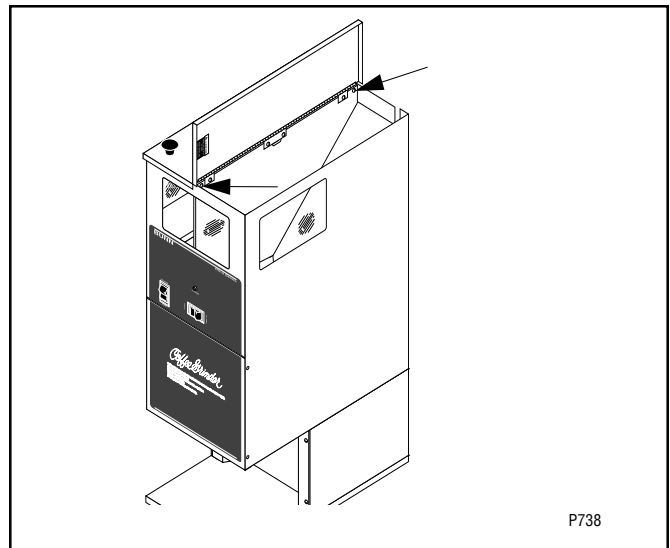

The lid is attached to hopper divider with four 6-32 slotted head screws. Hopper dividers attached to hopper and housing with two 6-32 slotted head screws. Remove lid and hopper divider as an assembly.

CONTENTS

Fan	20
Fuse	20
Hopper Selector Switch	13
LED	21
Motors	14
Motor Circuit Assembly	16
Off/On/Start Switch	13
Timer	16
Weigh Control Board	18
Weigh Control Assembly	21

SERVICE (cont.)

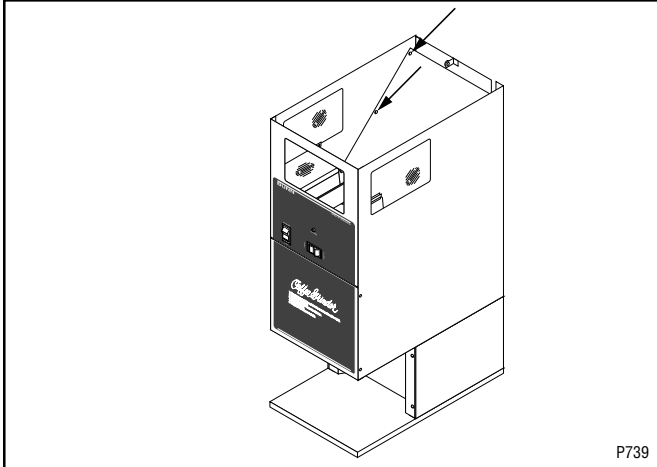

The hopper is attached with ten #8-32 x .25" slotted head locking screws. Remove hopper by lifting up and swing out the rear of the grinder to avoid scratching of windows.

Off/On/Start Switch

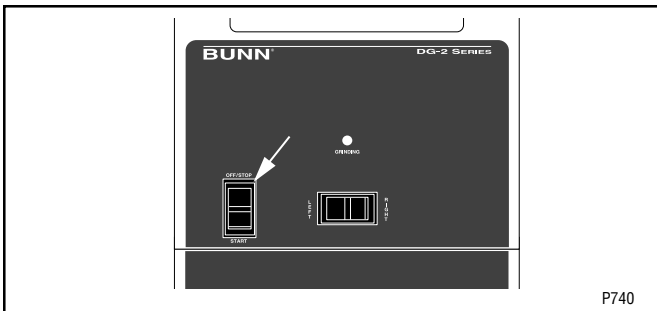

Location:

The Off/On/Start switch is located to the left side on the front of the housing above the upper front inspection panel.

Test Procedure:

1. Unplug the grinder.
2. Remove all wires from the switch terminals.
3. Check for continuity across the terminals on the right side of the switch when it is held in the lower "START" position. Continuity must not be present across these terminals in the center or upper position.

If continuity is present as described, proceed to #4. If continuity is not present as described, replace

the switch.

4. Check for continuity across the terminals on the left side of the switch when it is in the center "ON" position. Continuity must not be present in the upper "OFF" position.

If continuity is present as described, reconnect the wires, the switch is operating properly. If continuity is not present as described, replace the switch.

Removal and Replacement:

1. Remove all wires from the switch terminals.
2. Compress the clips inside the front of the housing and gently push the switch through the opening.
3. Push the new switch into the opening and spread the clips to retain the switch in the housing.
4. Refer to the following illustration when reconnecting the wires.

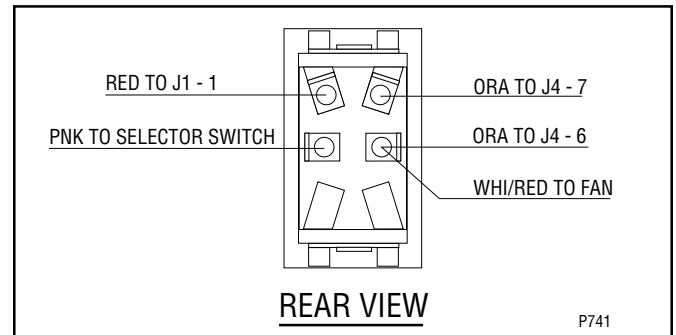

Hopper Selector Switch

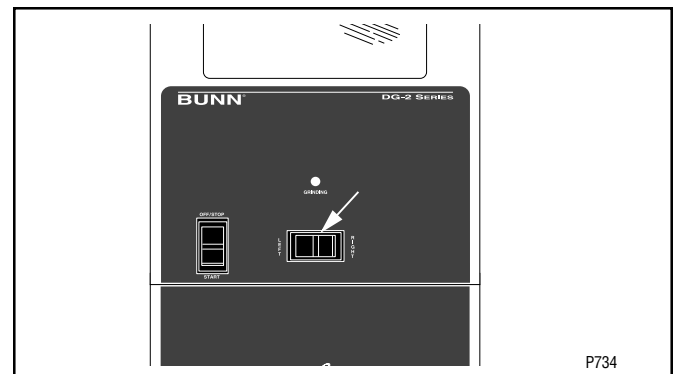

Location:

The Hopper Selector Switch is located in the center on the front of the housing above the upper front inspection panel.

SERVICE (cont.)

Hopper Selector Switch (cont.)

Test Procedure:

1. Disconnect grinder from the power supply.
2. Remove all wires from the switch terminals.
3. Place the selector switch in the left position.
4. Check for continuity across the center and right terminals on the rear of the switch.
5. Continuity must not present across the center and left terminals on the rear of the switch.
6. Check the bottom row, then the top row of terminals.

If continuity is present as described proceed to #7.
If continuity is not present as described, replace the switch.

7. Place the selector switch in the right position.
8. Check for continuity across the center and left terminals on the rear of the switch.
9. Continuity must not be present across the center and right terminals on the rear of the switch.
10. Check the bottom row, then the top row of terminals.

If continuity is present as described, reconnect the wires, the switch is operating properly.
If continuity is not present as described, replace the switch.

Removal and Replacement:

1. Remove all wires from the switch terminals.
2. Compress the clips inside the front of the housing and gently push the switch through the opening.
3. Push the new switch into the opening and spread the clips to retain the switch in the housing.
4. Refer to the following illustration when re-connecting the wires.

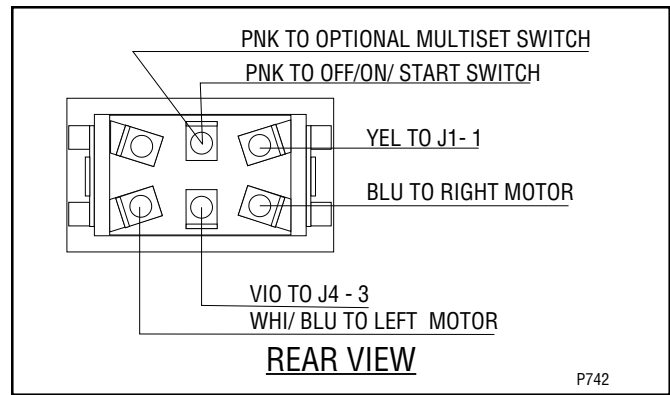

Motors

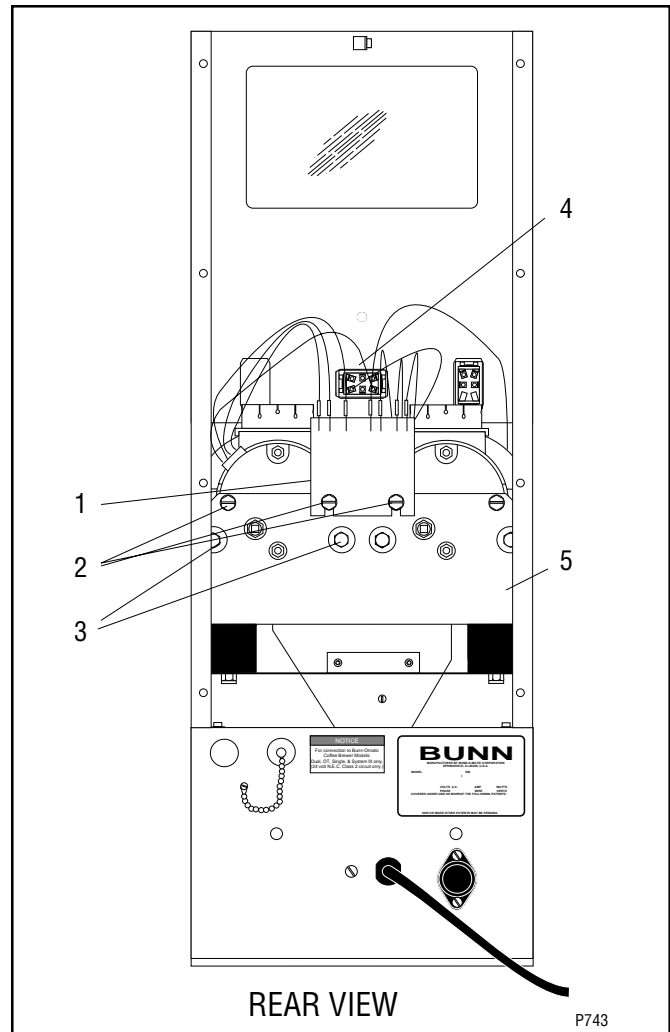

1. Motor Circuit Assembly
2. Motor & Circuit Assembly Mounting Screws
3. Motor Mounting Screws
4. Hopper Selector Switch
5. Motor Mounting Bracket

Location:

The motors are located in the center part of the housing just below the hopper.

SERVICE (cont.)

Motor (cont.)

Test Procedure:

1. Disconnect grinder from the power supply.
2. Remove upper front inspection panel.
3. Remove the two 1/4"-20 screws (A) holding the front cover (B).
4. Remove load disc (C) from burr auger rotor/assembly (D).
5. Remove burr auger rotor/spring assembly (D) from the burr housing (H).
6. Remove rear panel.
7. Disconnect the red, black and blue wires from the left or right motor to the motor circuit assembly (1).
8. (A) Left Motor - Disconnect blue wire on the left motor from the blue wire to the hopper selector switch.
(B) Right Motor- Disconnect the blue wire on the right motor from the white/blue wire to the hopper selector switch.
9. Connect leads of an ohm meter to the blue wires from the left or right motor. Check for continuity.

If continuity is present the motor overload is good. If continuity is not present press the red "RESET" button. Listen carefully for a "click". This resets the motor overload. Recheck for continuity. If continuity is now present the motor overload is reset. If motor overload does not reset replace motor.

10. Set an ohm meter to read at least 10 ohms. Connect leads from ohm meter to the black and red wires from the left or right motor. The ohm reading should be approximately 10 ohms. Rotate the motor shaft approximately 1/8 turn through one full rotation. If ohm readings are consistent motor windings are good. If reading vary more than ± 1 ohm, replace motor.

Removal and Replacement:

1. Disconnect red, black and blue wires from the motor to be removed from the motor circuit assembly (1).
2. Loosen the two #10-32 slotted head screws (2) attaching motor circuit assembly (1) to motor mounting bracket (5).
3. Remove motor circuit assembly (1) with wires from harness and the opposite motor connected.
4. Right Motor - Disconnect blue wire on motor from blue wire on hopper selector switch (4).
Left Motor - Disconnect blue wire on motor from white/blue wire on hopper selector switch (4).
5. Using a 7/16" socket, extension and ratchet remove two 1/4"-20 hex head capscrews and lockwashers (3) attaching front of motor to front of mounting bracket (5).
6. Remove two #10-32 slotted hex head screws (2).
7. Lift motor out of mounting bracket (5) and remove through the rear of grinder with hopper collar and discharge chute assembly attached.
8. Remove four #10-24 slotted hex head screws attaching discharge chute to motor. Remove discharge chute. Set discharge chute and screws aside for reassembly.
9. On new motor assembly with hopper collar install discharge chute assembly using four #10-24 slotted hex head screws.
10. Mount new motor, hopper collar and discharge chute assembly on mounting bracket using two 1/4"-20 hex head capscrews and lockwashers (3) and two #10-32 slotted hex head screws (2) and one external tooth lockwasher.
11. Install motor circuit assembly (1) between head of the two #10-32 slotted hex head screws (2) and external tooth lockwashers. Tighten screws (2).
12. Refer to wiring diagram (pages 24 & 25) and connect wires from motor to motor circuit assembly (1) and hopper selector switch (4).

SERVICE (cont.)

Motor (cont.)

Removal and Replacement - GRIND CHAMBER

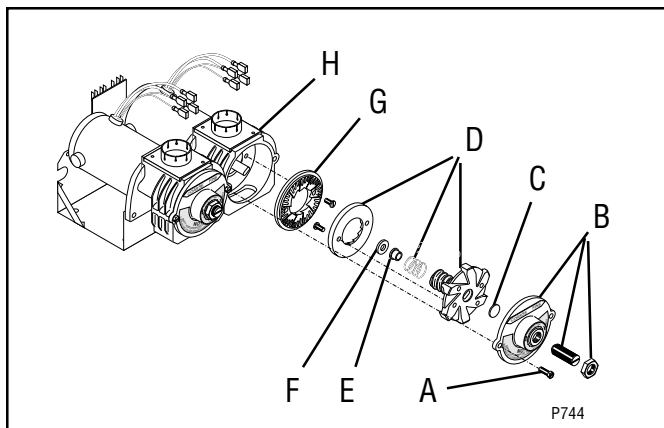

1. Remove the two 1/4"-20 screws (A) holding the front cover (B) to the burr housing (H). Carefully remove the burr housing front cover with adjusting screw and nut. Inspect adjusting screw to see if worn.
Replace if excessively worn or damaged.
2. Remove load disc (C) from burr auger rotor/spring assembly (D). Inspect disc to see if worn.
Replace if excessively worn or damaged.
3. Carefully remove burr auger rotor/spring assembly (D) from burr housing (H). Inspect burr for wear.
Replace if excessively worn or damaged.
4. Remove bushing (E) and washer (F) from motor shaft.
5. Remove the two 1/4"-20 screws attaching stationary burr (G) to burr housing (H). Remove and inspect burr for wear.
Replace if excessively worn or damaged.
6. Inspect the grind chamber and remove any foreign materials. The burrs will not properly seat in the chamber if any material or coffee particles remain.
7. Reinstall the stationary burr (G), washer (F), bushing (E), burr auger rotor/spring assembly (D), load disc (C) and burr housing front cover (B) with adjusting screw and nut to the burr housing (H).
8. Refer to *Adjustments* section (page 7) to vary the grind dispensed.

Motor Circuit Assembly

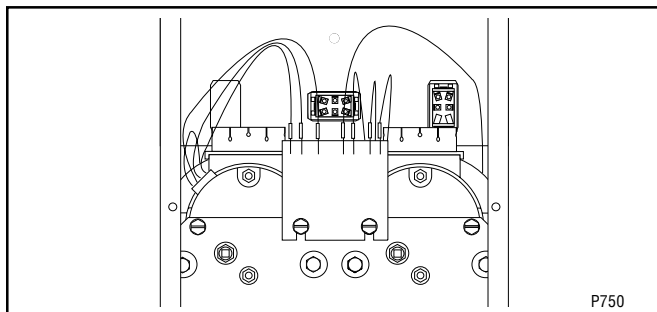

Location:

The motor circuit assembly is located on the rear of motor mounting bracket.

Test Procedure:

1. The motor circuit assembly is a line filter for motor electrical noise.
2. If the timer settings are erratic or change replace the motor circuit assembly board.

Removal and Replacement:

1. Remove all wires.
2. Loosen the two #10-32 slotted hex head screw and lift motor circuit assembly off.
3. Install new motor circuit assembly between head of screws and external tooth lockwashers. Tighten screws.
4. Refer to *Wiring Diagram* (pages 24 & 25) and reinstall wires.

Timer - DG-2

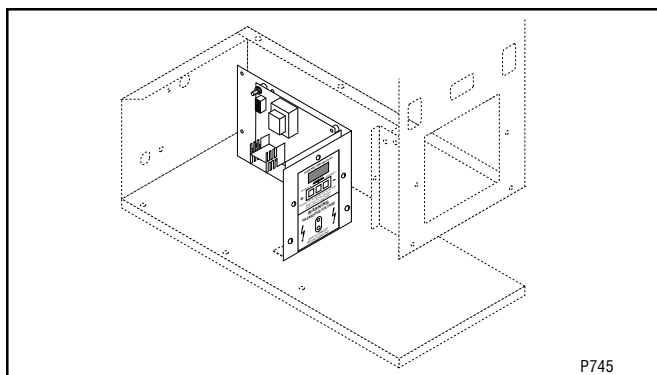

Location:

The timer is located on the grinder base, behind the lower front inspection panel.

SERVICE (cont.)

Timer - DG-2 (cont.)

Test Procedure:

1. Disconnect grinder from the power source.
2. Slide timer with wires connected from housing.
3. Place the hopper selector switch in the left position.
4. Disconnect eight pin plug J4 from timer board.
5. Check the voltage between J4-1 and J4-2 with a voltmeter. Connect the grinder to the power source. The indication must be 120 volts AC.
6. Disconnect grinder from the power source.

If voltage is present as described, proceed to #7.

If voltage is not present as described, refer to the wiring diagram and check grinder wiring harness.

7. Check the voltage between J4-2 and J4-6 with a voltmeter when the "OFF/ON/START" switch is in the "ON" position. Connect the grinder to the power source. The indication must be 120 volts AC.
8. Disconnect grinder from the power source.

If voltage is present as described, proceed to #9.

If voltage is not present as described, refer to the wiring diagram and check the grinder wiring harness.

9. Grinders prior to S/N DG00002660:
Check the voltage between J4-3 (+) and J4-5 (-) with a voltmeter set to read DC voltage when the "OFF/ON/START" switch is in the "START" position. The indication must be 110 volts DC minimum.

Grinders S/N DG00002660 - UP

Check the voltage between J4-3 and J4-5 with a voltmeter when the "OFF/ON/START" is in the "START" position. The indication must be 120 volts AC.

10. Disconnect grinder from the power source.

If voltage is present as described, proceed to #11.
If voltage is not present as described, replace timer and motor circuit board with part number 25725.1000. On grinders prior to S/N DG00002660 also order main wiring harness 25762.0001.

11. Reconnect the wires.
12. Place the hopper selector in the right position.
13. Repeat steps #4 thru 10.

Grinders with One or Two Brewer Optional Interface

1. Set the brewer selector switch on one third batch with grinder "OFF/ON/START" switch in the "ON" position.
2. Select the two third's batch, if the readout is not different then adjust the settings and return selector switch to one third batch. The readout should now be different.
3. Select full batch, if the readout is not different then adjust the settings and return selector switch to two third's batch. The readout should be different.
4. Repeat steps 1 thru 3 for the opposite side.

NOTE: Each brew selection has its own readout. If readouts do not differ with each brew selection after adjusting settings, check interface cable. If interface cable is ok replace timer and motor circuit board with part number 25725.1000. On grinders prior to S/N DG00002660 also order main wiring harness part number 25762.0001.

Removal and Replacement:

1. Separate the grinder wiring harness connectors from the timer circuit board.
2. Refer to the illustration on next page when reattaching the connectors.
3. Refer to the *Adjustments* (page 7) section to reset the volume dispensed.

SERVICE (cont.)

Timer - DG-2 (cont.)

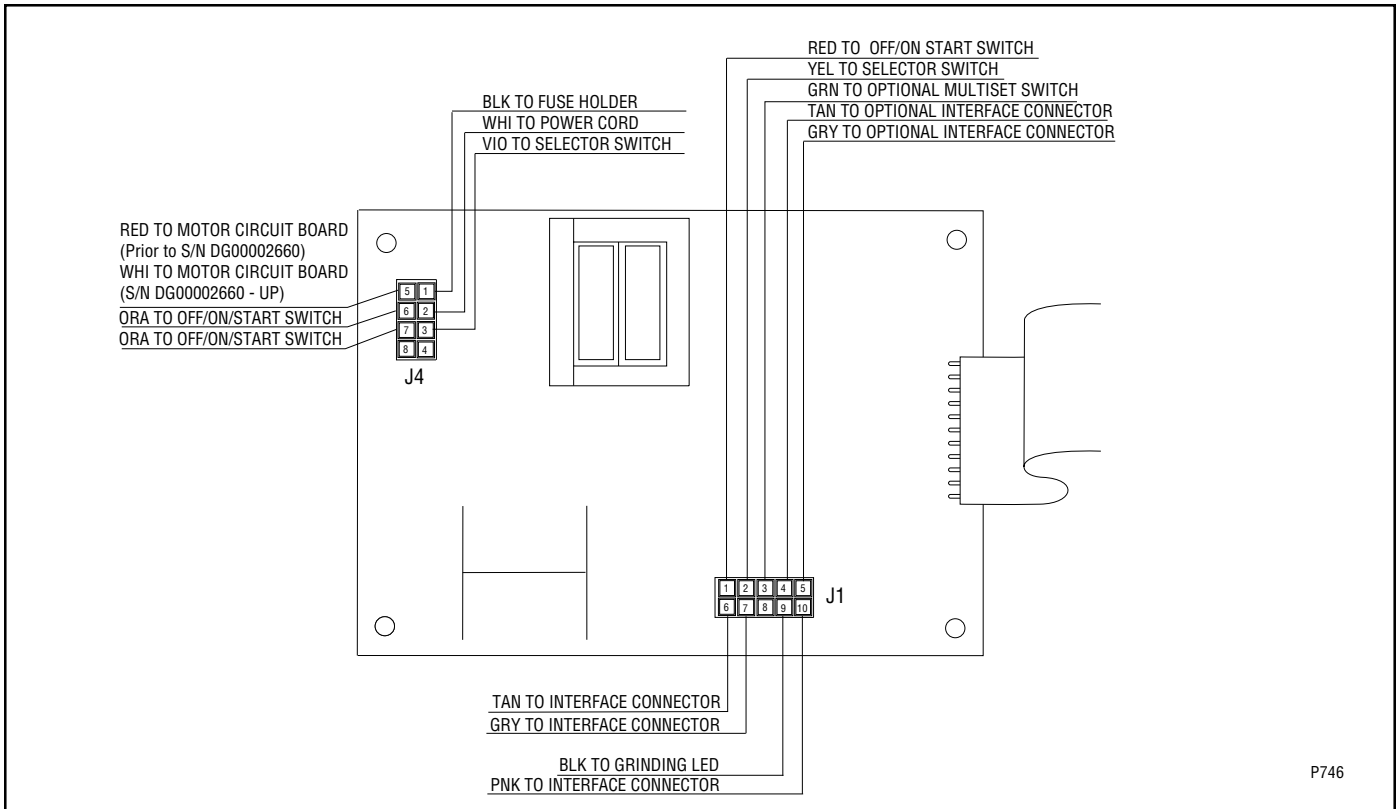

Weigh Control Board - WDG-2

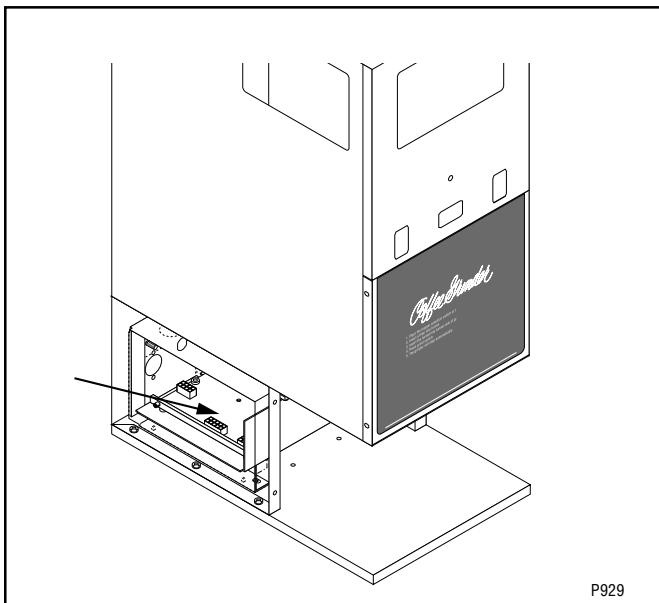

Location

The weigh control board is located on the grinder base behind the lower front inspection panel.

Test Procedure:

1. Disconnect grinder from the power source.
2. Slide the weigh control board with wires connected from housing.
3. Place the hopper selector switch in the left position.
4. Disconnect eight pin plug J4 from weigh control board.
5. Check the voltage between J4-1 and J4-2 with a voltmeter. Connect the grinder to the power source. The indication must be 120 volts AC.
6. Disconnect grinder from the power source.

If voltage is present as described, proceed to #7.
If voltage is not present as described, refer to the wiring diagram and check grinder wiring harness.

7. Check the voltage between the J4-2 and J4-6 with a voltmeter when the "OFF/ON/START" switch is in the "ON" position. Connect grinder to the power source. The indication must be 120 volts AC.

SERVICE (cont.)

Weigh Control Board - WDG-2 (cont.)

8. Disconnect grinder from the power source.

If voltage is present as described, proceed to #9.
If voltage is not present as described, refer to the wiring diagram and check the grinder wiring harness.

9. Check the voltage between J4-3 and J4-5 with a voltmeter when the "OFF/ON/START" is in the "START" position. Connect grinder to the power source. The indication must be 120 volts AC.
10. Disconnect grinder from the power source.

If voltage is present as described, proceed to #11.
If voltage is not present as described, replace weigh control board.

11. Reconnect the wires.
12. Place the hopper selector in the right position.
13. Repeat steps #4 thru 10.

Grinders with One or Two Brewer Optional Interface

1. Set the brewer selector switch on one third batch with grinder "OFF/ON/START" switch in the "ON" position.
 2. Select the two third's batch, if the readout is not different then adjust the settings and return selector switch to one third batch. The readout should now be different.
 3. Select full batch, if the readout is not different then adjust the settings and return selector switch to two third's batch. The readout should be different.
 4. Repeat steps 1 thru 3 for the opposite side.
- NOTE:** Each brew selection has its own readout. If readouts do not differ with each brew selection after adjusting settings, check interface cable. If interface cable is ok replace weigh control board.

Removal and Replacement:

1. Separate the grinder wiring harness connectors from the weigh control board.
2. Refer to the illustration below when re- attaching the connectors.
3. Refer to the *Adjustments* (page 7) section to re-set the volume dispensed.

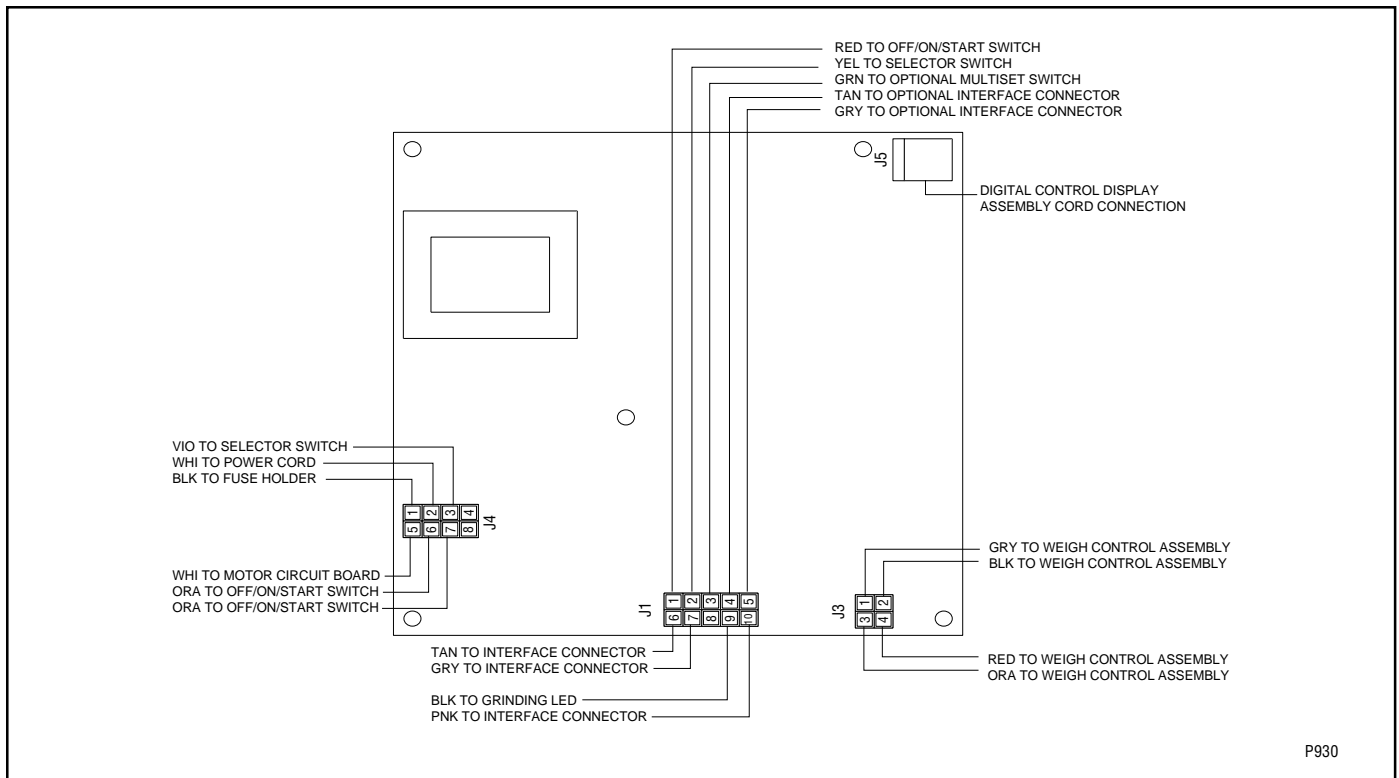

P930

SERVICE (cont.)

Fan

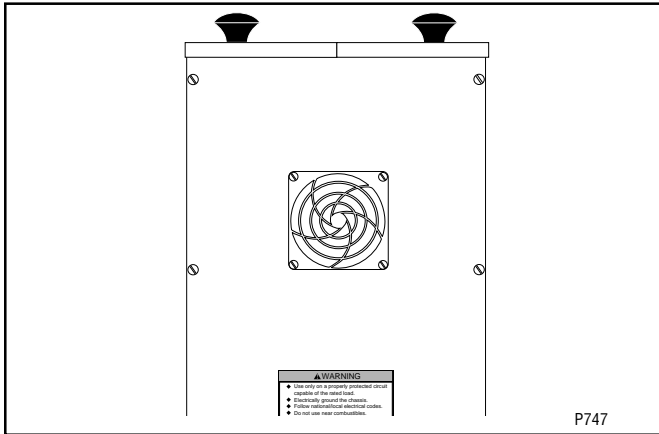

Location:

The fan is mounted on upper part of the rear inspection panel.

Test Procedure:

1. Unplug the grinder.
2. To gain access remove the rear panel with fan attached.
3. Disconnect fan motor leads from the main harness.
4. Check voltage across the WHT/RED and WHT leads to the main harness with a voltmeter. Plug-in the grinder. With the "OFF/ON/START" switch in the center "ON" position the indication must be 120 volts AC.
5. Unplug the grinder.

If voltage is present as described, replace the fan.
If voltage is not present as described, refer to wiring diagrams and check the wiring harness.

Removal and Replacement:

1. Remove rear panel with fan attached.
2. Disconnect fan motor leads from main harness
3. Remove four #6-32 flat head screws and lock-nuts attaching fan and fan guard to rear inspection panel. Discard fan and set guard, screws and locknuts aside for reinstallation.
4. Reinstall fan guard and new fan to the rear panel making sure the air flow direction is away from rear panel.
5. Connect leads from fan to the main wiring harness.
6. Reinstall rear panel.

Fuse

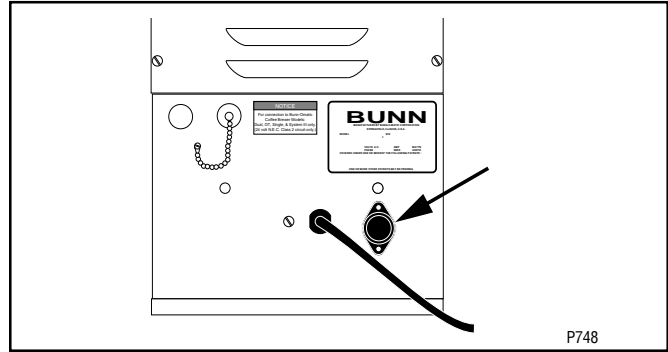

Location:

The fuse is located in the fuse holder on the rear of grinder near the bottom next to the power cord.

Test Procedure:

1. Unplug the grinder.
2. Remove cap and fuse from fuse holder.
3. Remove fuse from the cap.
4. Check for continuity through the fuse.

If continuity is present as described, reinstall the fuse, the fuse is operating properly.

If continuity is not present as described, replace the fuse.

Removal and Replacement:

1. Remove cap from fuse holder.
2. Remove fuse from fuse holder, inspect, if blown discard.
3. Install a new SC 10 x .312" fuse in fuse holder.
4. Reinstall fuse holder cap.

SERVICE (cont.)

L.E.D

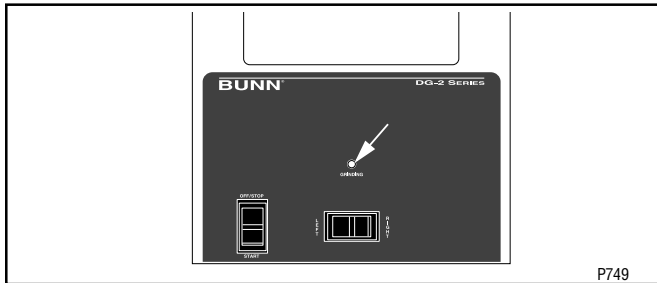

Location:

The L.E.D is located on the front of the grinder just above hopper selector switch.

Test Procedure:

1. Unplug the grinder.
2. Remove the wire nuts from both sets of wires.
3. With a voltmeter set to read DC volts. Attach the positive (+) lead to the black and pink wires and the negative (-) lead to the gray wires.
4. Connect grinder to the power supply.
5. Initiate a grind cycle. Voltage should be approximately 2 volts DC.

If the voltage is present as described the L.E.D. is operating properly.

If the voltage is not present as described proceed to #6.

6. After initiating a grind cycle in step #5 the voltage was approximately 5 volts DC. Replace the L.E.D. If the voltage is approximately 0 volts refer to wiring diagrams and check the wiring harness.

Removal and Replacement:

1. Remove upper front inspection panel.
2. Disconnect PNK and GRY wires from L.E.D.
3. Using a 5/16" open end wrench remove nut on back of front housing securing L.E.D. Remove L.E.D and discard.
4. Install new L.E.D through front of grinder housing and secure with nut.
5. Connect PNK and GRY wires from L.E.D. Refer to wiring diagram on pages 24 & 25.

Weigh Control Assembly - WDG-2

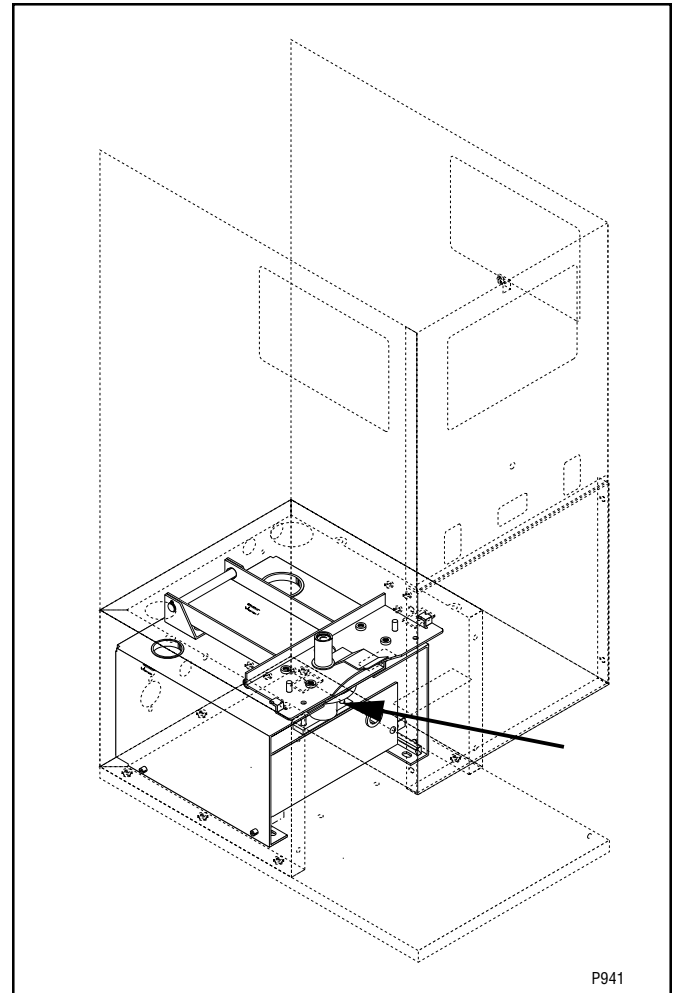

Location:

The weigh control assembly is located behind the lower front inspection panel just under and behind the funnel rails.

SERVICE (cont.)

Weigh Control Assembly - WDG-2 (cont.)

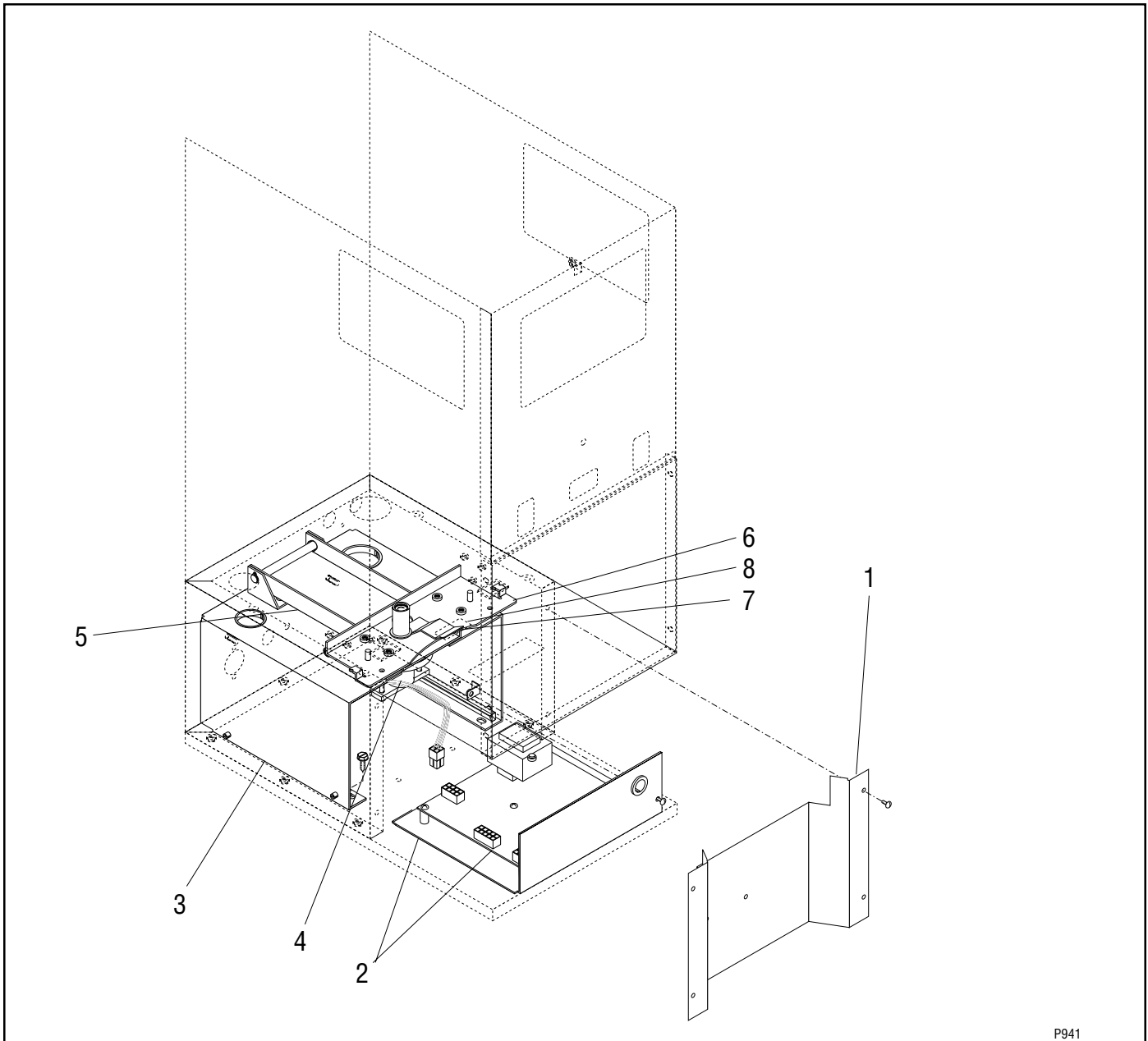

P941

- | | | | |
|----|--|----|-------------------------------|
| 1. | Front Inspection Panel | 5. | Pivot Arm |
| 2. | Weigh Control Board and Mounting Bracket | 6. | Funnel Rails Mounting Bracket |
| 3. | Weigh Control Mounting Bracket | 7. | Funnel Tab |
| 4. | Weigh Control Assembly | 8. | Slot in Housing Assembly |

SERVICE (cont.)

Weigh Control Assembly - WDG-2 (cont.)

Removal and Replacement

1. Disconnect grinder from the power source.
2. Remove the four #6-32 truss head screws securing lower front inspection panel (1). Remove panel with digital control display assembly attached.
3. Remove the one #6-32 truss head screw securing the weigh control board mounting bracket (2) to the weigh assembly mounting bracket (3).
4. Slide weigh control board mounting bracket and control board (2) out of weigh assembly mounting bracket (3) far enough so the connectors on the grinders main wiring harness and the connector on the weight assembly leads can be disconnected.
5. Disconnect connectors.
6. Remove weigh control board mounting bracket and weigh control board (2) from the grinder.
7. Remove the two #10-32 slotted head screws securing weigh control mounting bracket (3) to the base of the grinder and the two #10-32 keps nuts securing the weigh control mounting bracket (3) to the rear of the grinder housing.
8. Slide weigh control mounting bracket (3) from grinder housing far enough to have access to weigh control assembly (4).
9. Holding pivot arm w/overload assembly (5) up remove the four #8-32 pan head screws securing weigh control assembly (4). Remove and discard weigh control assembly (4).
10. Holding pivot arm w/overload assembly (5) up install the new weigh control assembly (4) to the mounting bracket (3) using four #8-32 pan head screws.
11. Slide weigh control assembly mounting bracket (3) on to the two studs on the rear of the grinder housing and secure with two #10-32 keps nuts.

NOTE - Carefully guide all wires while installing the weigh mechanism. The funnel tab (7) on the funnel rails mounting bracket (6) must be in clearance slot (8) in the grinder housing and must move freely up and down.

12. Secure weigh control assembly mounting bracket (3) to grinder base with two #10-32 slotted head screws.
13. Slide the weigh control bracket and weigh control board (2) into the weigh control mounting bracket (3) far enough to reconnect the eight and ten pin connectors from the main wiring harness and the four pin connector from the weigh control assembly. Connect the wiring.
14. Refer to the illustration on page 19 when reattaching the connectors.

NOTE - Inspect for pinched wires.

15. Slide weigh control bracket and weigh control board (2) the rest of the way into the weigh control mounting bracket (3) and secure with one #6-32 truss head screw.
16. Reinstall lower front inspection panel with digital control display assembly attached using four #6-32 truss head screws.
17. Connect the grinder to the power source and follow the function list on page 8 for information on setting the weight to be ground.

WIRING DIAGRAMS

SCHEMATIC WIRING DIAGRAM DG2

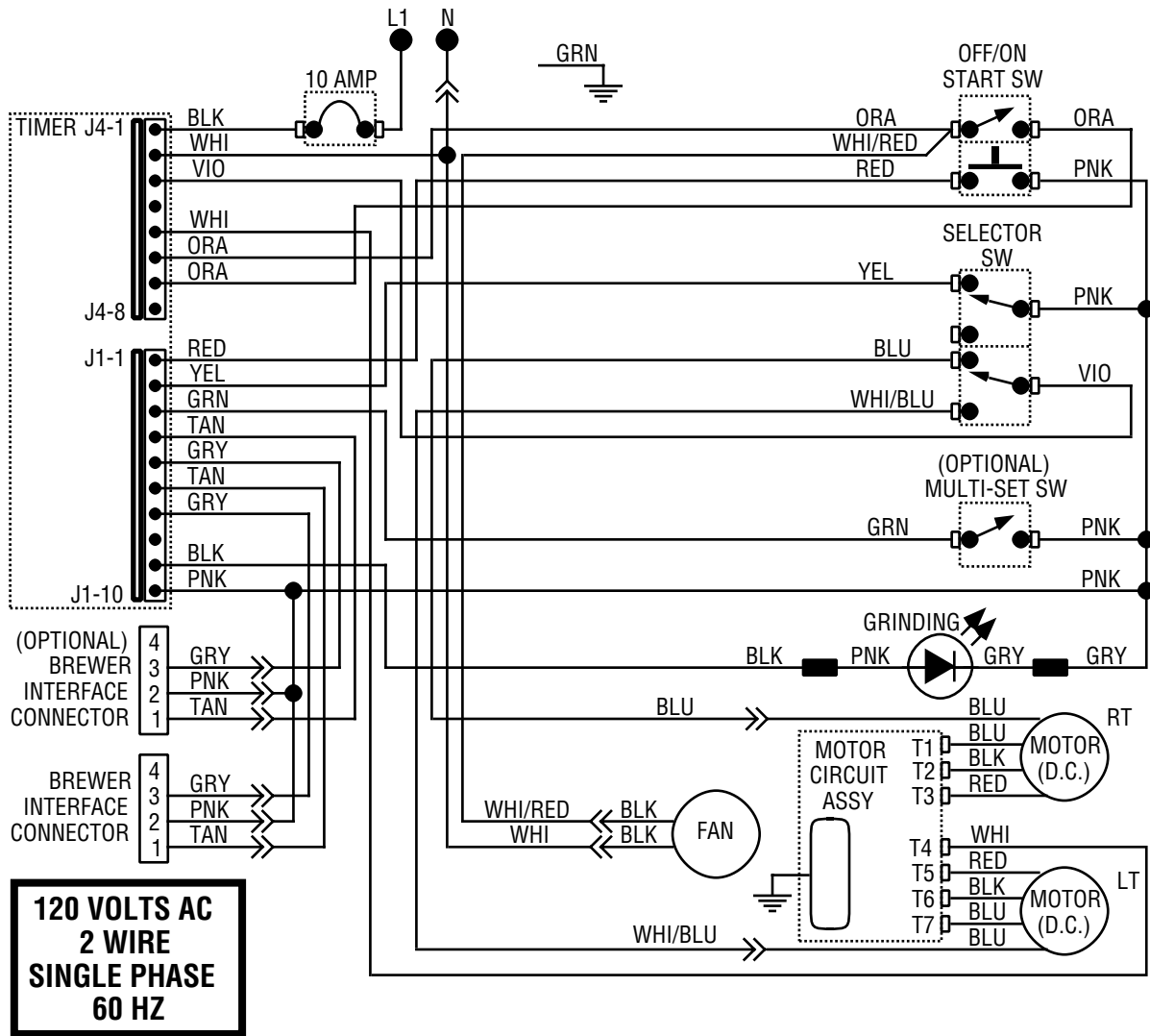

WIRING DIAGRAMS

SCHEMATIC WIRING DIAGRAM WDG2

