

---

# BUNN®

## Digital ThermoFresh® 1.0 & 1.5 Gallon Server with Countdown Timer



## USE & CARE INFORMATION

**CAUTION: CLEAN AND SANITIZE YOUR SERVER BEFORE USING. SEE NOTE #1 of DAILY CLEANING.**

### BUNN-O-MATIC CORPORATION

POST OFFICE BOX 3227  
SPRINGFIELD, ILLINOIS 62708-3227  
PHONE: (217) 529-6601 FAX: (217) 529-6644

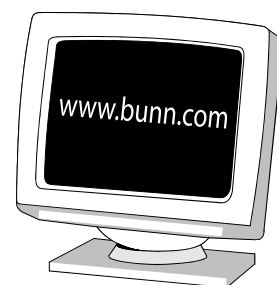

## INTRODUCTION

This server is intended for use with a BUNN® DUAL® TF DBC®, SINGLE® TF DBC® or ICB family brewers. When proper precautions are followed, 1.0 up to 1.5 gallons of coffee may be brewed directly into the server and then transported to a remote serving location. The server must be placed on a sturdy counter or shelf.

**NOTE:** Calibration of the brewer is required prior to the use of the Digital TF Server.

## USER NOTICES

The notices on this server should be kept in good condition. Replace unreadable or damaged labels.



35710.0000



45457.0000



#39043.0000



#39043.0001

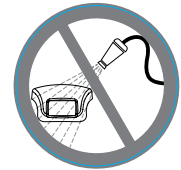

#39043.0002

## DAILY CLEANING

**CAUTION:** CLEAN AND SANITIZE YOUR SERVER **DAILY**

**NOTE:** Bunn-O-Matic recommends the 3 step method for cleaning and sanitizing the server. The 3 step method consists of hot soapy water using an approved detergent, a fresh water rinse, and an aqueous sanitizing solution using an approved **non-chlorine** sanitizer. **Do not submerge server.**

1. Run a complete brew cycle *of just hot water* into the server and let it set for a minute. Empty the server completely by opening the faucet.
2. Remove the sensor assembly, fill server with cleaning solution and thoroughly clean the inside of server.
3. Rinse server thoroughly using fresh water rinse.
4. Fill server with sanitizing solution and let the server set for 5 minutes, then drain through fully open faucet. Thoroughly rinse server after sanitizing.
5. Remove the faucet handle/stem assembly by unscrewing the faucet nut just beneath the faucet handle.
6. Use enclosed cleaning brush to thoroughly clean the faucet body and tube.
7. Disassemble the faucet/stem assembly. Thoroughly wash all faucet parts in a mild detergent and water solution. Rinse the parts in hot water. Sanitize the parts for five minutes, thoroughly rinse, then air dry completely.
8. Use enclosed cleaning brush to thoroughly clean the fill tube of the sensor assembly.

**NOTE:** Never submerge the Digital ThermoFresh® Server Display or sensor assembly in water.

9. Wipe sensor assembly with a clean, damp cloth.
10. Reassemble the faucet and attach it to the dispenser.
11. Wash the entire outside surface of the server and display with a clean damp cloth.

## PERIODIC CLEANING

1. Remove the sensor assembly from the server.
2. Remove the two thumb screws and slide display assembly from the server.
3. Wipe the surface of the display unit, area under the display unit, and sensor assembly with a clean damp cloth.
4. Wash the entire outside surface of the sensor assembly with a mild detergent and water solution and rinse with hot water. **Do not submerge.** **NOTE:** Thoroughly cleaning the sensor assembly fins will prevent inaccurate level readings.
5. Replace the display unit and sensor assembly.

# SERVER WITH STAND

## REPLACEMENT PARTS

- 1. 42554.1002 Display Kit, Countdown (Includes items 2 - 4)
- 2. 42826.1000 Screw, Thumb #6-32 x .25"
- 3. 46247.1000 Batteries, 4 Pack AAA
- 4. 42546.0001 Gasket, Battery Cover
- 5. 42547.0001 Cover, Battery
- 6. 02361.0000 Screw, Pan Head #4-40 x .25"
- 7. 43135.0000 Handle, Faucet
- 8. 35003.0000 Nut, Faucet Spout
- 9. 00601.1000 Faucet Spring (Package of 6)
- 10. 29164.1000 Faucet Stem (Package of 6)
- 11. 00600.1000 Faucet Seat Cup (Package of 6)
- 12. 42567.0000 Faucet Body
- 13. 42543.0000 Guard, Faucet
- 14. 35074.1000 Screw, Pan Head M4 x .7 x .25
- 15. 43231.0000 Washer, M4 x 9MM
- 16. 42584.1000 Plug, Front (Package of 10)
- 17. 42818.1001 Sensor Assy, 1.0 Gal (Includes items 14 & 15)
- 18. 42565.1000 Sensor Assy, 1.5 Gal (Includes items 14 & 15)
- 19. 42563.1002 Cap, Sensor Assy (Package of 5)
- 20. 39043.0000 Decal, Do Not Submerge
- 21. 42562.0000\* Handle, Server
- 22. 42758.0000\* Shoulder Screw
- 23. 42585.1000 Plug, Rear (Package of 10)
- 24. 43246.1000 Cover Assy, Top
- 25. 42761.0000\* Screw, Pan Head M4 x 9
- 26. 35710.0000 Decal, Warning Hot Liquid
- 27. 32591.1000 Tube, Silicone .50" ID x 12.0" LG (cut to length)
- 28. 28526.1000 Tube, Silicone .31" ID x 12.0" LG (cut to length)
- 29. 42912.0000 Foot, Rubber
- 30. 43163.0000 Screw, Pan Head #8 x .75"
- 31. 42295.0001 Elbow, 90°
- 32. 42890.1000 Base Cover
- 33. 35016.0001 Insert, Stand
- 34. 38929.0002 Stand, Server
- 35. 39617.0000 Screw, Pan Hd Plastite #6 x .75"
- 36. 38930.0002 Base Plate, Stand
- 37. 44010.0000 Screw, Pan Head #8 x .50"
- 38. 39443.1003 Pad, Adhesive Back .75" Dia.
- 39. 38931.1002 Kit, Drip Tray (Includes item 31)
- 40. 38932.0000 Cover, Drip Tray
- 41. 45457.0000\* Decal, Do not Submerge
- 42. 39043.0002\* Decal, Do not Spray
- 43. 39043.0001\* Decal, Do not Submerge Server
- 44. 42889.0000 Seal
- 45. 35071.0000 Decal, Black Wrap 1.5 Gal. (Not Illustrated)
- 46. 37974.0000 Decal, Black Wrap 1.0 Gal. (Not Illustrated)
- 47. 35301.0001 Brush, Cleaning (Not Illustrated)

\* Components of item 19

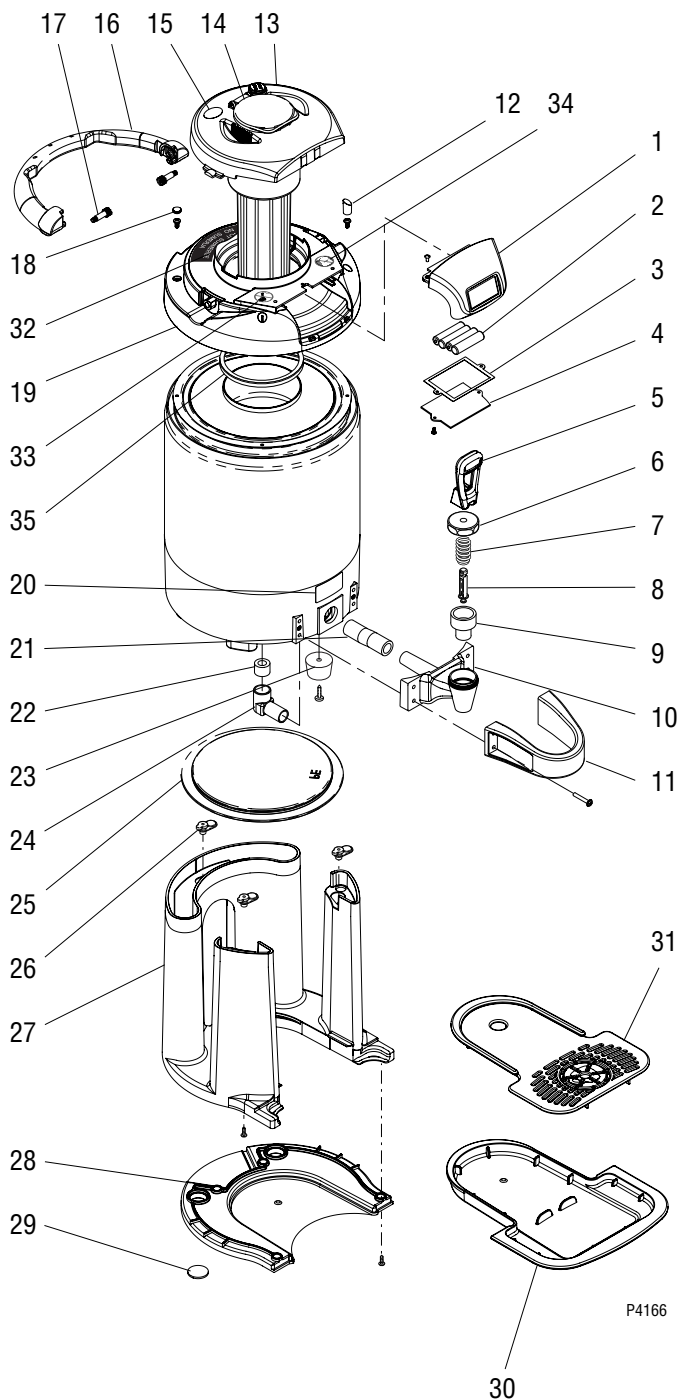

P4166

# SERVER WITHOUT STAND

## REPLACEMENT PARTS

1. 42554.1002 Display Kit, Countdown (Includes items 2 - 4)
  2. 42826.1000 Screw, Thumb #6-32 x .25"
  3. 46247.1000 Batteries, 4 Pack AAA
  4. 42546.0001 Gasket, Battery Cover
  5. 42547.0001 Cover, Battery
  6. 02361.0000 Screw, Pan Head #4-40 x .25"
  7. 43135.0000 Handle, Faucet
  8. 35003.0000 Nut, Faucet Spout
  9. 00601.1000 Faucet Spring (Package of 6)
  10. 29164.1000 Faucet Stem (Package of 6)
  11. 00600.1000 Faucet Seat Cup (Package of 6)
  12. 42567.0000 Faucet Body
  13. 42543.0000 Guard, Faucet
  14. 35074.1000 Screw, Pan Head M4 x .7 x .25
  15. 43231.0000 Washer, M4 x 9MM
  16. 42584.1000 Plug, Front (Package of 10)
  17. 42818.1001 Sensor Assy, 1.0 Gal (Includes items 14 &15)
  18. 42565.1000 Sensor Assy, 1.5 Gal (Includes items 14 &15)
  19. 42563.1002 Cap
  20. 39043.0000 Decal, Do Not Submerge
  21. 42562.0000\* Handle, Server
  22. 42758.0000\* Shoulder Screw
  23. 42585.1000 Plug, Rear (Package of 10)
  24. 43246.1000 Cover Assy,
  25. 42761.0000\* Screw, Pan Head M4 x 9
  26. 35710.0000 Decal, Warning Hot Liquid
  27. 32591.1000 Tube, Silicone .50" ID x 12.0" (cut to length)
  28. 28526.1000 Tube, Silicone .313" ID x 12.0" (cut to length)
  29. 42912.0000 Foot, Rubber
  30. 43163.0000 Screw, Pan Head #8 x .75"
  31. 42295.0001 Elbow, 90°
  32. 42890.1000 Base Cover
  33. 45457.0000\* Decal, Do not Submerge
  34. 39043.0002\* Decal, Do not Spray
  35. 39043.0001\* Decal, Do not Submerge Server
  36. 35071.0000 Decal, Black Wrap 1.5 Gal. (Not Illustrated)
  37. 37974.0000 Decal, Black Wrap 1.0 Gal. (Not Illustrated)
  38. 35301.0001 Brush, Cleaning (Not Illustrated)
- \* Components of item 19

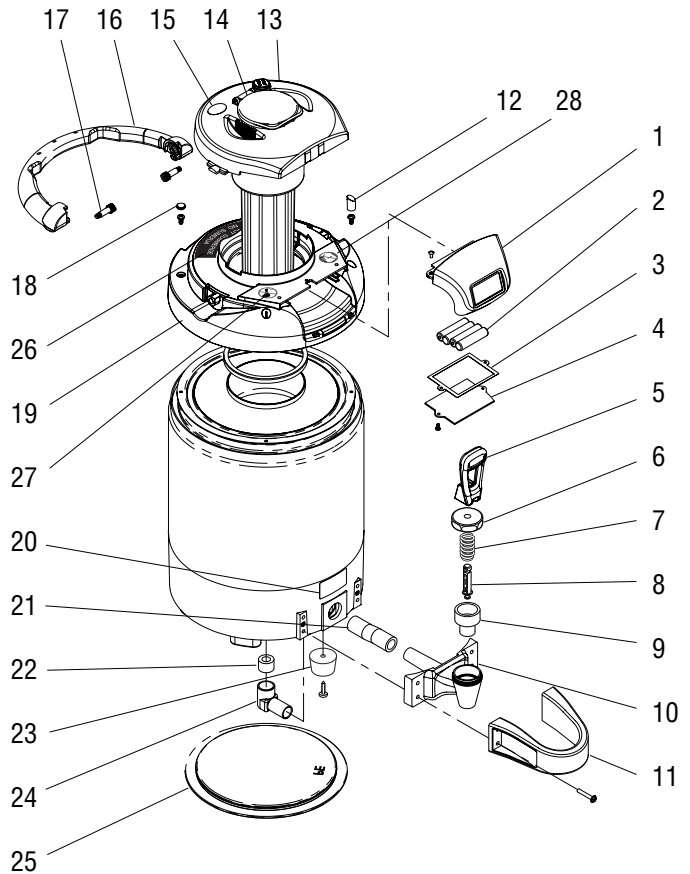

# STAND FOR SERVERS WITHOUT STAND

## REPLACEMENT PARTS

- 39795.0003 Stand, Assy (Includes items 1 - 8)
- 1. 39449.0005 Bracket, Rear
- 2. 39448.0003 Bracket, Front
- 3. 38929.0002 Stand, Server
- 4. 00970.0000 Nut, Keps #8-32
- 5. 38930.0002 Base Plate, Stand
- 6. 44010.0000 Screw, Pan Head #8 x .50"
- 7. 39443.1003 Pad, Adhesive Back .75" Dia.
- 8. 38932.0000 Cover, Drip Tray
- 9. 38931.1002 Kit, Drip Tray (Includes item 7)

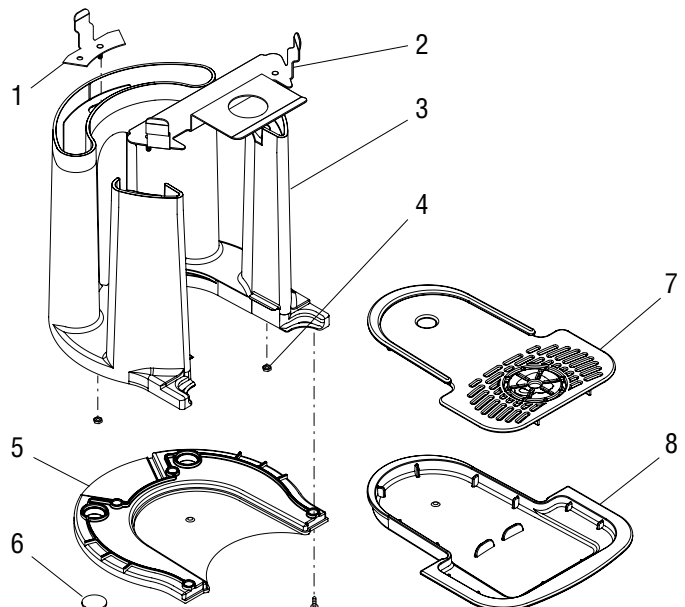

## DIGITAL DISPLAY

The Digital ThermoFresh Server is equipped with a digital probe and display called a Digital Sight Gauge. The probe contains a circuit board designed to sense liquid levels & hold times. During the monitoring process, the probe sends information to the display. The display then allows the user to monitor the liquid level and freshness (hold time) of the beverage held in the server.

### HORIZONTAL BAR

Using the Digital Sight Gauge display, the liquid level in the server can be monitored by watching the horizontal bars. The 1.0 gallon display is equipped with 4 bars and the 1.5 gallon with 6 bars to represent the level inside the dispenser. (each bar represents a quart, or one quarter of a gallon)

All four/six bars will be displayed when the server is full. When the level of the liquid drops to a certain level, the highest bar on the display will no longer be illuminated. These bars will continue to disappear as the level inside the dispenser drops. (See Fig. 1)

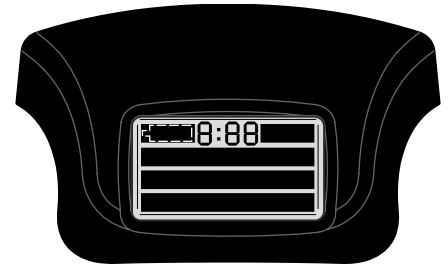

FIG. 1

### COUNTDOWN TIMER

The Digital display is set to count down 2:00 hours. The display counts down in one minute increments, flashing at 15 minutes and continuing to flash once it reaches 0. (See Fig. 1)

### TIMER RESET

The display will reset to 0 when any of the following occurs:

- The liquid level in the server is increased by 1 bar for a sustained period of time. (brewing into, or adding additional liquid to existing beverage)
- A fresh new beverage is brewed into the server.
- When the contact pins of the sensor assembly are disengaged from the display for more than 20 seconds.

### DISPLAY OFF

When the sensor assembly on the server is removed or loosened for more than 20 seconds, the display on the Digital Sight Gauge breaks contact with the pins on the surface of the server. When this happens, the outline that surrounds the Horizontal Level Bars will flash on and off and the time disappears. This indicates that the display has been disengaged from the probe and cannot receive data.

When the display is in place and engaged, but the server is empty, the outline surrounding the Horizontal Level Bars will be on but not flashing and the Freshness Time will be at 0 and flashing. All other portions of the display will not be visible. This indicates the display is engaged and ready to receive data from the probe, but the server is empty.

The only time the display will be completely blank, is when the batteries have been removed or have expired. (See the "Battery Replacement" section for additional information.)

### FRESHNESS TIME

This unit is factory set to count down to 15 minutes, and begin flashing. If a reset condition has not occurred, it will continue to flash and count down to 0.

### LOW BATTERY INDICATOR

When the batteries in the display unit are running low, the display is also equipped with a battery icon. The upper most bar used in monitoring liquid levels, will begin to flash in the shape of a battery to indicate that it is time to replace the batteries. (See FIG. 1)

## BATTERY REPLACEMENT

The Digital Sight Gauge display comes equipped with 4 AAA batteries. The batteries have a use life of approximately 1 1/2 years under normal operating conditions.

**NOTE:** Batteries are not covered under product warranty.

### To replace the batteries:

1. Remove the sensor assembly from the server.
2. Remove the two thumb screws and slide display assembly from the server.
3. Loosen the two screws on the bottom of the display, Fig 2 and rotate the cover approximately 180°.
4. Replace used batteries with 4 AAA alkaline batteries.

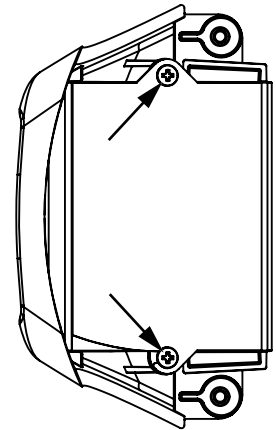
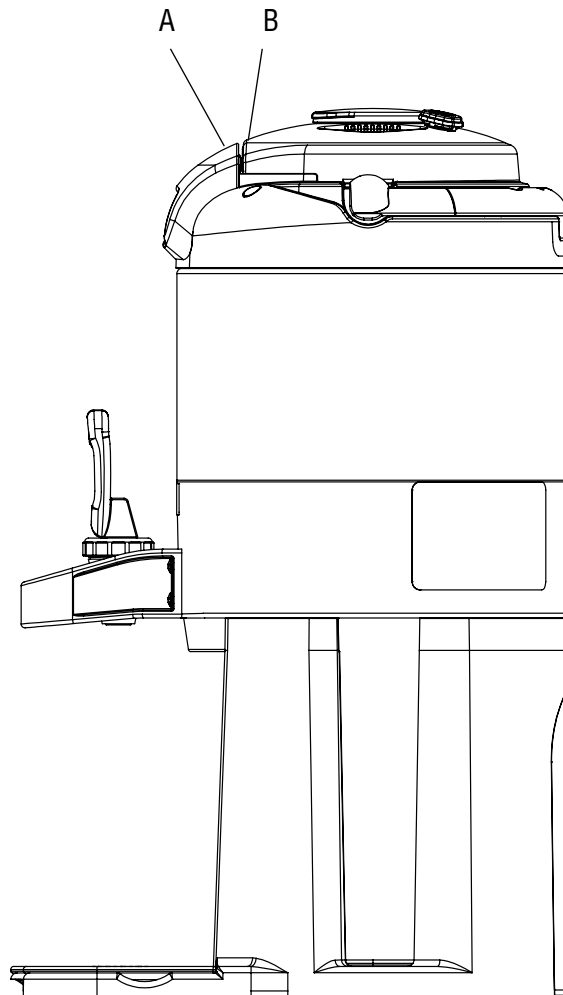

FIG. 2

## SENSOR ASSEMBLY INSTALLATION

Proper installation of the sensor assembly is achieved by aligning the contacts of the sensor assembly (B) with the contacts on the back of the sight gauge (A) when the sever handle is in the fully open position. Once the sensor assembly is engaged into the server, it is locked in place by flipping the handle over approximately 180° as shown in Fig 3.



P4164

FIG. 3

## **BUNN-O-MATIC COMMERCIAL PRODUCT WARRANTY**

Bunn-O-Matic Corp. ("BUNN") warrants equipment manufactured by it as follows:

- 1) Airpots, thermal carafes, decanters, GPR servers, iced tea/coffee dispensers, MCP/MCA pod brewers thermal servers and Thermofresh servers (mechanical and digital)- 1 year parts and 1 year labor.
- 2) All other equipment - 2 years parts and 1 year labor plus added warranties as specified below:
  - a) Electronic circuit and/or control boards - parts and labor for 3 years.
  - b) Compressors on refrigeration equipment - 5 years parts and 1 year labor.
  - c) Grinding burrs on coffee grinding equipment to grind coffee to meet original factory screen sieve analysis - parts and labor for 4 years or 40,000 pounds of coffee, whichever comes first.

These warranty periods run from the date of installation BUNN warrants that the equipment manufactured by it will be commercially free of defects in material and workmanship existing at the time of manufacture and appearing within the applicable warranty period. This warranty does not apply to any equipment, component or part that was not manufactured by BUNN or that, in BUNN's judgment, has been affected by misuse, neglect, alteration, improper installation or operation, improper maintenance or repair, non periodic cleaning and descaling, equipment failures related to poor water quality, damage or casualty. In addition, the warranty does not apply to replacement of items subject to normal use including but not limited to user replaceable parts such as seals and gaskets. This warranty is conditioned on the Buyer 1) giving BUNN prompt notice of any claim to be made under this warranty by telephone at (217) 529-6601 or by writing to Post Office Box 3227, Springfield, Illinois 62708-3227; 2) if requested by BUNN, shipping the defective equipment prepaid to an authorized BUNN service location; and 3) receiving prior authorization from BUNN that the defective equipment is under warranty. **THE FOREGOING WARRANTY IS EXCLUSIVE AND IS IN LIEU OF ANY OTHER WARRANTY, WRITTEN OR ORAL, EXPRESS OR IMPLIED, INCLUDING, BUT NOT LIMITED TO, ANY IMPLIED WARRANTY OF EITHER MERCHANTABILITY OR FITNESS FOR A PARTICULAR PURPOSE.** The agents, dealers or employees of BUNN are not authorized to make modifications to this warranty or to make additional warranties that are binding on BUNN. Accordingly, statements by such individuals, whether oral or written, do not constitute warranties and should not be relied upon.

If BUNN determines in its sole discretion that the equipment does not conform to the warranty, BUNN, at its exclusive option while the equipment is under warranty, shall either 1) provide at no charge replacement parts and/or labor (during the applicable parts and labor warranty periods specified above) to repair the defective components, provided that this repair is done by a BUNN Authorized Service Representative; or 2) shall replace the equipment or refund the purchase price for the equipment.

**THE BUYER'S REMEDY AGAINST BUNN FOR THE BREACH OF ANY OBLIGATION ARISING OUT OF THE SALE OF THIS EQUIPMENT, WHETHER DERIVED FROM WARRANTY OR OTHERWISE, SHALL BE LIMITED, AT BUNN'S SOLE OPTION AS SPECIFIED HEREIN, TO REPAIR, REPLACEMENT OR REFUND.**

In no event shall BUNN be liable for any other damage or loss, including, but not limited to, lost profits, lost sales, loss of use of equipment, claims of Buyer's customers, cost of capital, cost of down time, cost of substitute equipment, facilities or services, or any other special, incidental or consequential damages.

392, AutoPOD, AXIOM, BrewLOGIC, BrewMETER, Brew Better Not Bitter, BrewWISE, BrewWIZARD, BUNN Espresso, BUNN Family Gourmet, BUNN Gourmet, BUNN Pour-O-Matic, BUNN, BUNN with the stylized red line, BUNNlink, Bunn-OMatic, Bunn-O-Matic, BUNNserve, BUNNSERVE with the stylized wrench design, Cool Froth, DBC, Dr. Brew stylized Dr. design, Dual, Easy Pour, EasyClear, EasyGard, FlavorGard, Gourmet Ice, Gourmet Juice, High Intensity, iMIX, Infusion Series, Intellisteam, My Café, Phase Brew, PowerLogic, Quality Beverage Equipment Worldwide, Respect Earth, Respect Earth with the stylized leaf and coffee cherry design, Safety-Fresh, savemycoffee.com, Scale-Pro, Silver Series, Single, Smart Funnel, Smart Hopper, SmartWAVE, Soft Heat, SplashGard, The Mark of Quality in Beverage Equipment Worldwide, ThermoFresh, Titan, trifecta, Velocity Brew, A Partner You Can Count On, Air Brew, Air Infusion, Beverage Bar Creator, Beverage Profit Calculator, Brew better, not bitter., BUNNSource, Coffee At Its Best, Cyclonic Heating System, Daypart, Digital Brewer Control, Nothing Brews Like a BUNN, Pouring Profits, Signature Series, Tea At Its Best, The Horizontal Red Line, Ultra are either trademarks or registered trademarks of Bunn-O-Matic Corporation.